

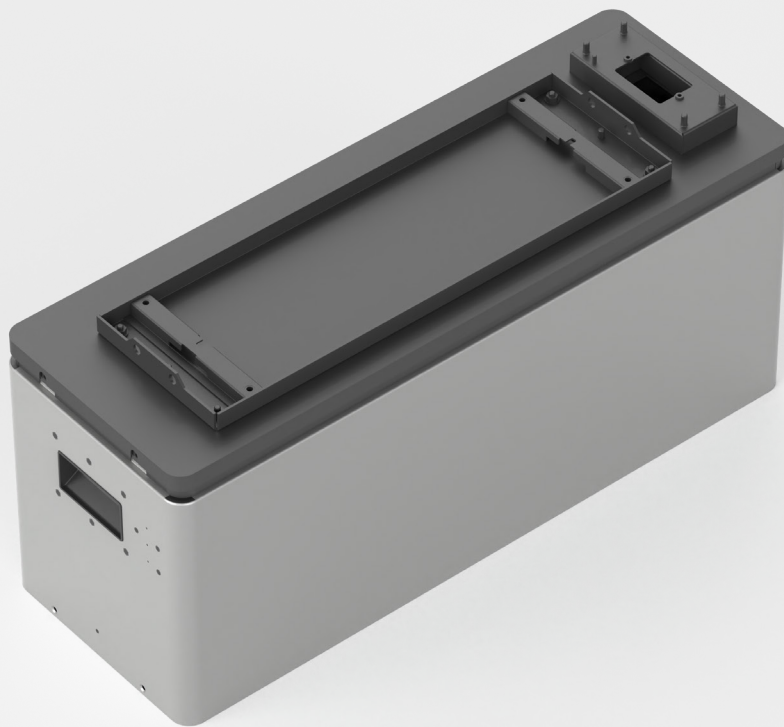

Sunsynk Elite 5.1kWh Battery IP65



USER MANUAL

SS-5.1kWh-ELITE-BATT-1P-IP65-00

www.sunsynk.com
sales@sunsynk.com
customerservices@sunsynk.com

About this Document

This manual provides instructions for safe installation, operation, and maintenance of the Sunsynk Elite 5.1kWh BATT IP65 battery. Please read it carefully before installation and follow all steps during the process. If anything is unclear, contact Sunsynk for guidance and clarification. Contents may be periodically updated or revised due to product development. The information in this manual is subject to change without notice.

All Rights Reserved

No part of this document can be reproduced in any form or by any means without the formal permission of Sunsynk.

Intended Audience

This document is intended for use by:

- Qualified Personnel / Installers
- End-users

Intended Use

The battery is designed for energy storage applications in residential and commercial solar PV systems, backup power systems, and hybrid systems.

Disclaimer

Sunsynk is not responsible for any damage or consequences resulting from:

- Damage occurring during transportation by the customer.
- Storage conditions that do not meet the requirements outlined in this manual.
- Improper storage, installation, or use of the battery.
- Installation or operation by unqualified personnel.
- Failure to follow the operation instructions and safety precautions in this manual.
- Use in extreme environments not covered in this manual.
- Operation beyond the specified voltage, current, temperature, or other limits.
- Unauthorized modifications to the product, software, or removal of components.
- Damage caused by force majeure events (e.g., earthquake, fire, storm).
- Expired warranty or failure to extend warranty coverage.
- Installation or use in environments not compliant with relevant international standard.

Manufacturer & Global Support Contact Information



South Africa

Mon - Fri
9am - 5pm

+27 10 100 3589



United Kingdom

Mon - Fri
9am - 5pm

+44 151 832 4300



Netherlands

Mon - Fri
9am - 5pm

+31 40 798 7497



Hong Kong

Mon - Fri
9am - 5pm

+852 3704 4979



Australia

Mon - Fri
9am - 5pm

+61 7 3155 5555



Spain

Mon - Fri
9am - 5pm

+37 822 112 079



USA

Mon - Fri
9am - 5pm

+1 813 723 2225

TABLE OF CONTENTS

INTRODUCTION	4	COMMISSIONING	27
Applications	4		
Key Advantages	4	OPERATION	28
Compliance and Standards	4	Start the Battery System	28
User Guidance	4	Stop the Battery System	29
SAFETY INFORMATION	5	TROUBLESHOOTING	30
Safety Symbols and Definitions	5		
Qualified Personnel	6	MONITORING	31
General Safety	7	Data Logger Installation	31
Electrical Safety	7	Connecting to Wi-Fi	31
Environmental Safety	7	Network Cable	32
Safety Handling	8	Registration	33
Prohibited Uses	8	Requesting User Level Access Change	33
Emergency Procedures	9	Creating a Plant	34
		Adding a Device	36
PRODUCT OVERVIEW	10	Editing a Plant	36
Product Identification Labels	10	Plant Overview	37
Technical Specifications	11	Battery Management	40
Battery Module (Dimensions, Weight & Interface)	13	Event	41
Power Distribute Unit (PDU)	14	INSPECTION, CLEANING AND MAINTENANCE	42
Battery Pack	15	General Information	42
Base	15	Inspection	42
System Components	16	Cleaning	42
Power Distribute Unit Package	16	Maintenance	42
Battery Pack Package	17		
Application Scenario	17	STORAGE	43
INSTALLATION GUIDELINES	18	BATTERY RECOVERY	44
Pre-Installation Inspection	18	Recovery Process and Steps of Cathode Materials	44
Packaging	18	Recovery of Anode Materials	44
Site Requirements	18	Recovery of Diaphragm	44
Handling and Mounting Instructions	18	List of Recycling Equipment	44
Layout	19	ENVIRONMENTAL DISPOSAL	45
Installation Clearance	20		
Installing the Battery	20	TRANSPORTATION REQUIREMENTS	46
Method 1	21		
Method 2	23		
ELECTRICAL CONNECTION	25		
Preparation Before Wiring	25		
Package Contents	25		
Plug Assembly Instruction	25		

INTRODUCTION

Thank you for choosing the Sunsynk Elite 5.1kWh BATT IP65 Lithium Iron Phosphate (LiFePO₄ or LFP) battery. This energy storage system is designed for high-power applications, efficient use in limited installation spaces, and offers an exceptionally long cycle life. It provides safe and reliable power for residential, commercial, and industrial energy systems.

Each module delivers a 5.12 kWh capacity and can be connected in parallel with multiple units to expand the total system capacity and output power. This modular design makes the Elite 5.1kWh highly flexible, allowing system sizes to be scaled according to the energy requirements of the user.

The battery is equipped with a built-in Battery Management System (BMS) that:

- Monitors real-time voltage, current, and temperature.
- Ensures over-charge, over-discharge, over-current, and short-circuit protection.
- Provides cell balancing to maximize performance and extend service life.
- Communicates seamlessly with Sunsynk inverters and other approved compatible systems via CAN/RS485 protocols.

Applications

- Solar PV energy storage.
- Backup power for residential and commercial loads.
- Peak-shaving and load-shifting in commercial and industrial facilities.
- Microgrid and distributed energy storage systems.

Key Advantages

- High safety: Uses LiFePO₄ chemistry with excellent thermal stability.
- Long cycle life: ≥ 6,000 cycles at 90% depth of discharge (DOD).
- Scalable: Parallel connection supports large-capacity energy storage.
- High efficiency: Fast charging and discharging capability with low energy loss.
- Smart monitoring: Integrated BMS with communication interface for inverter and system integration.
- Compact design: Space-saving with flexible installation options.

Compliance and Standards

The Sunsynk Elite 5.1kWh BATT IP65 battery meets international safety and performance standards, ensuring reliable operation and global compatibility. For detailed information, refer to the Technical Specification section of this manual or contact Sunsynk for further assistance.

User Guidance

This manual provides:

- General and electrical safety precautions.
- Installation requirements and wiring instructions.
- Battery operation, communication, and monitoring guidance.
- Maintenance and troubleshooting information.



NOTICE





Please read this manual carefully before installation and operation. Keep it for future reference and ensure that all installers and users are familiar with the safety precautions and instructions provided.

SAFETY INFORMATION













Sunsynk products are engineered with safety as a top priority. However, like all electrical devices, they can pose risks if used incorrectly, including fire or electric shock, which may result in serious injury or death. To ensure your safety, please read and follow all safety precautions carefully before use.









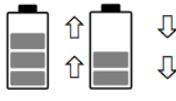

Safety Symbols and Definitions

The following symbols are used in this document and their meanings are provided below.

 DANGER
Indicates an immediate hazard that, if not avoided, will result in serious injury or death. This is the highest level of risk.
 WARNING
Indicates a potential hazard that could result in serious injury or death if not avoided. It is slightly less severe than "DANGER".
 CAUTION
Highlights a potential hazard that could cause minor injuries or property damage if not avoided.
 NOTICE
Provides helpful information that does not indicate any hazard.

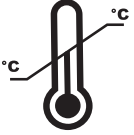
The following safety symbols are used in this document and may also appear on product specification labels and packaging. Their meanings are explained below.

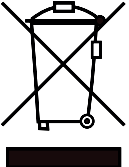
Symbol	Description	Symbol	Description
	This symbol indicates information that if ignored, could result in personal injury, physical damage or even death due to incorrect handling.		This product's batteries contain an explosive, self-reactive material that could blow up when heated.
	Electrical Hazard.		Read the manual.
	Danger.		Indicates that this product is recyclable.
	The Battery is heavy and can cause injury if not handled safely.		Do not place near open fire or incinerate. Do not use near heaters or hot temperature sources.
	Do not submerge the battery in water or expose it to moisture or liquid.		Do not disassemble or alter the battery in any way. Do not strike or puncture the battery.
	Do not drop, deform, or impact the battery.		Do not step or put any objects onto the battery.



Symbol	Description	Symbol	Description
	Keep out of reach of children, animals, and insects.		Li-ion Battery.
	Rechargeable.		Charging and Discharging.
	Direct Current.		Product exposure.
			Recommended Charge Instructions.
	Follow the indicated temperatures.		BATTERY INPUT Battery Discharge Voltage, Battery Discharge Current, Input Voltage Type, Battery Discharge Power.
	Contact the supplier within 24 hours if there is anything wrong. In case of leakage contact with eyes or skin, immediately clean with water and seek help from a doctor.		Do not dispose the device, accessories, and packaging with regular waste. Follow local ordinances or contact the manufacturer for disposal guidance.
	The UKCA marking is used for products placed on the market in Great Britain (England, Scotland and Wales). The UKCA marking applies to most products for which the CE marking could be used.		CE mark is attached to the solar inverter to verify that the unit follows the provisions of the European Low Voltage and EMC Directives.



CAUTION!
Do not plug or unplug the power cables when the T-BAT System is on, doing so could result in an arc discharge which could cause serious harm!

CAUTION!
Ground connection is mandatory!

WARNING!
Handle with care: No external force allows on BMS slot.

Qualified Personnel

The Sunsynk Elite 5.1kWh BATT IP65 Lithium Iron Phosphate (LiFePO₄ or LFP) battery must only be installed, commissioned, operated, and maintained by qualified personnel.

Qualified personnel are individuals who:

- Have received formal training in electrical systems and photovoltaic (PV) installations.
- Are familiar with local and national electrical codes, regulations, and safety standards.
- Understand the risks involved when working with both low- and high-voltage equipment.
- Possess the skills to correctly use the required tools, personal protective equipment (PPE), and test instruments.

For safe and reliable installation, Sunsynk strongly recommends using a Sunsynk-approved installer. These installers are trained specifically on Sunsynk products and are equipped with the knowledge to ensure correct installation, commissioning, and long-term operation.



NOTICE

- Installation or operation by unqualified personnel may cause personal injury, electric shock, fire hazards, or property damage.
- Any damage or failure resulting from improper installation, unauthorized modifications, or neglect of instructions will void the product warranty.
- Always follow all safety warnings, handling instructions, and manufacturer recommendations when working with the battery.

General Safety

- Use the battery only as instructed in this manual.
- Do not use the battery if it appears broken, damaged, or compromised in any way.
- The battery is non-user-serviceable, do not attempt to open or repair it.
- Handle the battery with care during installation, transportation, or relocation.
- Do not connect the Sunsynk Elite 5.1kWh BATT IP65 battery with batteries of a different type or model unless otherwise specified the battery may be paired only with a compatible battery.
- Do not operate the battery with faulty or incompatible inverters.
- Always contact the supplier within 24 hours if any abnormal condition occurs.
- After unpacking, carefully check the product and packing list. If any parts are missing or damaged, contact your retailer immediately.
- Recharge within 48 hours after full discharge.
- Charge the battery at least every 6 months; keep State of Charge (SOC) between 40%-60% during long-term storage.
- Warranty does not cover damage caused by misuse or violation of the above precautions.

Electrical Safety

- Before installation, disconnect the grid power supply and ensure the battery is switched off.
- Verify correct wiring: do not reverse positive (+) and negative (-) cables, and ensure no short circuit with external devices.
- Never connect the battery directly to PV solar panel wiring.
- Do not connect the battery directly to AC power.
- Ensure the battery system is properly grounded with a resistance of less than 1Ω.
- Confirm that the electrical parameters of the battery system match the connected equipment.
- Disconnect all terminals before maintenance.
- Always cut off the power supply and fully shut down the battery before moving or performing any repairs.

Environmental Safety

To ensure safe operation and long service life, the Sunsynk Elite 5.1kWh BATT IP65 Lithium Iron Phosphate (LiFePO₄ or LFP) battery must be installed in an environment that meets the following conditions:

LOCATION AND PROTECTION

- Install indoors or in a sheltered environment, protected from direct sunlight, rain, dust, and condensation.
- Keep away from flammable materials, corrosive substances, or explosive gases.
- Ensure adequate physical protection against accidental impact or mechanical damage.

VENTILATION AND CLEARANCE

- Provide sufficient airflow around the battery to prevent heat build-up.
- Maintain at least 60 cm clearance at the front and top, and 30 cm at the sides for cooling and maintenance access.
- Do not block air vents or enclose the battery in an airtight cabinet.

PROHIBITED AREAS

- Do not install outdoors without appropriate weatherproof enclosures.
- Do not install in bedrooms, living spaces, or occupied areas where noise or heat may cause discomfort.
- Avoid areas exposed to salt spray, chemicals, or corrosive vapors (e.g., near swimming pools or industrial sites).

Safety Handling

To ensure safe operation and longevity of the Sunsynk Elite 5.1kWh BATT IP65 Lithium Iron Phosphate (LiFePO₄ or LFP) battery, the following precautions must be observed:

- Cables: Keep all cables protected from damage. Do not bend, crush, or expose them to heat or moisture.
- Foreign Objects: Never insert objects into the battery or its connectors.
- Cleaning: Do not use solvents, chemicals, or cleaners on the battery. If cleaning is required, use a dry, soft cloth only.
- Flammable Materials: Do not expose the battery to fire, heat sources, or flammable/harsh chemicals.
- Painting/Modifications: Do not paint, disassemble, modify, or tamper with the battery.
- Servicing: Only Sunsynk staff or authorized service personnel may open, repair, or service the battery. Unauthorized handling or repair will void the warranty and may result in hazards.
- Fire Safety: In case of fire, use a dry powder fire extinguisher only. Do not use water or liquid extinguishers.
- Environment: Keep the battery away from water, excessive dust, vibration, and direct sunlight. Do not expose to freezing temperatures or high humidity.
- Handling: Always lift the battery with proper equipment or sufficient manpower. Avoid dropping or subjecting it to impact.
- Storage/Transport: Store and transport the battery in an upright position, in a clean, dry, and ventilated environment.



WARNING

Improper handling may cause injury, fire, electric shock, or permanent damage to the battery.

Prohibited Uses

To prevent hazards, never:

- Short-circuit the battery terminals or connect them directly with metal objects.
- Immerse the battery in water or allow it to get wet.
- Connect incompatible chargers, inverters, or third-party devices not approved by Sunsynk.
- Operate the battery outside its rated voltage, current, or temperature limits.
- Install the battery in a sealed or poorly ventilated area.
- Place heavy objects on top of the battery.
- Use the battery if it is physically damaged, leaking, or emits unusual odors or sounds.



WARNING

Improper handling or prohibited use may lead to electric shock, fire, property damage, or personal injury, and will void the product warranty.

Emergency Procedures

In case of accidental exposure to battery materials, take immediate action as outlined below. Always seek medical assistance after providing first aid.

- Do not use a damaged battery.
- Return it to Sunsynk or dispose it properly at a certified recycling facility.
- Leaking electrolytes can cause skin irritation, chemical burns, or other serious injuries.
- Avoid all direct contact with leaking material.

Hazard	Action
Eyes	Flush eyes with plenty of clean water for at least 15 minutes, lifting eyelids occasionally. Seek immediate medical attention.
Skin	Remove contaminated clothing. Rinse skin thoroughly with water or shower for at least 15 minutes. Seek medical attention.
Inhalation	Move the affected person to fresh air immediately. If breathing is difficult, provide oxygen if available. Seek medical assistance.
Ingestion	Do not induce vomiting. Do not give anything by mouth if the person is unconscious. If conscious, rinse mouth with water and give small sips of water or milk. Call a physician or poison control centre immediately.



WARNING

Failure to follow the safety instructions in this manual may result in serious injury, electric shock, fire, or damage to the battery and will void the warranty.



NOTICE

Always use the battery as instructed in this manual. Safe handling and proper maintenance will ensure reliable performance and extend the service life of your battery.

PRODUCT OVERVIEW







The Product Overview provides key information about the Sunsynk Elite 5.1kWh BATT IP65 battery system, helping users understand its components, specifications, and applications.

Product Identification Labels

The battery is equipped with identification and rating labels that display critical information, including model number, serial number, voltage, capacity, safety certifications, and manufacturer details. These labels should be referenced during installation, maintenance, and troubleshooting to ensure proper use and maintain warranty coverage. The Rating Label below is affixed to the side of the battery module.

225

SS-5.1kWh-ELITE-BATT-1P-IP65-00
IFpP52/161/120[16S]M/-20+50/90

	① 100 Ah	② 5.12 kWh	③ 100 A _{max}	
	④ 51.2 V _{DC}	⑤ 44.8 V _{DCmin}	⑥ 57.6 V _{DCmax}	
	⑦ 0°C _{min} ⑦ +55°C _{max}	⑧ -20°C _{min} ⑧ +55°C _{max}	⑨ 0°C _{min} ⑨ +35°C _{max}	
	LiFePO ₄ (LFP)		⑩ IP65	



UK
CA
CE

IEC 62619
UN38.3

SN: XXXXXXXXXXXXXXXXXXXX

www.sunsynk.com

Item	Requirement	SS-5.1kWh-ELITE-BATT-1P-IP65-00
1	Rated Capacity	100 Ah
2	Battery Usable Energy	5.12 kWh
3	Max. Charge & Discharge Current	100 A
4	Rated Voltage	51.2 Vdc
5	Min. Operating Voltage	44.8 Vdc
6	Max. Operating Voltage	57.6 Vdc
7	Min./Max. Charge Temperature	0 °C / 55 °C
8	Min./Max. Discharge Temperature	-20 °C / 55 °C
9	Min./Max. Storage Temperature	0 °C / 35 °C
10	Ingress Protection Rating	IP65 (after stacking)

Technical Specifications

The technical data below summarizes the electrical, mechanical, and operational parameters of the battery, providing installers and system designers with the information needed to integrate the battery safely and efficiently into energy systems.

SS-5.1kWh-ELITE-BATT-1P-IP65-00				
Model	Battery Module Capacity (Ah)	Battery Module Quantity	Energy (kWh)	Usable Energy (kWh) ^[1]
SS-5.1KWh-ELITE	100	1	5.12	5.12
SS-10.2KWh-ELITE	200	2	10.24	10.24
SS-15.3KWh-ELITE	300	3	15.36	15.36
SS-20.4KWh-ELITE	400	4	20.48	20.48
SS-25.6KWh-ELITE	500	5	25.6	25.6
SS-30.7KWh-ELITE	600	6	30.72	30.72

Main Parameter		
Battery Chemistry	Lithium Iron Phosphate (LifePO4 or LFP)	
Battery Module Energy	5.12 kWh	
Battery Module Voltage	51.2 V	
Nominal Voltage	51.2 V	
Operating Voltage	44.8~57.6 V	
Scalability	Max. 6 modules per Cluster (PDU); Multiple clusters supported	
Charge/Discharge Current	Max. ^[2]	1PDU + 1pack: 100A; 1PDU + 2pack: 200A; 1PDU + 3pack: 250A; 1PDU + 4pack: 250A; 1PDU + 5pack: 250A; (1 PDU is compatible with at least 1 battery and at most 6 batteries)
	Peak (10s,25°C)	1PDU + 1pack: 150A; 1PDU + 2pack: 270A; 1PDU + 3pack: 360A; 1PDU + 4pack: 360A; 1PDU + 5pack: 360A; (1 PDU is compatible with at least 1 battery and at most 6 batteries)

Other Parameter

Recommend Depth of Discharge	90%
System Dimension (WxDxH mm)	720*600*(307+283*m[3])
System Weight (kg)	53*m+25
Master LED Indicator	Battery Module: 3 LED (working, alarming, protecting)
	PDU Module: 5 LED (SOC:20%~100%) & 2 LED (working, alarming)
IP Rating of Enclosure	IP65 (after stacking)
Working Temperature	Charge: 0°C~+55°C ^[3] Discharge: -20°C~+55°C
Storage Temperature	0°C ~ +35°C
Humidity	5% ~ 95%
Altitude	≤3000m
Cycle Life ^[4]	≥6000 (25±2°C, 90%DOD, 0.5C/0.5C, 70%EOL)
Installation	Floor-Mounted
Communication Port	CAN2.0, RS485
Life Cycle Power During Warranty Period ^[5]	16MWh@70%EOL
Certification	This product complies with ISO and its relevant norms and standards. Approvals and certifications are subject to change without notice. Please verify current status with Sunsynk before ordering.
Warranty	See website for Warranty details
Manufacturer Country	China

^[1] DC Usable Energy, test conditions: 90% DOD, 0.5C charge & discharge at 25° C. System usable energy may vary due to system configuration parameters.

^[2] The current is affected by temperature and SOC.

^[3] With optional heating film activated, Charge temperature range is -20°C ~ +55°C.

^[4] The cycle life specification of ≥6000 cycles refers to laboratory test performance under controlled conditions.

^[5] The warranty is due whichever reached first of warranty period or energy throughout. The stated 16 MWh throughput represents the warranted limit for product performance and warranty enforcement.

m: the number of battery packs in per cluster, $1 \leq m \leq 6$.

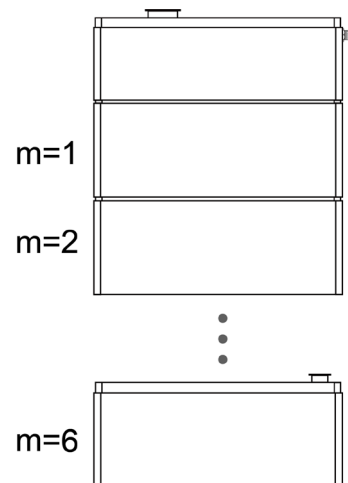

Battery Module (Dimensions, Weight & Interface)

This section details and displays the module's size, weight, mounting options, and design features for safe, space-efficient installation. It also outlines the available connections and ports, including terminals and communication interfaces, for proper integration with other system components.

- The Sunsynk Elite 5.1kWh battery module Dimensions and Weight are presented below:

Component	Width	Depth	Height	Weight
Battery Module	720 mm	255 mm	300 mm	53 kg
PDU3 (Control Unit)	720 mm	255 mm	228 mm	18.5 kg
Base	720 mm	255 mm	68 mm	6.5 kg

- The Sunsynk Elite 5.1kWh battery module is equipped with a user-friendly interface that provides all necessary electrical and communication connections for safe integration into energy systems.

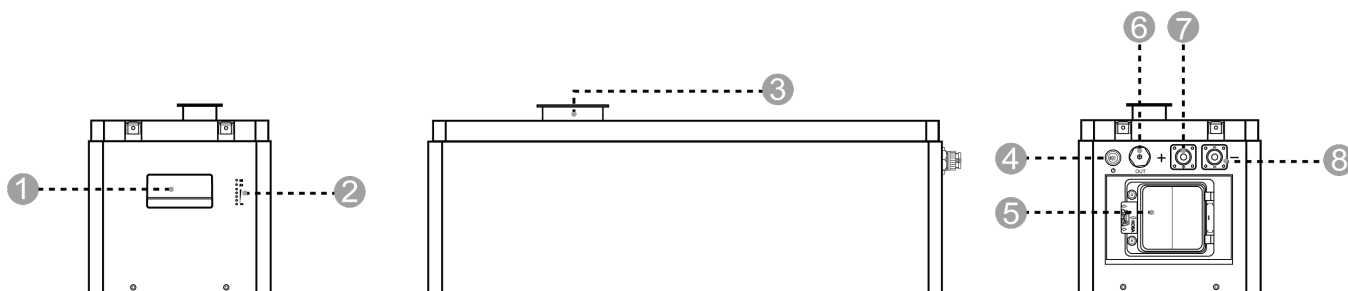

Items	
1. Handle	5. PDU Circuit Breaker
2. Status Indicator	6. Parallel Communication Port OUT
3. PDU Module Dock Terminals	7. Positive Battery Output Port
4. BMS switch	8. Negative Battery Output Port

Interface	Description and Instructions
OUT port	Parallel communication terminal: (RJ45 port) To connect the "IN" terminal of next battery for communication between multiple parallel batteries.
Handle	To help carry the battery.
PDU Circuit Breaker	To start or stop the PDU.
Status Indicator	Indicating the operating status of the entire battery system, include SOC, RUN, ALARM, and ERROR. Refer to introduction in the section Power Distribute Unit (PDU).

Power Distribute Unit (PDU)

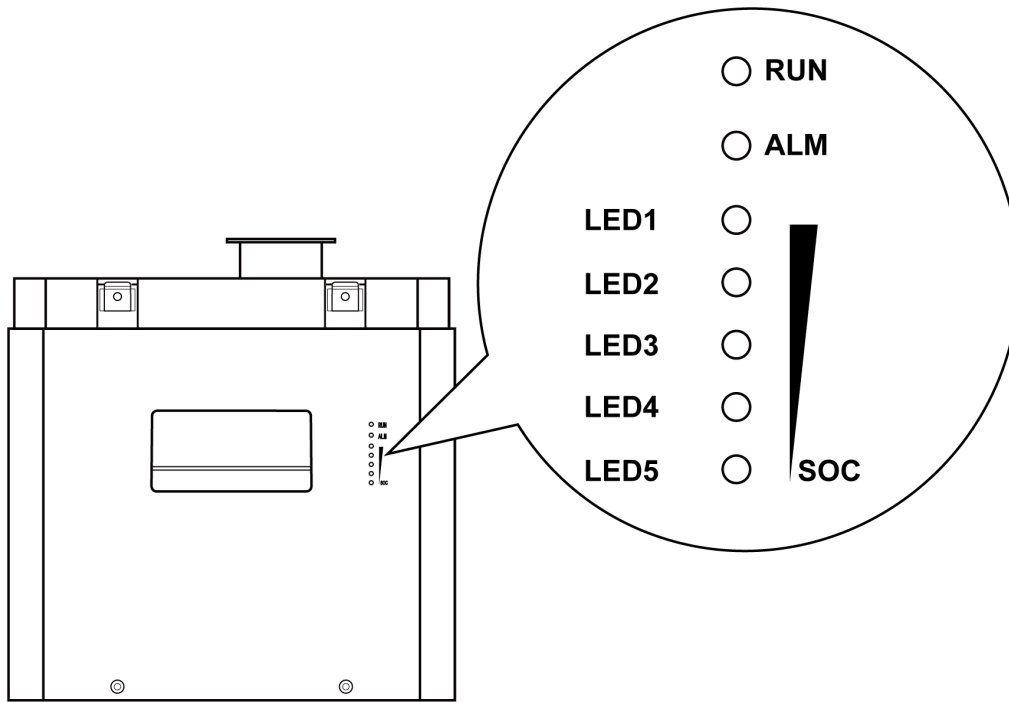

Interface	Description and Instructions
RUN LED	Green, keep flashing when power switch is on.
ALARM LED	Red, long bright if battery is protected.
SOC LED	5 blue LEDs, battery capacity indicator, each light represents 20% capacity.

The following table presents the Led indication definition:

Condition	RUN	ALARM	Error	LED 1	LED 2	LED 3	LED 4	LED 5
Power off	Off							
Charge	Blink	●	Off	●				
Discharge or Idle		Blink if Alarm Exists	Off	●				
Alarm		Blink	Off	●				
System error/ Protect		Off	●	Other LEDs are same as above.				
Upgrade	Blink Fast							
Critical Error	Blink Slow							

Battery Pack

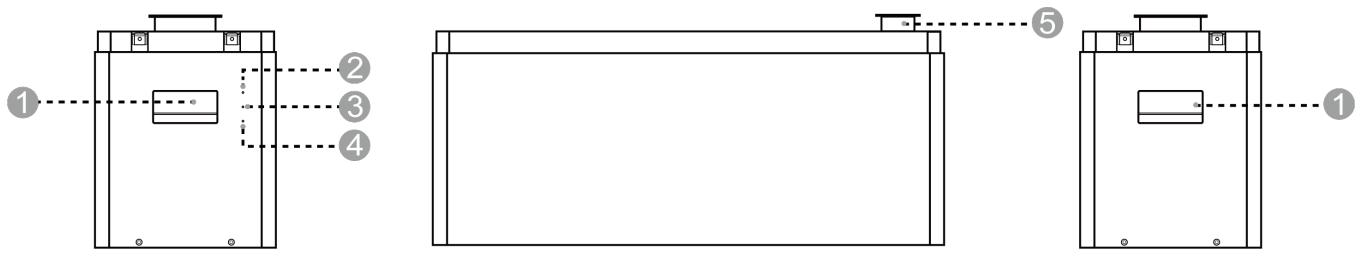

Items	
1. Handle	4. ERROR LED
2. RUN LED	5. Battery Module Dock Terminals
3. ALARM LED	

Interface	Description and Instructions
RUN LED	Green, keep flashing when the power switch is on.
ALARM LED	Yellow, flashes when the battery is in alarm.
ERROR LED	Red, long bright if battery is protected.
Handle	To help carry the battery

Base

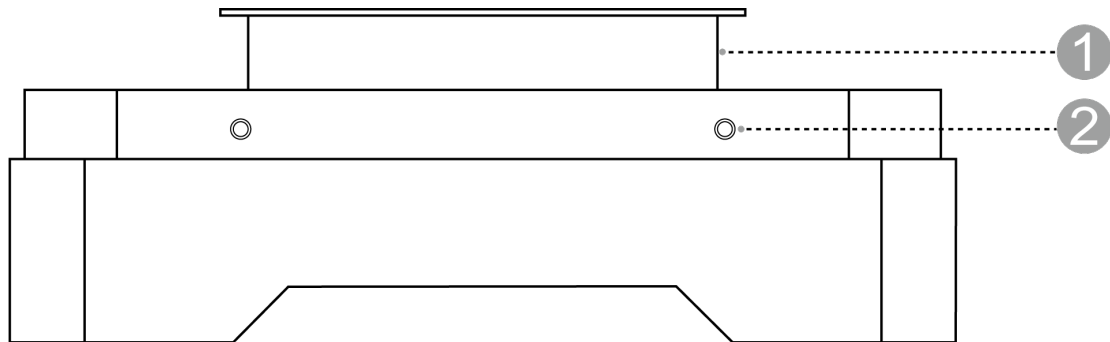



Items	
1. Module Dock Terminals	2. Screw Hole

System Components

System components introduces the main hardware elements, including the battery module, PDU, connectors, and interfaces, to give a clear understanding of the system structure.

Check if you received all the items listed below. Ensure that nothing is damaged in the package.

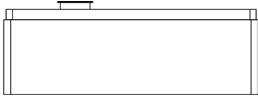
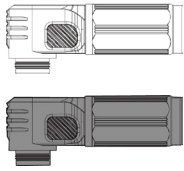
Power Distribute Unit Package

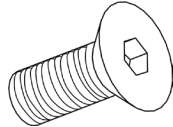
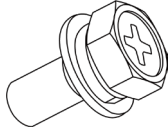
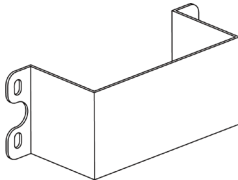
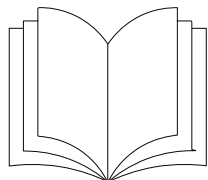
 <p>PDU x1</p>	 <p>1500mm RJ45 Communication Cable x1</p>	 <p>600mm Ground Cable x1</p>	 <p>Terminal x2</p>
 <p>Fixed Support x2 (Thickness: 2.5mm)</p>	 <p>Bolt x2 (M4x10)</p>	 <p>Bolt x2 (M8x40)</p>	 <p>Washer x2</p>
 <p>Adjusting Block x4</p>	 <p>Base x1</p>	 <p>Screw x4 (M4x8)</p>	 <p>Bolt x1 (M4x12)</p>
 <p>Anti-Tamper Bracket x1</p>	 <p>Bolt x4 (M4x10)</p>	 <p>Pamphlet x1</p>	

Battery Pack Package

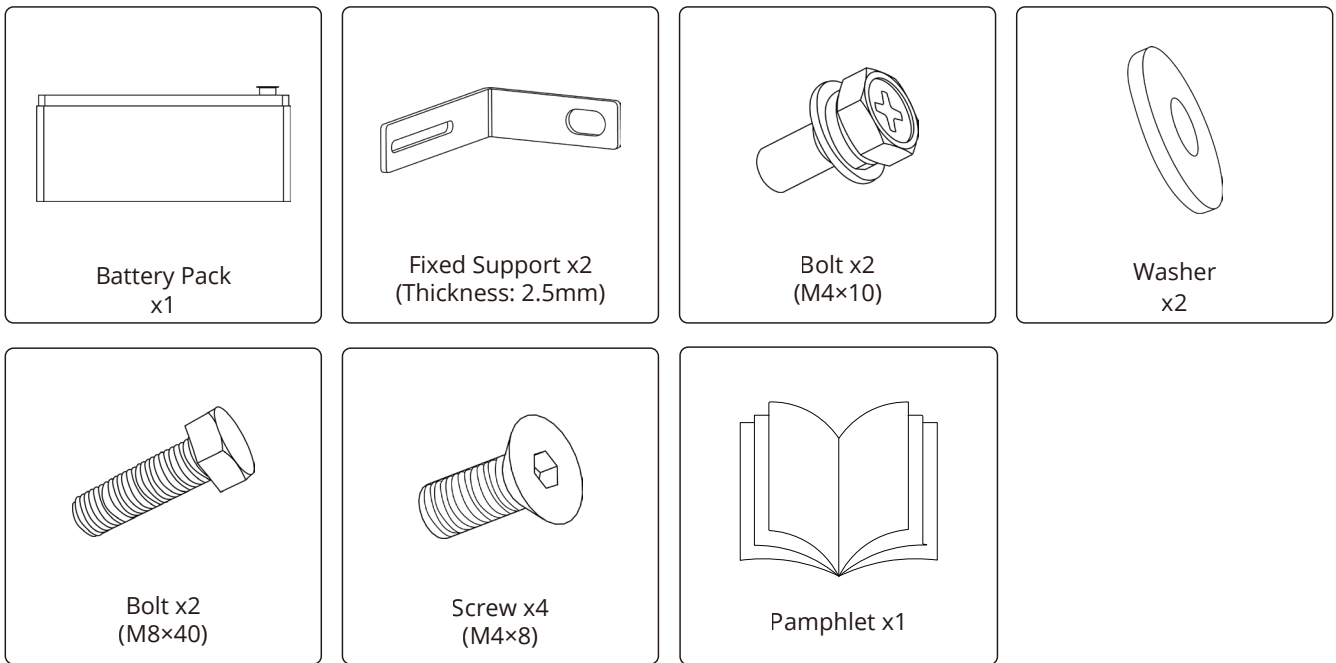

Application Scenario

The illustration below shows typical applications of this battery, including residential solar storage, backup power, and hybrid energy systems. These examples highlight the battery's flexibility and scalability. For other system designs, please consult your system integrator to ensure the best solution for your requirements.

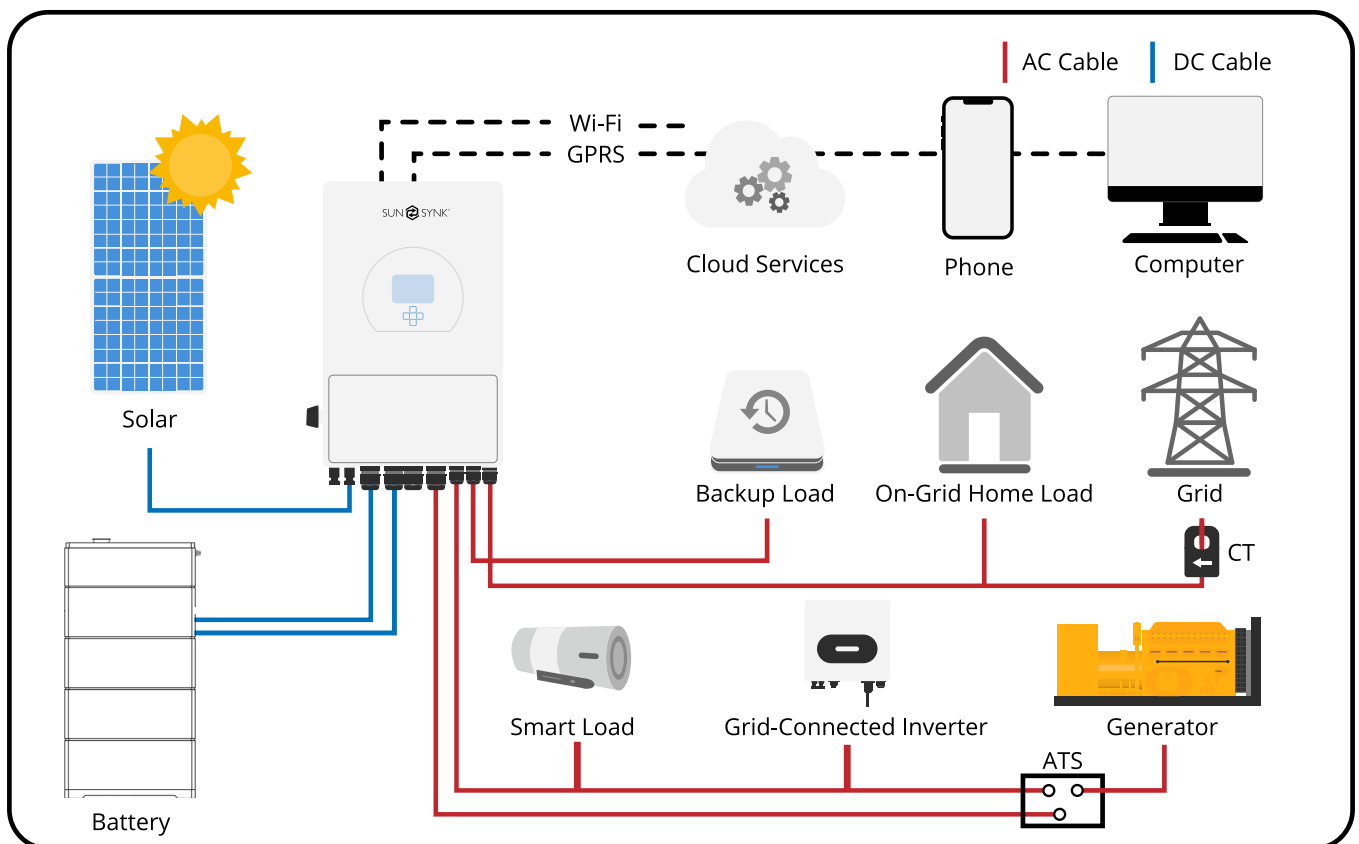

INSTALLATION GUIDELINES

Pre-Installation Inspection

Packaging

Before installing the battery, carry out the following checks:

- Inspect the battery and packaging for any signs of shipping damage.
- Verify that all parts and accessories are present.
- Check the battery enclosure for swelling, deformation, or abnormalities.



NOTICE

Do not install or use the battery if any issues are found. Contact your supplier or installer immediately.

Site Requirements

- The Sunsynk Elite 5.1kWh BATT IP65 Lithium Iron Phosphate battery is rated IP65, this ensures complete protection against dust and solid particles. It is resistant to low-pressure water jets from any direction, with no harmful effects.
- **Note:** IP65 does not make the battery waterproof, therefore it must be installed in locations where it is not continuously exposed to rain or water.
- Select a dry, clean, and well-ventilated location, away from direct sunlight, rain, snow, heat sources, cold air outlets, and flammable materials.
- Maintain at least 60 cm clearance at the front and top, and 30 cm at the sides for airflow and heat dissipation.
- Do not install in environments with excessive oil, smoke, steam, dust, moisture, or at altitudes above 3000 m.
- Near coastal areas, provide salt-air filtration to prevent corrosion.
- Avoid areas with explosive atmospheres or humidity above 95%.
- Ensure the installation surface is stable, level, non-conductive, and free from contaminants.
- Provide adequate ventilation (natural or forced) to prevent gas buildup in enclosed spaces.
- Inspect the battery and site for damage or obstructions before installation.
- Use only the supplied cables and connectors. Secure the battery to prevent movement or vibration.
- Perform regular maintenance checks for overheating, corrosion, or damage. Disconnect immediately if abnormal conditions occur.

Handling and Mounting Instructions

- **Handle with care:** Always use appropriate lifting equipment or sufficient manpower when moving the battery. Do not drop, drag, or roll the battery.
- Keep the battery upright during transport and installation. Tilting or inverting may cause damage.
- Do not lift or carry the battery by its cables or connectors.
- Avoid impact, vibration, or rough handling.
- Place on a flat, stable, level, and non-conductive surface that can support the full weight of the battery.
- Maintain at least 60 cm clearance at the front and top, and 30 cm at the sides for airflow and heat dissipation.
- If installed in a cabinet or enclosure, provide adequate ventilation or forced airflow.
- Secure the battery firmly to prevent shifting or vibration during operation.



CAUTION

Risk of Injury (Heavy Object).

Be careful to prevent injury when moving heavy objects. Select an suitable way to moving heavy objects according to product weight.

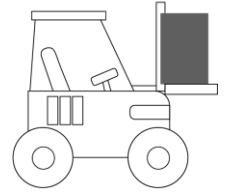
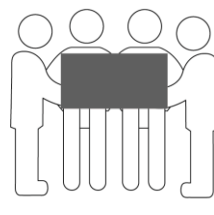
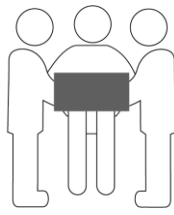
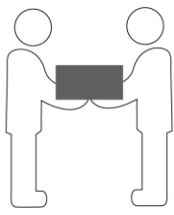
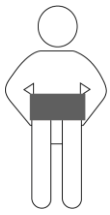

Weight	Method	Recommendation
<18 kg (40lbs)	Manual handling	1 person
18~32 kg (40~70lbs)	Manual handling	2 persons
32~55 kg (40~70lbs)	Manual handling	3 persons
55~68 kg (121~150lbs)	Manual handling	4 persons
> 68 kg (150lbs)	Moving device	Forklift

Layout

If your installation site is limited and the space is relatively narrow, you can refer to the following layout for installation.

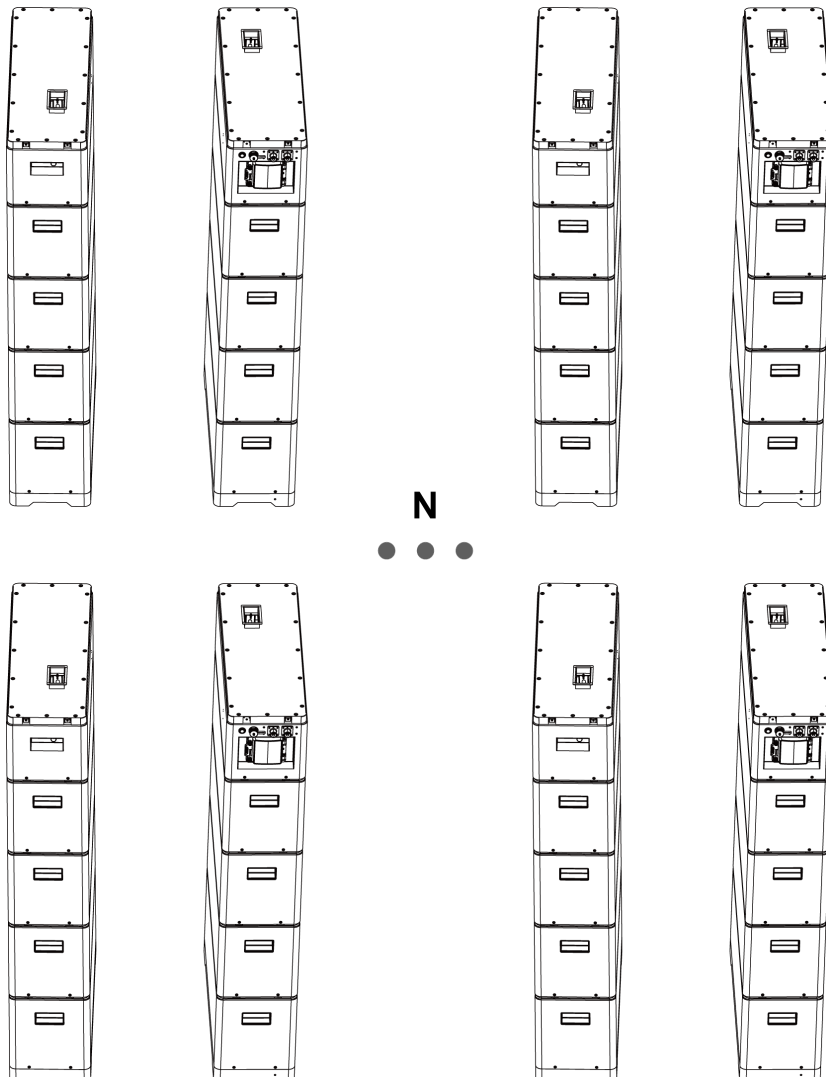

Installation Clearance

The installation location is recommended to meet the size requirements of the figure below:

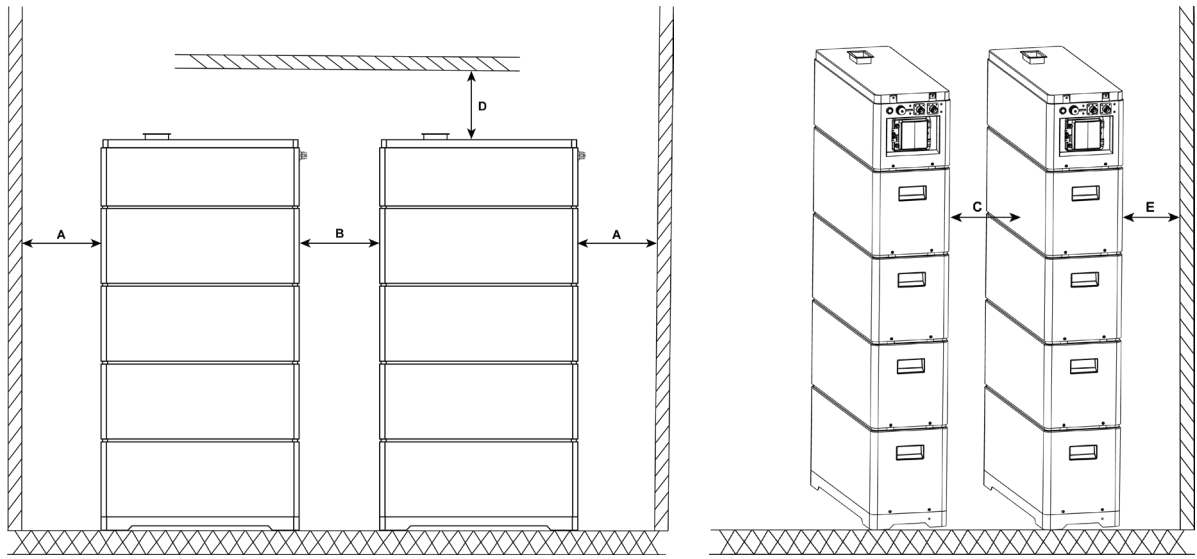

Item	Distance
A	≥600 mm
B	≥300 mm
C	≥20 mm
D	≥600 mm
E	10~35 mm

Installing the Battery

NOTICE

Due to assembly tolerances in the vertical stack, the lower quick-connector is fixed to the enclosure, while the upper quick-connector is designed to float. This guided design ensures a reliable and secure electrical connection between the stacked modules.

Upper and Lower Quick-Connectors

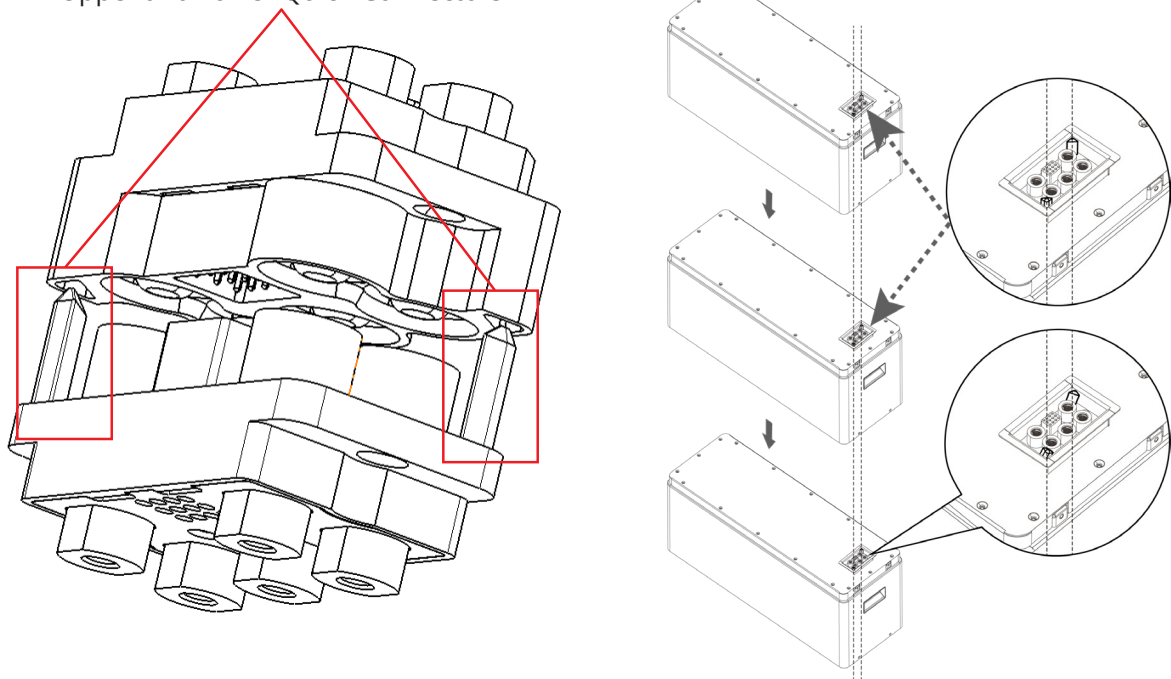

There are two installation methods for you to make a decision. Precede as follows:

! NOTICE

- 1. When drilling holes, pay attention to prevent dust from entering the battery, which may affect the battery performance and function.
- 2. Ensure that the floor is level enough so as to avoid to influence hole drilling, such as height or location.
- 3. After drilling, never forget to clean up the floor.

Method 1

- 1. Take out the base and then put it onto the designated foundation. Stack batteries onto the base in turn and then place the PDU over the battery. Importantly, the quantity of stacked batteries that are regarded as one cluster, is no more than 5.

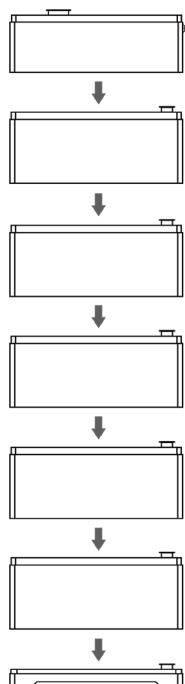

- 2. Secure with screws (M4×8) using a screwdriver.

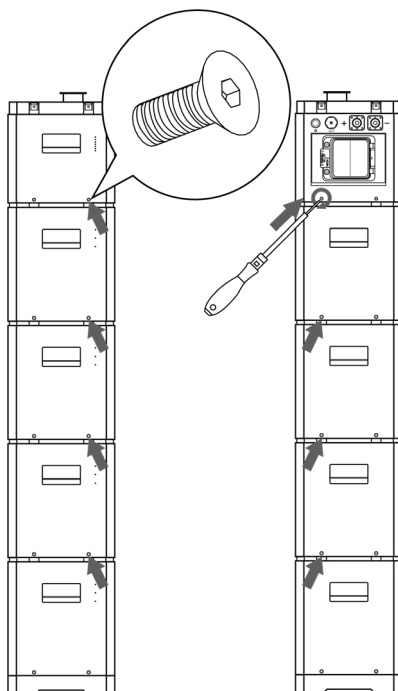

3. Use M4*10 bolts to secure fixed supports to the left and right side of batteries.

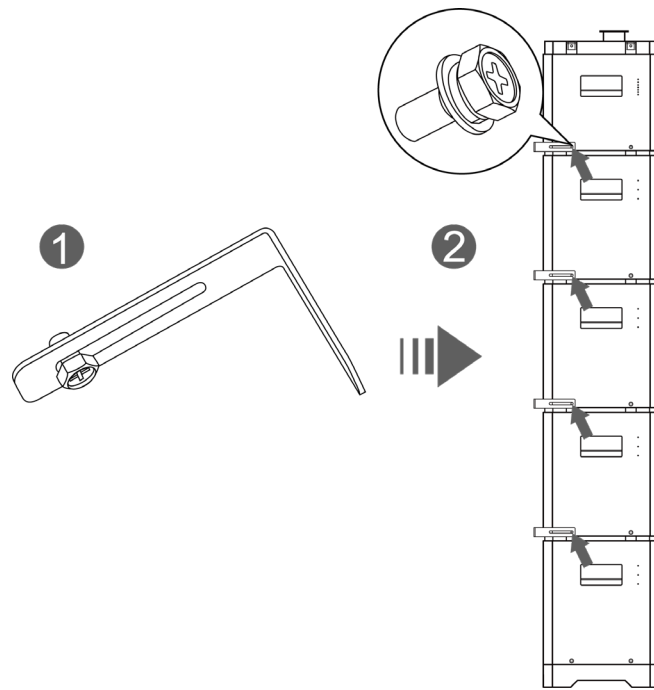

4. Choose appropriate locations on the wall for drilling assembly holes (aperture: 6mm, depth: 50mm).

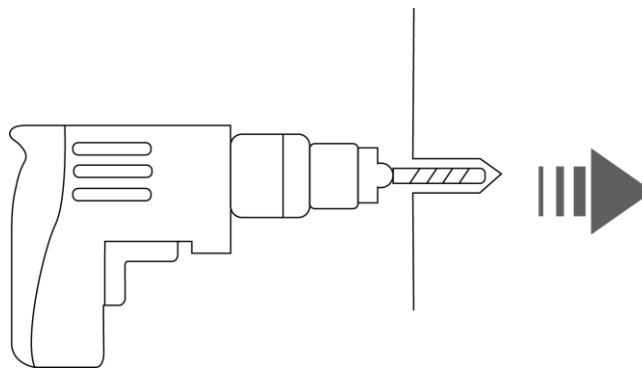

5. Secure batteries to the wall using 8 washers and hex bolts (M8×40).

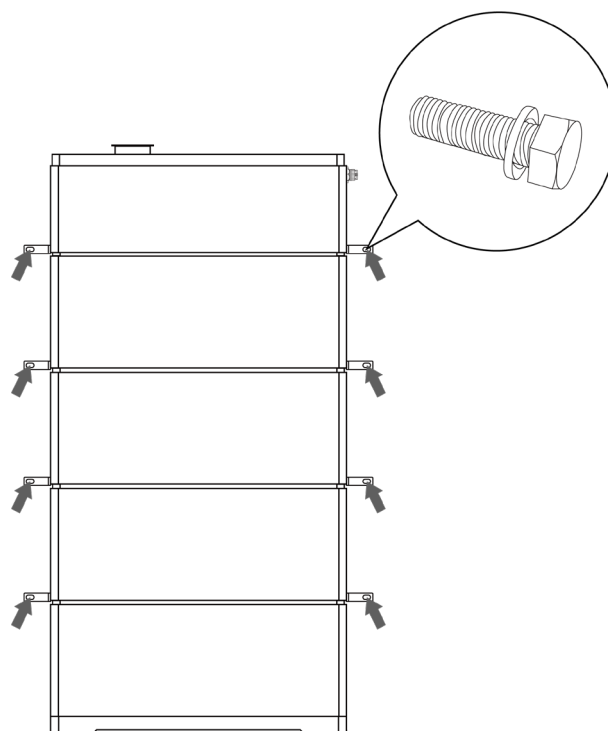

Method 2

1. By rotating clockwise, the adjusting block is fixed on the base, and the length can be adjusted to 40mm.

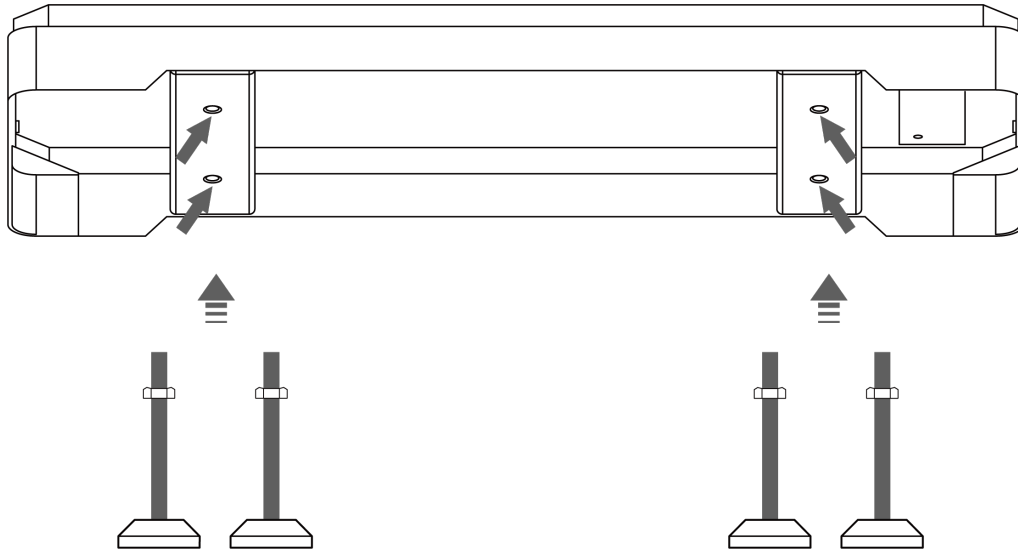

2. Adjust the height of the adjusting block by rotating it.

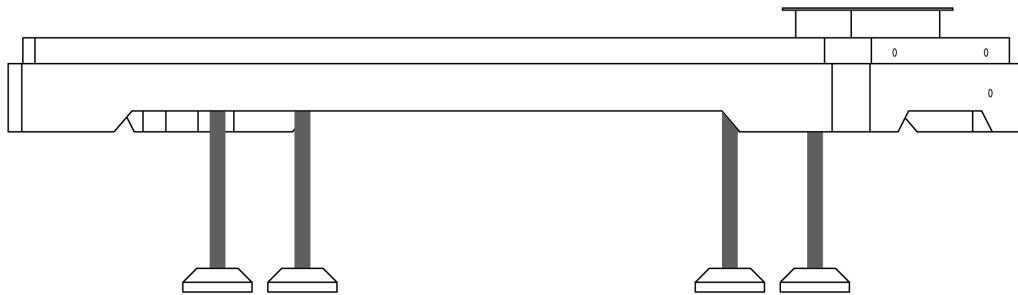

3. Stack battery packs and the PDU, and then secure with screws as mentioned in the Method 1. The quantity of stacked batteries that are regarded as one cluster, is no more than 5.

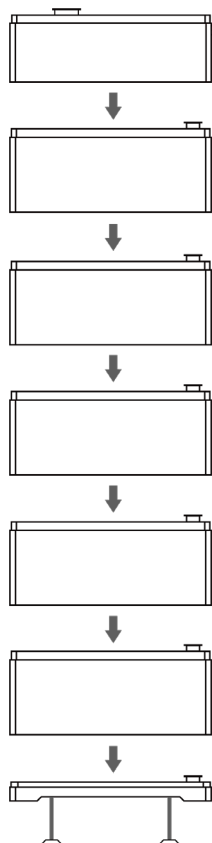

4. Use M4*10 bolts to secure fixed supports to the left and right side of batteries.

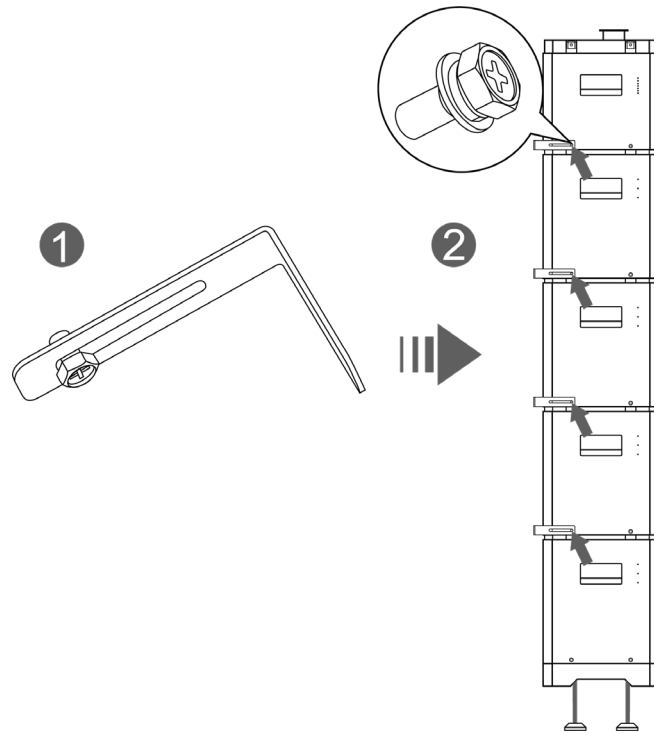

5. Choose appropriate locations on the wall for drilling assembly holes (aperture: 6mm, depth: 50mm).

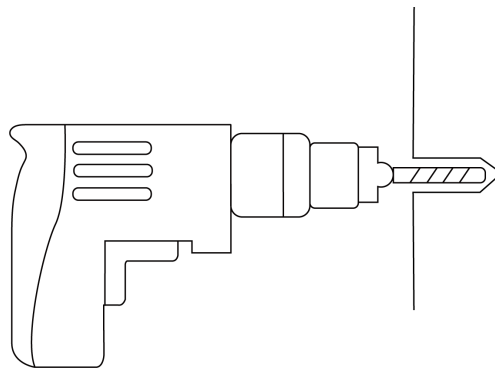

6. Secure batteries to the wall using 8 washers and hex bolts (M8×40).

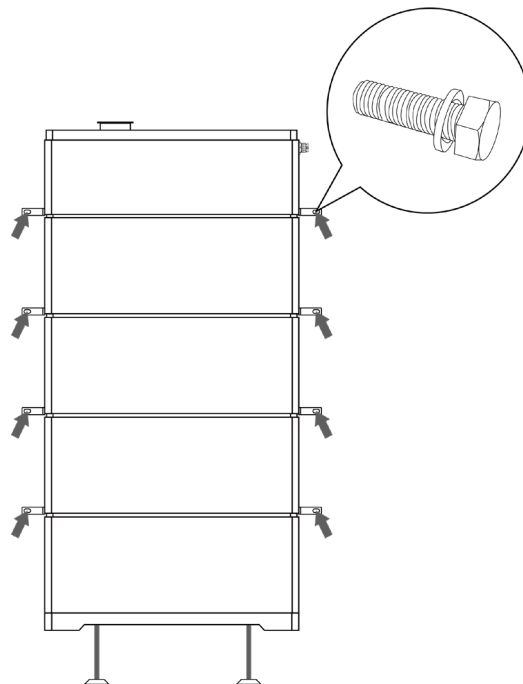

ELECTRICAL CONNECTION

Preparation Before Wiring

Package Contents

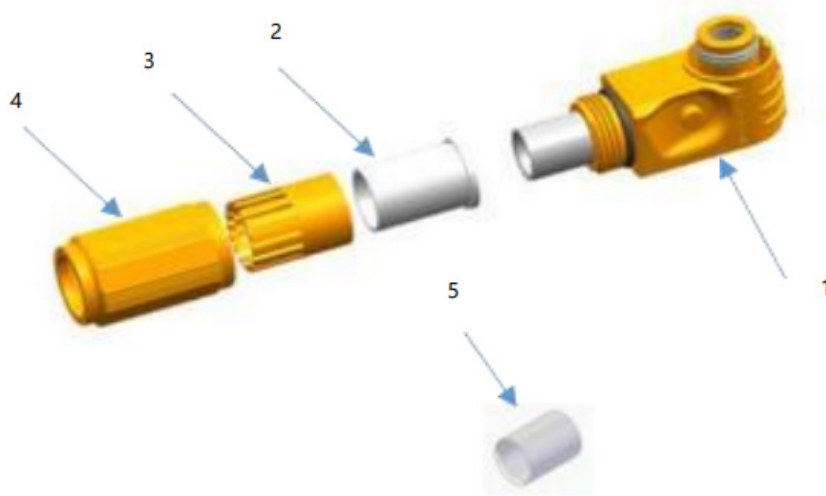

1. Socket Package
2. Grommet
3. Gripping Jaw
4. Nut
5. Barrel Sealing (Only for cable size 35mm²)

Plug Assembly Instruction

Step 1: Strip off the jacket of the cable.



Step 2: Put the nut, the Grommet and the gripping jaw on the cable as shown.



Step 3: Insert the conductor into the lug.

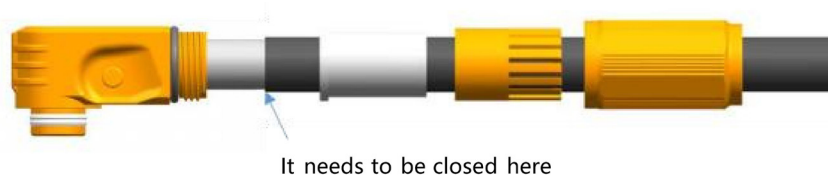

Step 4: Crimping the lug as shown.

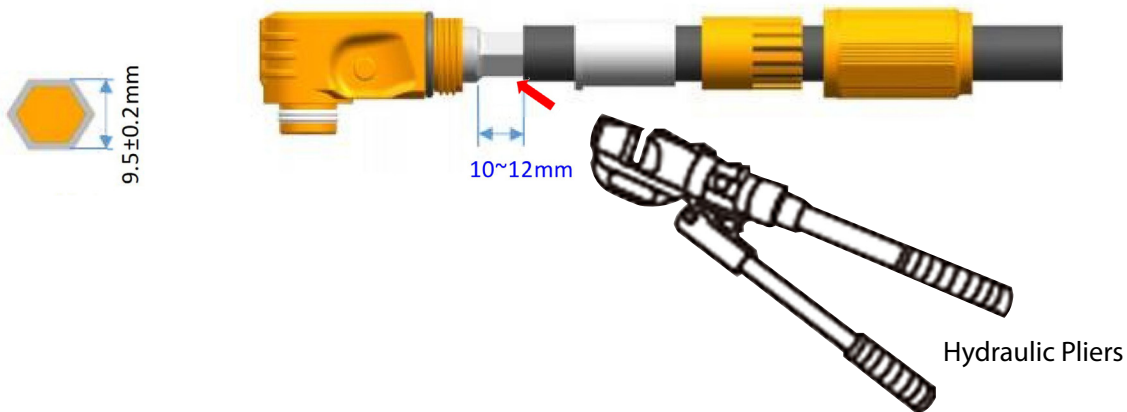

! NOTICE

The recommended crimp sizes are only for reference. The customer should adjust them according to cable specification and crimp tool and test results including temperature rise and metallographic analysis and pullout force.

Step 5: Push the seal, the jaw and the nut into the socket, then screw it.

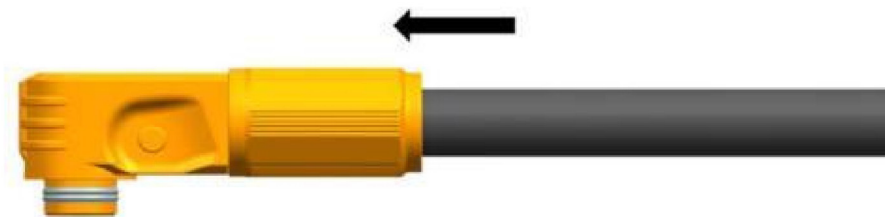

Step 6: Schematic diagram of matching plug and socket.

! WARNING

Do not disconnect under load.

1. Connecting the Socket

- Once the socket is installed, you can connect it directly without pressing the button.
- The connection is complete when you hear a "click" sound.
- To ensure proper assembly, gently pull the socket upward to verify that it is securely in place and cannot be removed.

2. Disconnecting the Plug

- Before disconnecting the plug, make sure to turn off the power.
- Press the release button and then carefully pull out the plug.

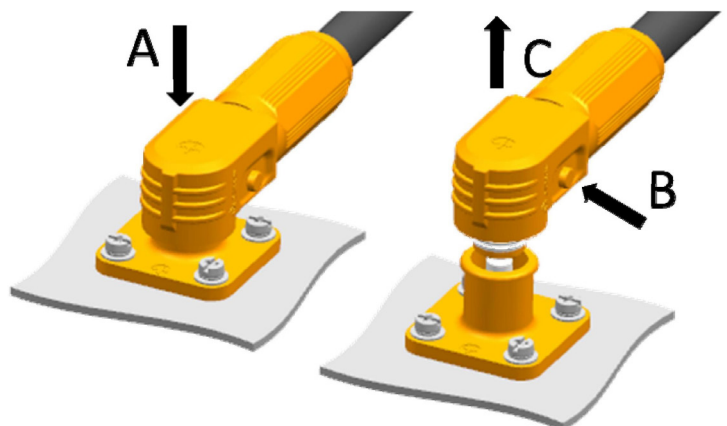

COMMISSIONING

The battery must be installed by qualified personnel, following the relevant national wiring and installation regulations. Prior to powering ON, the qualified personnel must complete the following checks:

- Ensure that the entire system is completely OFF.
- All cables are securely connected (power, ground, and communication).
- Polarity is correct (positive-to-positive, negative-to-negative).
- Communication cable is properly linked between the inverter and battery (CAN → PCS).
- DC fuse breakers and isolators are installed and in the OFF position.
- Cables are neatly routed and secured with no sharp bends or mechanical stress.
- Battery and inverter terminals are tightened, and covers are re-installed.
- Grounding connection is verified.



NOTICE

Ensure that the battery is connected only to a compatible low-voltage inverter. This is a critical requirement for safe and reliable operation.

OPERATION

After successful commissioning, proceed to test system operation by switching it ON. Verify that all communication responses are functioning correctly, recheck cable connections if any abnormal behaviour is observed, and confirm that the battery settings are properly configured.

Before operating the product, ensure that:

- All cables are wired correctly and firmly.
- All fasteners including bolts and screws are tightened firmly.
- No bystanders or animals enter into the working area.
- Keep foreign objects , especially metal, away from the battery.

Start the Battery System

1. Turn on the PCS switch.
2. Turn on the circuit breaker on the PDU.
3. Turn on the BMS switch on the PDU.

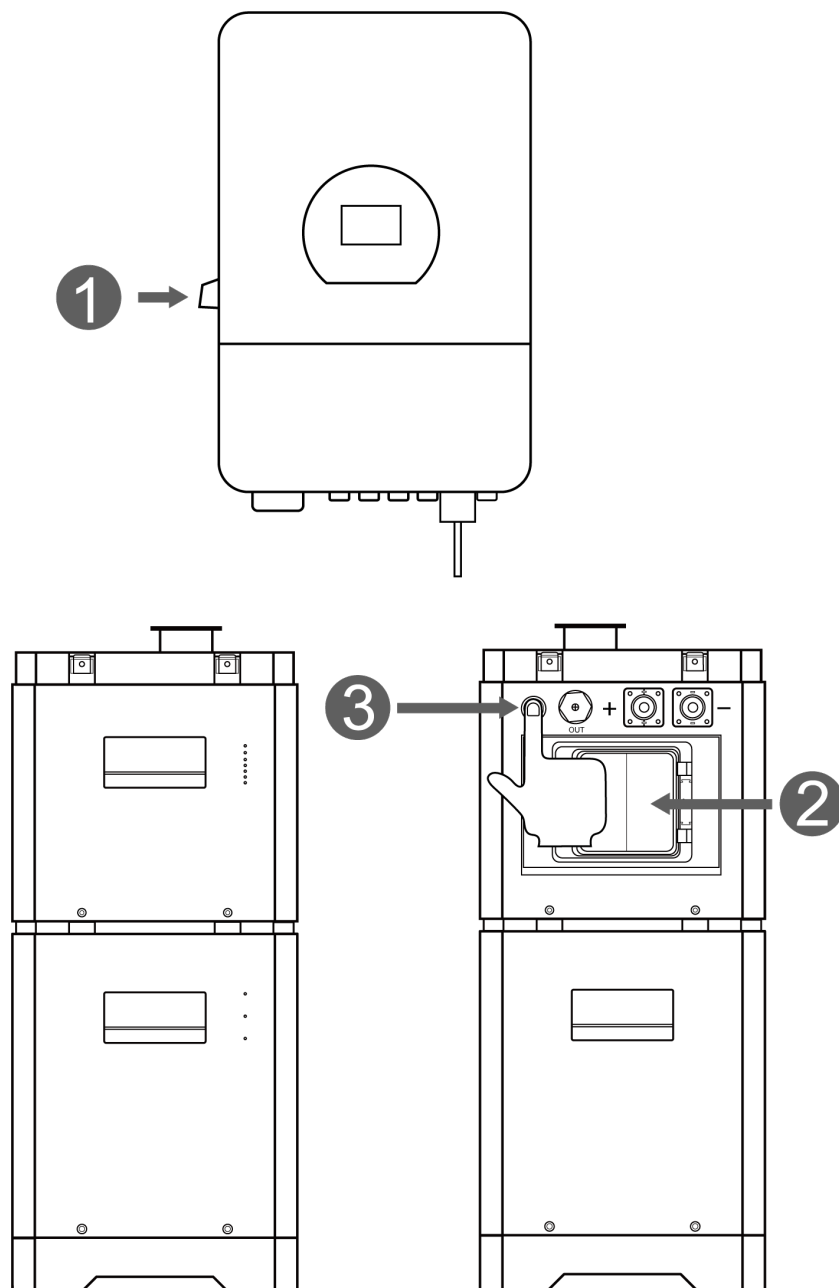

Stop the Battery System

1. Turn off the PCS switch.
2. Turn off the BMS switch on the PDU.
3. Turn off the circuit breaker on the PDU.

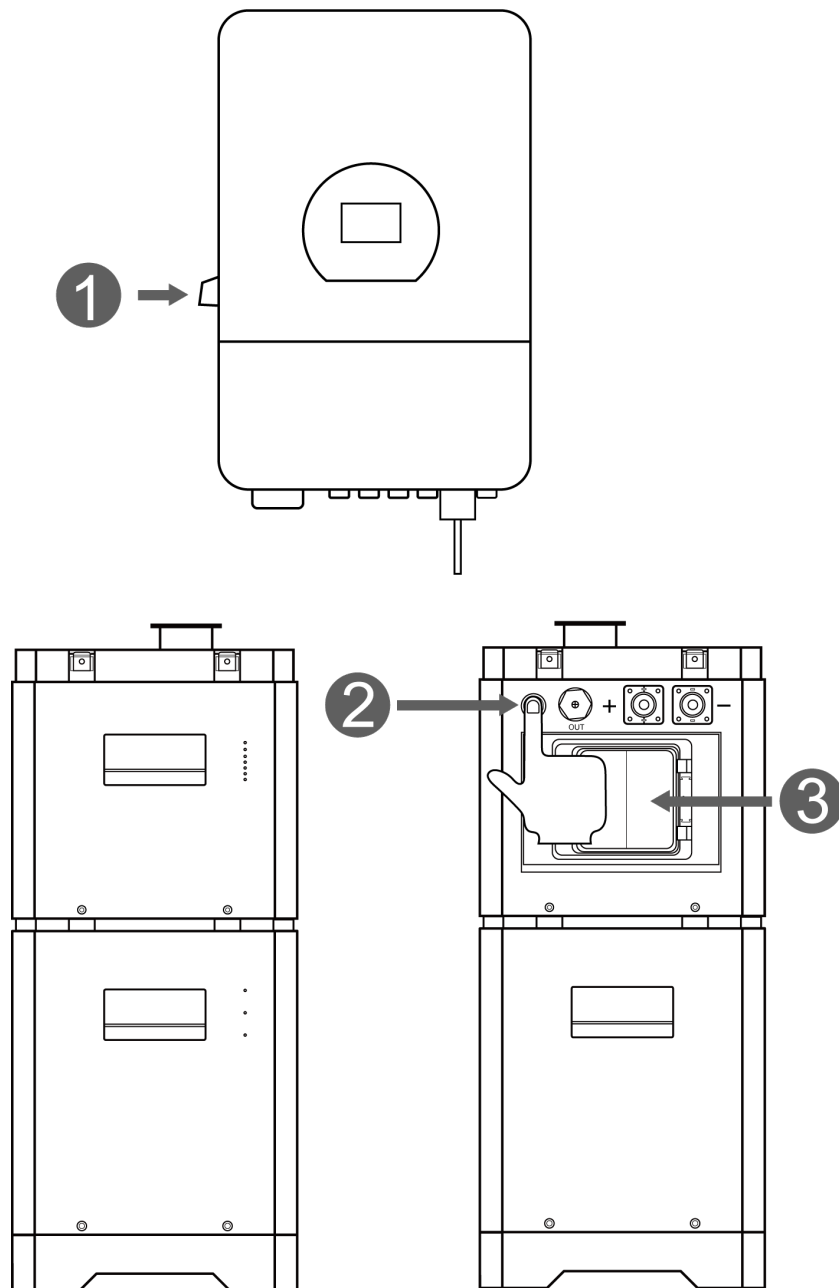

WARNING

Never connect or disconnect battery cables while the system is powered ON.

- Always follow the correct order: Start-Up (Battery → Inverter), Shut-Down (Inverter → Battery).
- Wait at least 5 minutes after shut-down before touching cables or components.
- Refer to section **Model Interface Description and Instructions** for LED indicators and PDU warnings.

TROUBLESHOOTING

To assess the battery system's status, users need to utilize additional battery status monitoring software to check the protection mode. Please refer to the installation manual for instructions on using the monitoring software. Once the user identifies the protection mode, consult the following table for solutions and further information.

Fault Type	Fault Generation Condition	Possible Causes	Troubleshooting
BMS fault	The cell voltage sampling circuit is faulty. The cell temperature sampling circuit is faulty	The welding point for cell voltage sampling is loose or disconnected. The voltage sampling terminal is disconnected. The fuse in the voltage sampling circuit is blown. The cell temperature sensor has failed.	Replace the battery.
Electrochemical cell fault	The voltage of the cell is low or unbalanced.	Due to large self-discharge, the cell over-discharges to below 2.0V after long-term storage. External factors damage the cell, and short circuits, pinpricks, or crushing occurs.	Replace the battery.
Over-voltage protection	The cell voltage is greater than 3.65 V in the charging state. The battery voltage is greater than 58.4 V.	The busbar input voltage exceeds the standard value. Cells are not consistent. The capacity of some cells deteriorates too fast, or the internal resistance of some cells is too high.	Contact local engineers to rectify the fault if the battery cannot be recovered due to protection against abnormality.
Under voltage protection	The battery voltage is less than 44.8V. The minimum cell voltage is less than 2.8V	The mains power failure has lasted for a long time. Cells are not consistent. The capacity of some cells deteriorates too fast, or the internal resistance of some cells is too high.	Contact local engineers to rectify the fault if the battery cannot be recovered due to protection against abnormality.
Charge or discharge high-temperature protection	The maximum cell temperature is greater than 60°C	The battery ambient temperature is too high. There are abnormal heat sources around.	Contact local engineers to rectify the fault if the battery cannot be recovered due to protection against abnormality.
Charge low-temperature protection	The minimum cell temperature is less than 0°C	The battery ambient temperature is too low.	Contact local engineers to rectify the fault if the battery cannot be recovered due to protection against abnormality.
Discharge low-temperature protection	The minimum cell temperature is less than -20°C	The battery ambient temperature is too low.	Contact local engineers to rectify the fault if the battery cannot be recovered due to protection against abnormality.

After reviewing the provided data, please forward it to our customer service team. They will assess your issue and provide you with the most suitable solution.

MONITORING

Sunsynk battery monitoring is easily accessible via the Sunsynk Connect and Sunsynk Connect Pro apps. Sunsynk inverter systems use the CANBUS protocol to maintain continuous communication with connected batteries. To enable monitoring of battery functionality and performance, a data logger must be properly connected to the inverter and to Wi-Fi, and a site plant must be created via the Sunsynk Connect or Sunsynk Pro apps. For detailed instructions on the Sunsynk Connect or Sunsynk Connect Pro app and setting up system monitoring, refer to the Sunsynk Connect or Sunsynk Connect Pro User Manual on sunsynk.org

The following illustrations show how to register, create a plant for a site and monitor a battery online with ease.

Data Logger Installation

- 1 Insert the Data Logger into the DB9 interface of the inverter, as shown in the following figure.

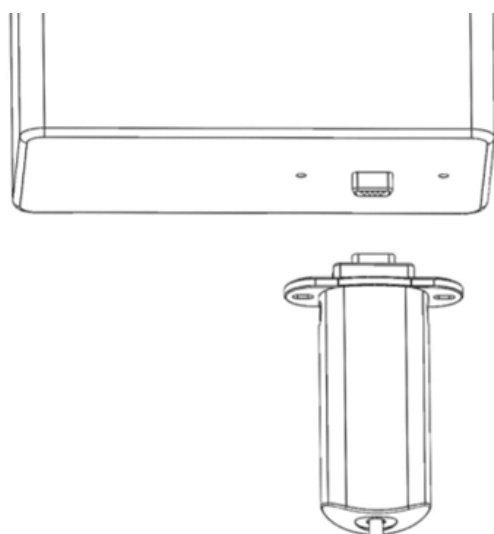

- 2 Insert the two screws that come with the Data Logger through the holes, and then tighten them with a Phillips screwdriver, as shown in the figure below.

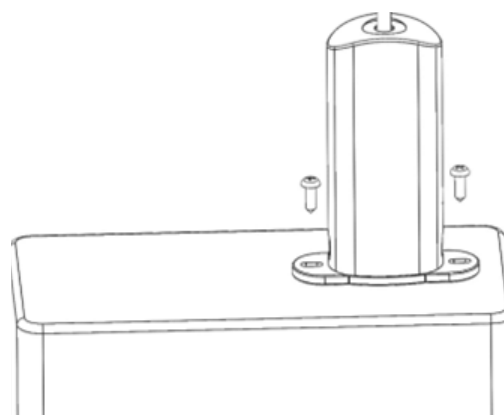

Connecting to Wi-Fi

To connect the data logger to the Wi-Fi you need to go to the Wi-Fi setting on your device and search for it. You will see an available connection with the SSID 'EAP-*****' ('*****' are the last 5 digits of the serial number on the data logger).

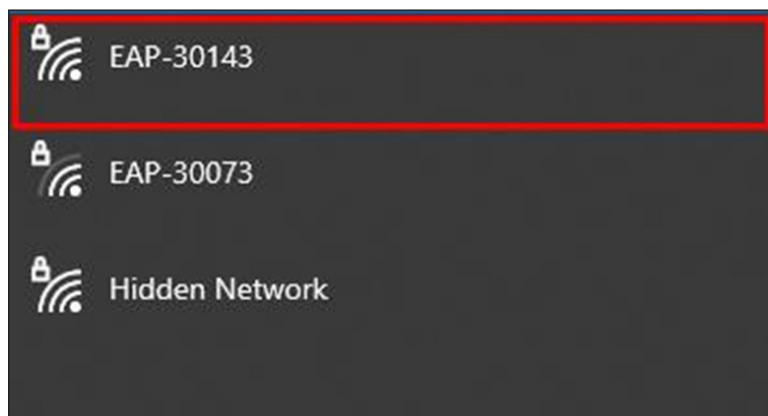

- 1 Select the correct connection and then enter the password 12345678.

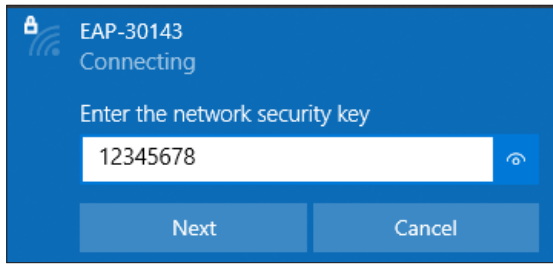

- 2 Once you have connected to the EAP connection, you need to connect it to your own Wi-Fi. To do this, open the Internet browser and search the IP address 10.10.10.1.

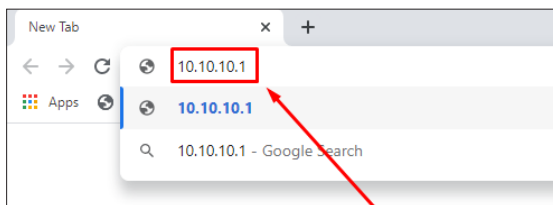

- 3 Once connected, click 'Scan' to search the Wi-Fi List and you should then see your Wi-Fi connection.

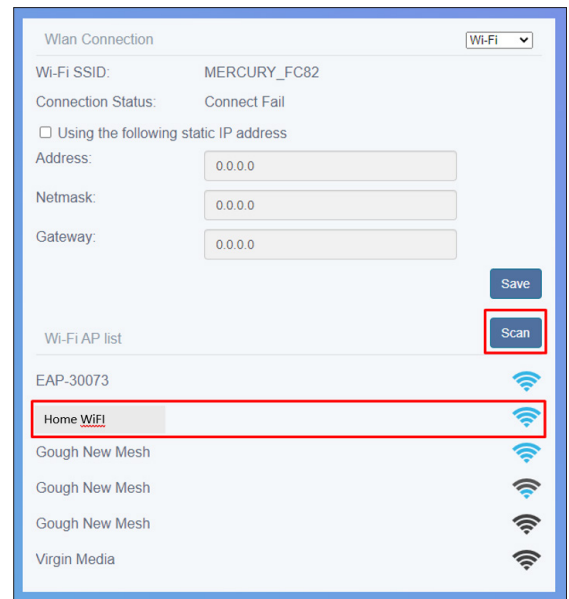

- 4 Select your Internet / Wi-Fi connection, enter your password, and click 'Connect'.

- 5 Once your data logger is connected to your Wi-Fi, you can then disconnect from the data loggers EAP connection and connect back to your usual Wi-Fi connection.

Network Cable

- 1 Use a flat-blade screwdriver to press the buckles on the left and right sides of the shell, as shown in the following figure. Then extract the DB9 interface part manually.

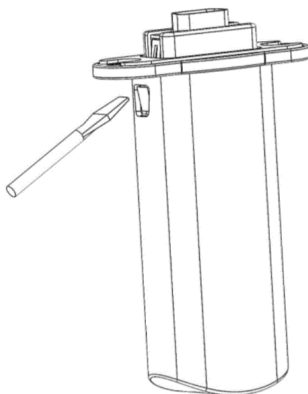

- 2 Pass the network cable through its specific hole at the bottom of the shell. Then, insert the RJ45 plug into the RJ45 socket, and place the sealing plug with the hole on the network cable, as shown in the figure below.

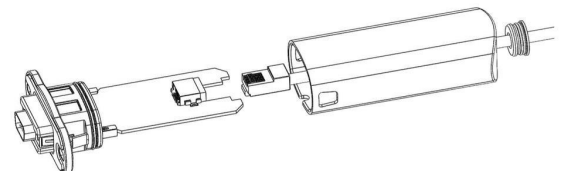

Registration

1 Visit <https://sunsynk.net> in your browser to access the web version of the management tool. Click on 'Sign Up' on the Login page to proceed to the Registration page.

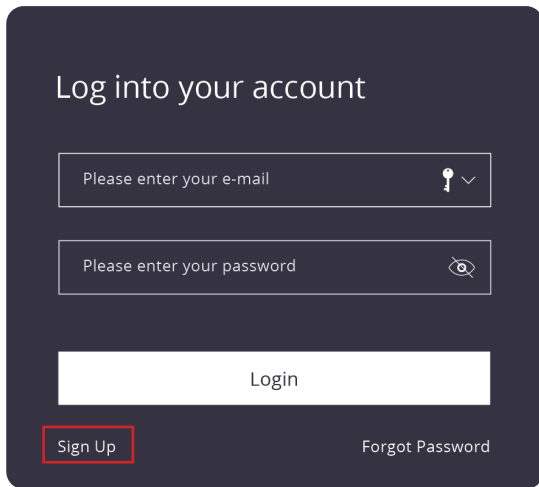

The screenshot shows a dark-themed login page titled "Log into your account". It features two input fields: "Please enter your e-mail" with a key icon and "Please enter your password" with an eye icon. Below these is a "Login" button. At the bottom left, the "Sign Up" button is highlighted with a red box. At the bottom right, there is a "Forgot Password" link.

2 Enter a valid email address to receive a verification code. Complete the registration form by setting a password, checking the user agreement box to confirm agreement, and then click 'Agree and Register'.

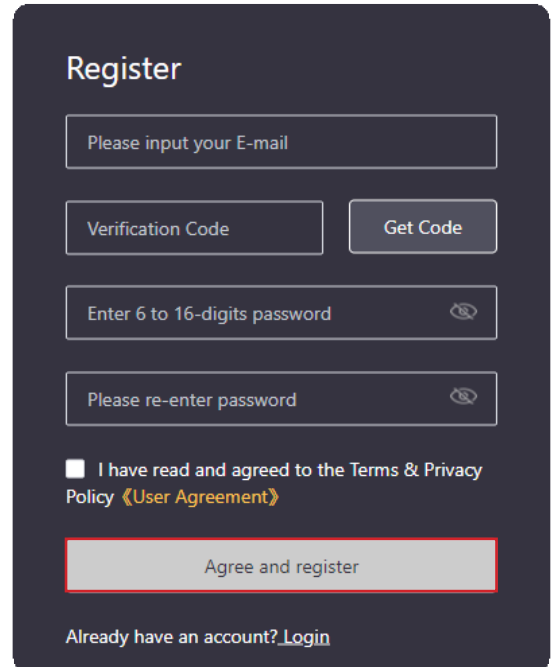

The screenshot shows a dark-themed registration page titled "Register". It includes an email input field, a "Verification Code" field, and a "Get Code" button. Below is a password input field with the instruction "Enter 6 to 16-digits password" and an eye icon, followed by a "Please re-enter password" field with an eye icon. A checkbox is present with the text "I have read and agreed to the Terms & Privacy Policy" and a link to "User Agreement". The "Agree and register" button is highlighted with a red box. At the bottom, there is a link: "Already have an account? Login".

Requesting User Level Access Change

If you are an installer who has registered on the Sunsynk Connect platform, you may initially have a basic user account with limited permissions. To request elevated user access for parameter changes, remote inverter upgrades, and other functions, please visit <https://www.sunsynk.org/remote-monitoring> and complete the form provided.

Creating a Plant

1 Navigate to the menu and click on 'My Plant', then select 'Plant List'.

2 To initiate a new plant setup, click on 'Create a Plant' located in the right of the page.

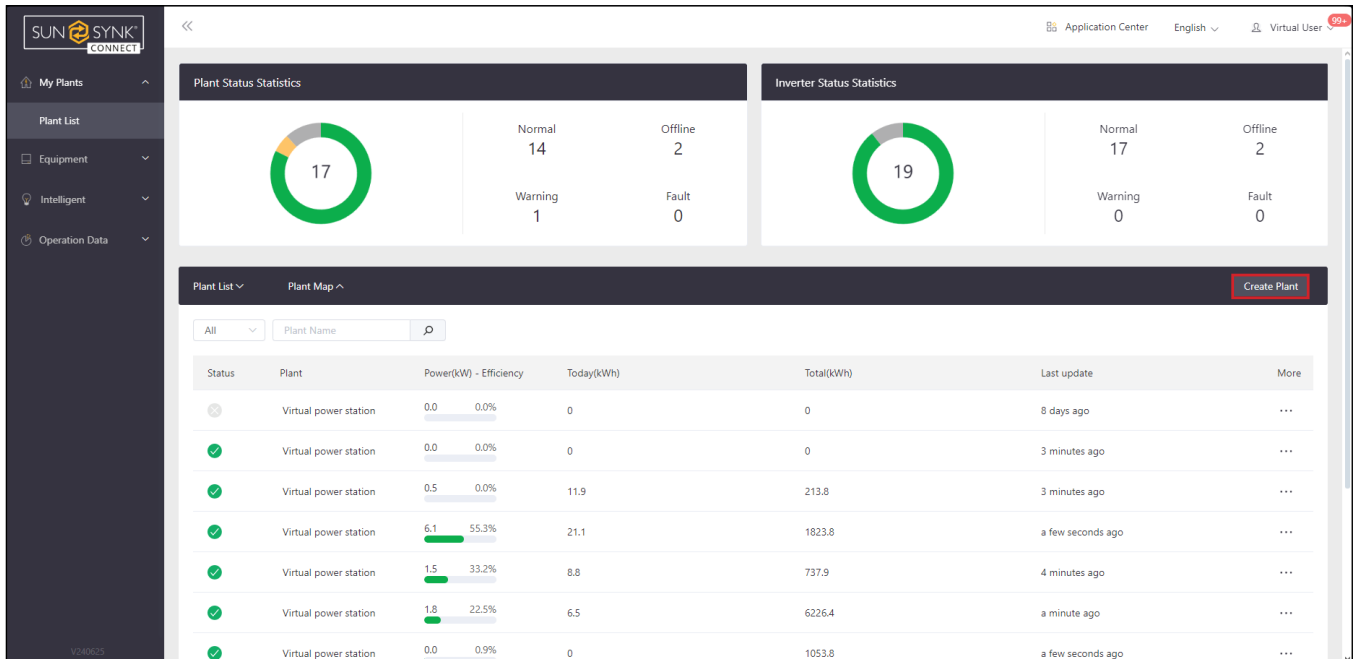

3 Enter the Serial Number (SN) and KEY from the Data Logger label, then click 'Next'.

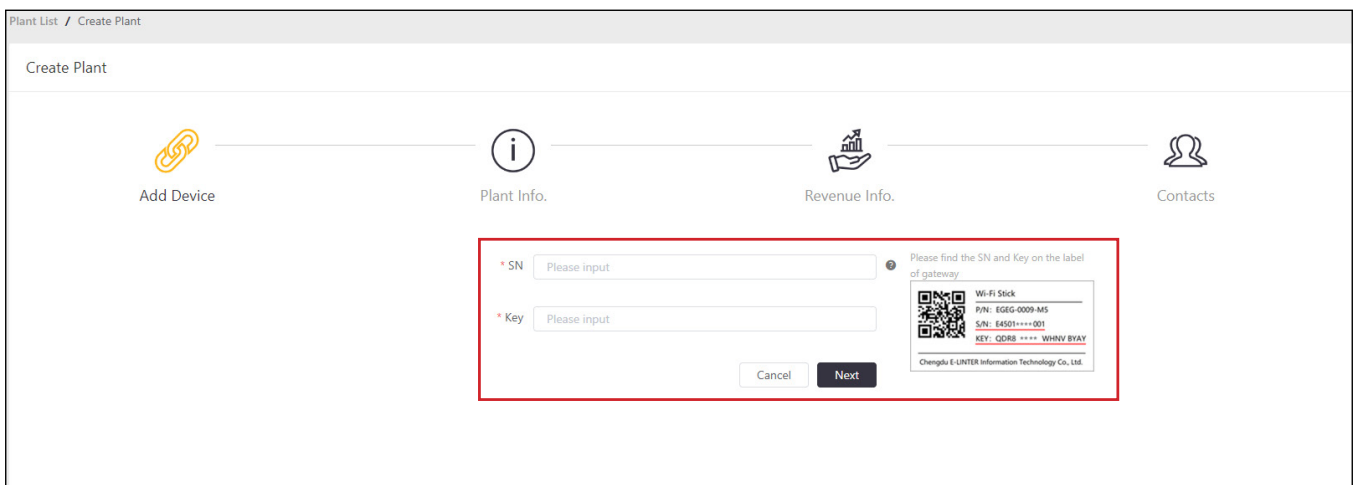

4 Specify the total capacity in the 'Capacity' field and choose the appropriate 'Plant Type'. Note that different types of plants will display different information on the page. To ensure accurate plant statistics, complete all required fields accurately.

5 Enter the installation address of the plant in the address input box on the map to pinpoint the exact location, or use the map to select the correct installation site.

6 Verify and adjust the plant's time zone if necessary. Click 'Next' to proceed.

Plant List / Create Plant

Create Plant

Add Device Plant Info. Revenue Info. Contacts

4

* Plant Name

* Capacity MW

* Commissioning Date

Installer

Upload picture. The file format must be JPG, PNG, PNG, and size can not exceed 10MB

5

6

Longitude and latitude: -2.715839,53.370591

Address: 60 Frank St, Widnes WAB, Cheshire, UK

* Time Zone: (UTC+04:00)Azerbaijan Ulyanovsk Check whether the selected time zone is correct

Back Next

7 Select your currency, specify the total investment, and choose your preferred Valuation Method.
Note: The Live Price option is currently available only for UK customers.

Plant List / Create Plant

Create Plant

Add Device Plant Info. Revenue Info. Contacts

* Currency: \$

Total Investment: \$

* Valuation Method: Constant Price Time of use price Live Price

\$/kWh

Back Next

8 Provide the name, phone number, and email address of the user responsible for managing the system.

Plant List / Create Plant

Create Plant

Add Device Plant Info. Revenue Info. Contacts

* Manager:

* Phone:

E-mail:

Back Complete

Adding a Device

- 1 In the menu, first click 'My Plant', then 'Plant List'.
- 2 Select the plant that need to add equipment from the 'Plant List'.
- 3 Click the 'More (...)' button and Select 'Add Gateway'.

The screenshot shows the SUN SYNK CONNECT dashboard. The left sidebar has 'My Plants' selected, with 'Plant List' highlighted. The main area displays 'Plant Status Statistics' and 'Inverter Status Statistics'. Below these is the 'Plant List' table with columns: Status, Plant, Power(kW) - Efficiency, Today(kWh), Total(kWh), Last update, and More. The first row is highlighted in red. A 'More' menu is open for this row, with 'Add Gateway' selected.

Status	Plant	Power(kW) - Efficiency	Today(kWh)	Total(kWh)	Last update	More
⊗	Virtual power station	0.0 0.0%	0	0	4 days ago	⋮
✔	Virtual power station	0.0 0.0%	0	0	a minute ago	⋮
✔	Virtual power station	0.3 0.0%	4.8	170.1	a few seconds ago	⋮
✔	Virtual power station	1.2 10.6%	20.8	1719.4	2 minutes ago	⋮

- 4 Input the serial number SN and key of the Data Logger to be connected, then click 'Confirm'.

The screenshot shows the SUN SYNK CONNECT dashboard with an 'Add Gateway' dialog box open. The dialog box has two input fields: 'SN' and 'Key', both with 'Please input' text. There are 'Cancel' and 'Confirm' buttons at the bottom.

Editing a Plant

- 1 In the menu, first click 'My Plant', then 'Plant List'.
- 2 Select the plant that need to be edited from the 'Plant List'.
- 3 Click the 'More (...)' button and select 'Edit'.

The screenshot shows the SUN SYNK CONNECT dashboard. The left sidebar has 'My Plants' selected, with 'Plant List' highlighted. The main area displays 'Plant Status Statistics' and 'Inverter Status Statistics'. Below these is the 'Plant List' table with columns: Status, Plant, Power(kW) - Efficiency, Today(kWh), Total(kWh), Last update, and More. The first row is highlighted in red. A 'More' menu is open for this row, with 'Edit' selected.

Status	Plant	Power(kW) - Efficiency	Today(kWh)	Total(kWh)	Last update	More
⊗	Virtual power station	0.0 0.0%	0	0	4 days ago	⋮
✔	Virtual power station	0.0 0.0%	0	0	a minute ago	⋮
✔	Virtual power station	0.3 0.0%	4.8	170.1	a few seconds ago	⋮
✔	Virtual power station	1.2 10.6%	20.8	1719.4	2 minutes ago	⋮

4 Review and make edits to any previously entered information as needed.

Plant Overview

1 In the menu, first click 'My Plant', then 'Plant List'.

2 Select plant list 'Plant List' and click the corresponding plant name to enter the plant Overview page.

Status	Plant	Power(kW) - Efficiency	Today(kWh)	Total(kWh)	Last update	More
✓	Virtual power station	0.5 9.5%	3.4	4265.9	5 minutes ago	...
✓	Virtual power station	4.5 37.7%	22.9	13551.1	4 minutes ago	...
✓	Virtual power station	0.4 5.6%	9.8	5679.4	a minute ago	...

3 On the Plant Overview page, you can monitor the plant's status, weather conditions, energy flow diagram, inverter status, recent abnormalities, power generation charts, and other relevant information (as illustrated on the next page).

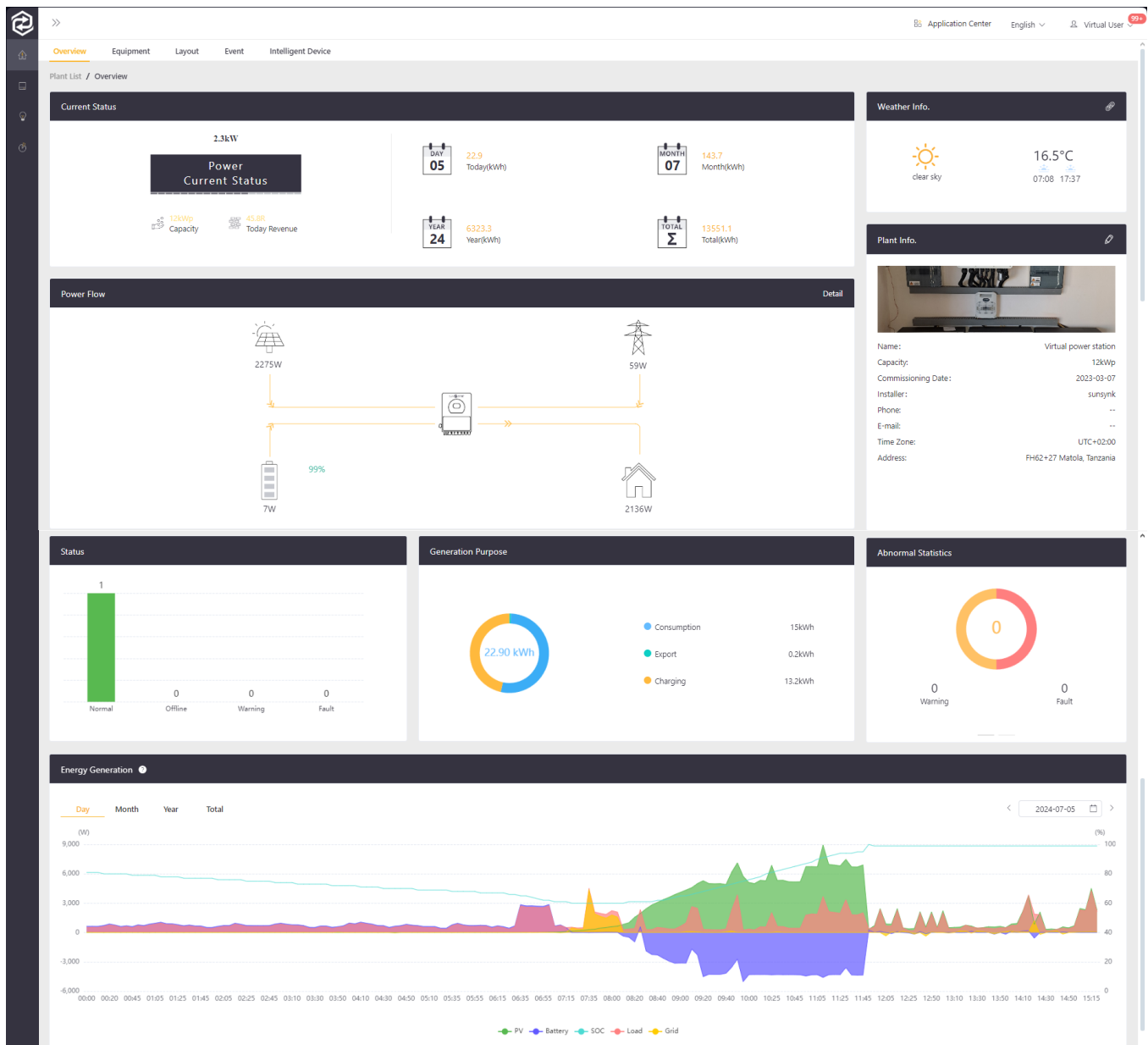

4 Click on 'Equipment' within the Overview page to access detailed information about all equipment installed in the plant. Here, you can view operational data charts, perform remote upgrades, adjust parameter settings, and manage other operations.

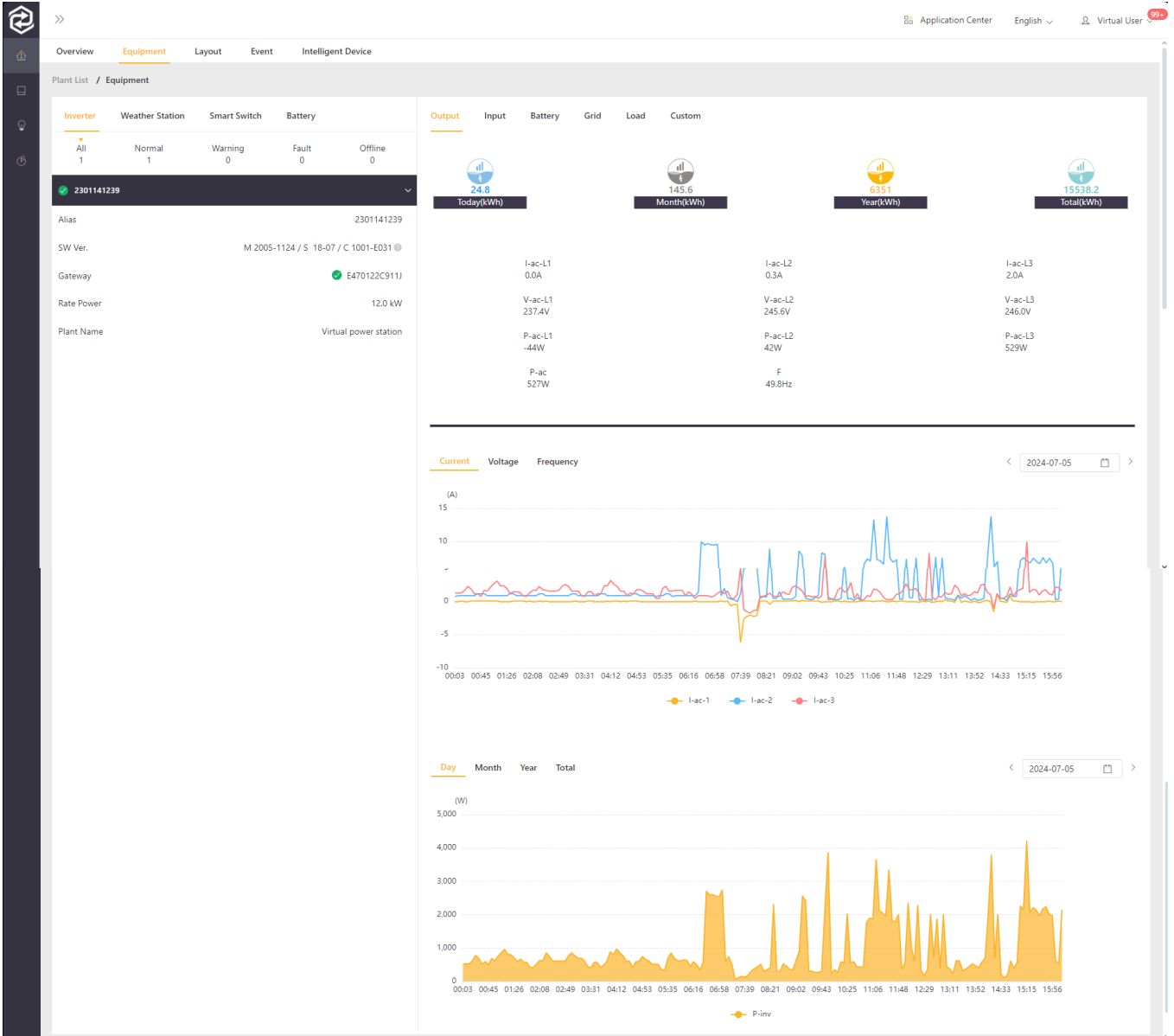

5 On the Plant Layout page, you can monitor the plant's layout.

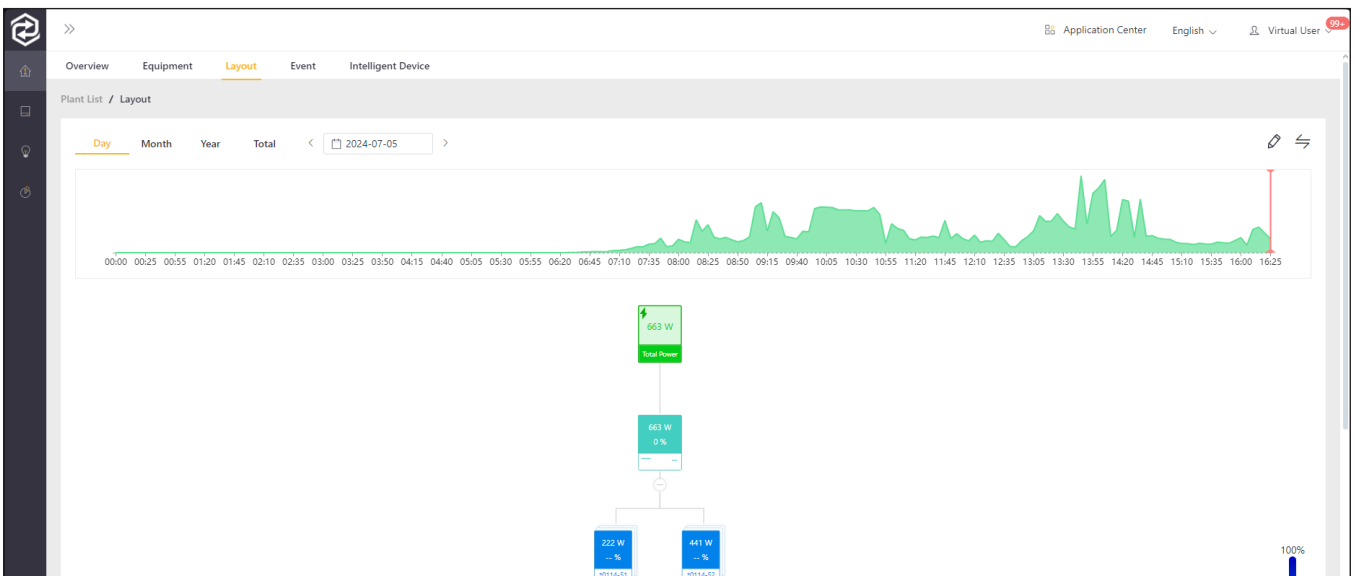

6 Navigate to the 'Event' menu on the Plant Overview page to switch to the Event page. Here you can view the current plants abnormal information.

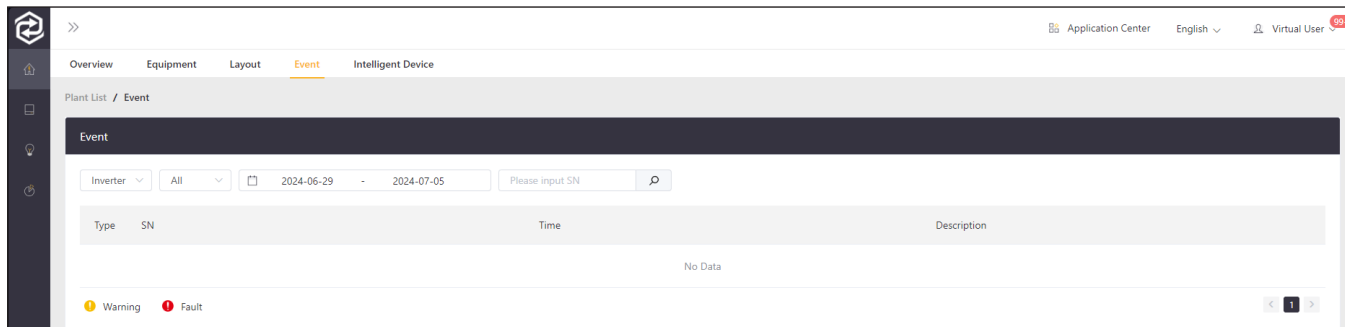

7 On the Plant Intelligent device...

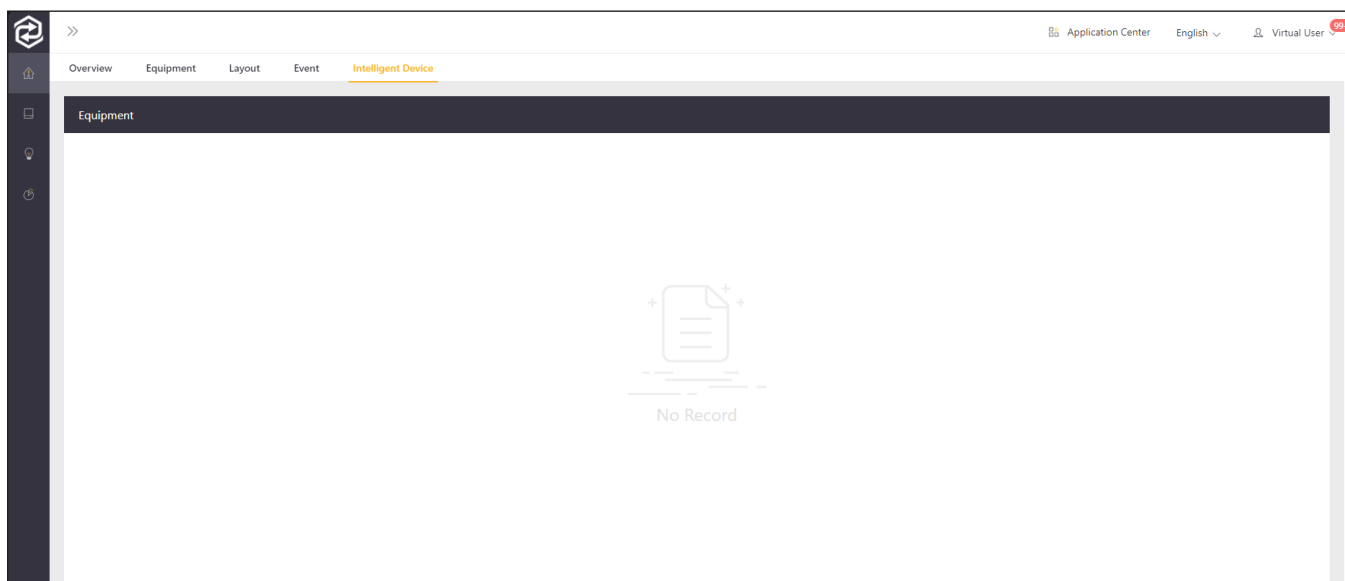

Battery Management

1 In the menu, click 'Equipment', then 'Battery' to enter the Battery List page.

2 On the Battery List page, click on the serial number (SN) of a battery to view its detailed information and operational data.

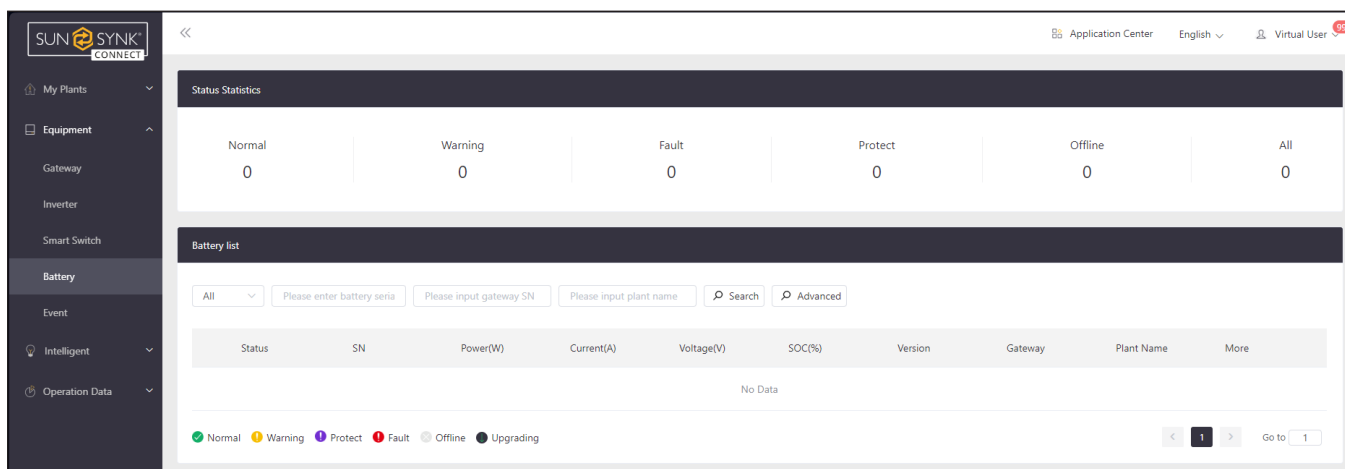

Event

1 In the menu, click 'Equipment', then 'Event' to enter the Event List page.

2 In the Event List page, click on the SN of an inverter to view the detailed information of the event and recent operational data.

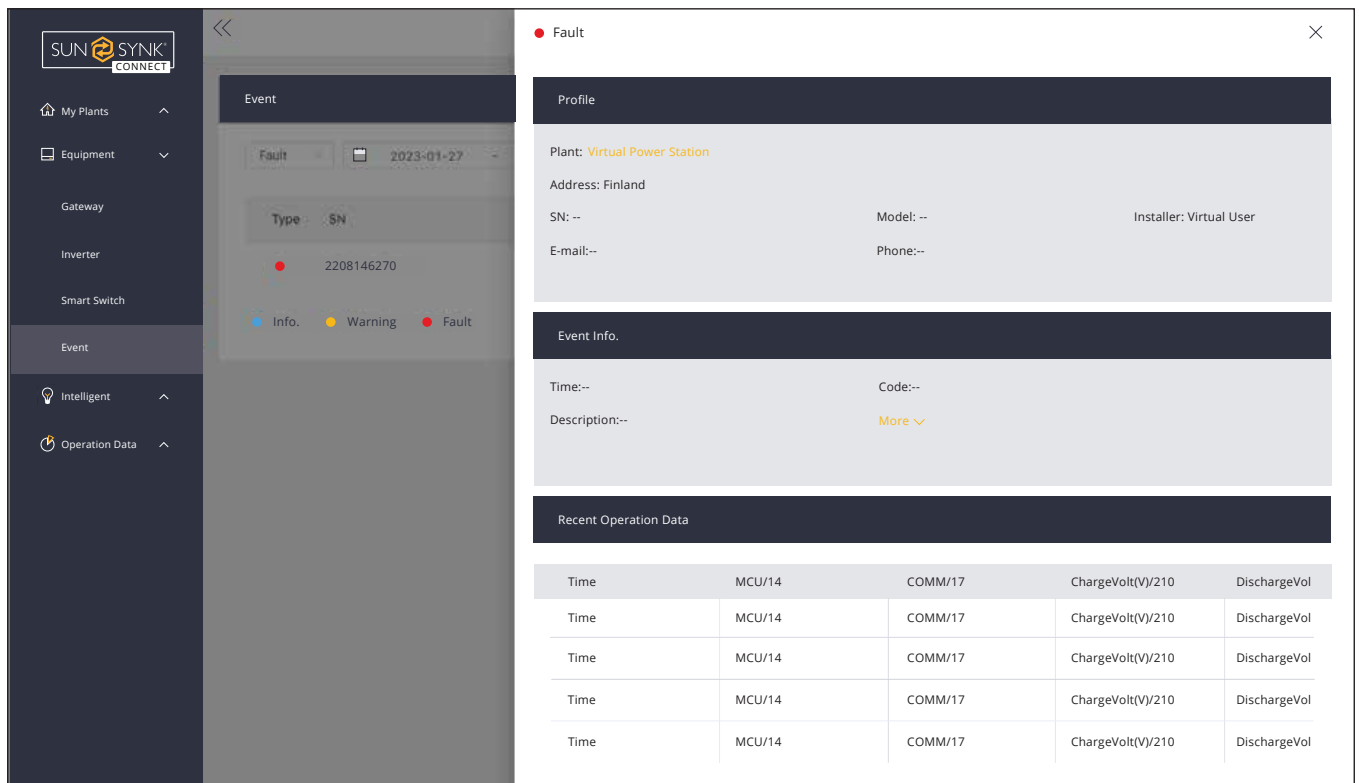
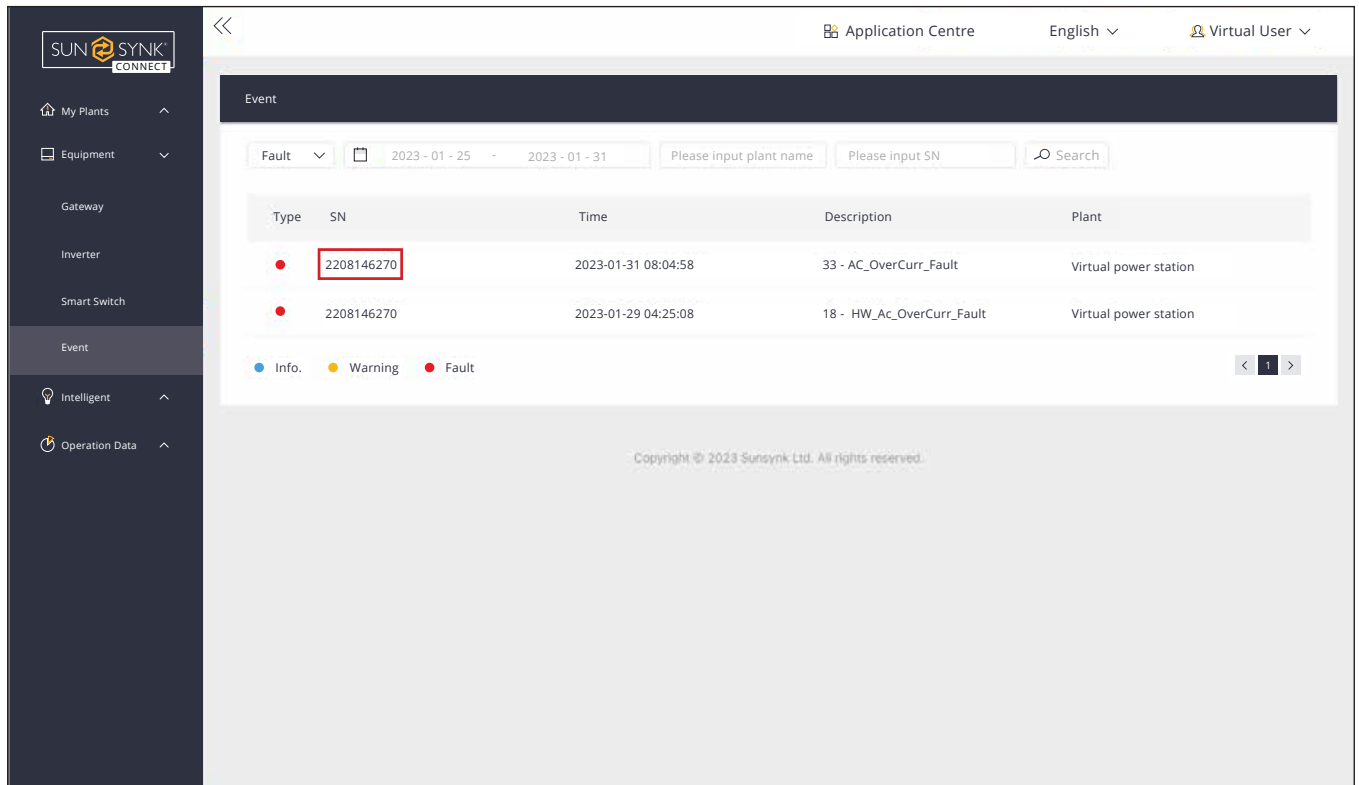

INSPECTION, CLEANING AND MAINTENANCE

General Information

- The Sunsynk Elite 5.1kWh BATT IP65 battery isn't fully charged upon shipment. We suggest installing it within three months of arrival.
- During maintenance, avoid reinstalling batteries in the Sunsynk Elite 5.1kWh BATT IP65 to prevent reduced product performance.
- Do not dismantle or dissect any battery in the Sunsynk Elite 5.1kWh BATT IP65; it's strictly prohibited.
- After over-discharging the Sunsynk Elite 5.1kWh BATT IP65 battery, recharge it within 48 hours. You can also charge the Sunsynk Elite 5.1kWh BATT IP65 in parallel. Connect the charger to the output port of any Sunsynk Elite 5.1kWh BATT IP65 after connecting batteries in parallel.
- Do not open or dismantle the battery as it doesn't contain serviceable parts internally.
- Before cleaning or performing maintenance tasks, disconnect the Sunsynk Elite 5.1kWh BATT IP65 battery from all loads and charging devices. Use the enclosed protective caps on terminals during these activities to avoid terminal contact risks.

Inspection

Inspect the wiring and contacts for looseness or damage, including cracks, deformations, leaks, or any other type of damage. If any damage is found, replace the battery immediately.

- Do not attempt to charge or use damaged batteries under any circumstances.

IMPORTANT: Avoid contact with liquid from a ruptured battery.

Regularly monitor the battery's state of charge. Lithium Iron Phosphate batteries gradually discharge when not in use or during storage. Consider replacing the battery if you notice either of the following conditions:

1. The battery's run time decreases below 70% of the original run time.
2. The battery's charge time significantly increases.

Cleaning

If cleaning is required, use a soft, dry cloth to clean the Li-Ion battery. Avoid using liquids, solvents, or abrasives for cleaning purposes.

Maintenance

The Li-Ion battery is maintenance-free. Charge the battery to approximately over 80% of its capacity at least once every year to maintain its capacity.

STORAGE

The battery product should be stored in a dry and cool environment. Typically, the maximum storage period at room temperature is six months. If storing the battery for over six months, it's recommended to check the battery voltage. If the voltage exceeds 51.2V, you can continue storing the battery. However, it's important to check the voltage at least once a month until it drops below 51.2V. Once the voltage is lower than 51.2V, charge the battery according to the following strategy:

1. Discharge the battery to the cut-off voltage using a 0.2C (20A) current.
2. Charge the battery with a 0.2C (20A) current for approximately 3 hours.
3. Maintain the State of Charge (SOC) of the battery at 40%-60% during storage.

When storing the battery, ensure it's kept away from explosive and flammable areas, and keep ignition sources and high temperatures distant from the battery.

BATTERY RECOVERY

The advanced hydro-metallurgical process is used to recover aluminium, copper, lithium, iron, and other metal materials from discarded LiFePO_4 batteries. This process can achieve a recovery efficiency of up to 80%. Here are the steps involved in the process:

Recovery Process and Steps of Cathode Materials

Aluminium foil, being an amphoteric metal, is dissolved in a NaOH alkali solution to form NaAlO_2 , which enters the solution. After filtration, the filtrate is neutralized with sulphuric acid and precipitated to obtain Al(OH)_3 . When the pH is above 9.0, most of the aluminium precipitates, and the obtained Al(OH)_3 achieves chemical purity after analysis.

The filter residue is dissolved with sulphuric acid and hydrogen peroxide. This process allows lithium iron phosphate to enter the solution in the form of $\text{Fe}_2(\text{SO}_4)_3$ and Li_2SO_4 , separating it from carbon black and carbon coating on the lithium iron phosphate surface. After filtration and separation, the pH of the filtrate is adjusted with NaOH and ammonia water. Iron is first precipitated with Fe(OH)_3 , and then the remaining solution is precipitated with saturated Na_2CO_3 solution at 90°C .

Since FePO_4 is slightly soluble in nitric acid, the filter residue is dissolved with nitric acid and hydrogen peroxide. This process directly precipitates FePO_4 and separates impurities like carbon black from the acid solution. It also leaches Fe(OH)_3 from the filter residue and precipitates Li_2CO_3 with saturated Na_2CO_3 solution at 90°C .

Recovery of Anode Materials

The recovery process for anode materials is relatively straightforward. Following the separation of the anode plates, the purity of copper can exceed 99%. This high-purity copper can then undergo further refining to produce electrolytic copper.

Recovery of Diaphragm

The diaphragm material is mainly harmless and has no recycling value.

List of Recycling Equipment

Automatic dismantling machine, pulverize, wet gold pool, etc.

ENVIRONMENTAL DISPOSAL

Used batteries can not be disposed of as household waste. You are obliged to handle waste batteries, such as removal of privacy on product, and return them to designated or authorized recovery point according to applicable regulations and standards on waste battery disposal.



NOTICE

- Do not dispose of batteries and rechargeable batteries as domestic waste! You are legally obliged to return used batteries and rechargeable batteries.
- Waste batteries may contain pollutants that can damage the environment or your health if improperly stored or handled.
- Batteries also contain iron, lithium and other important raw materials, which can be recycled.



Li-ion

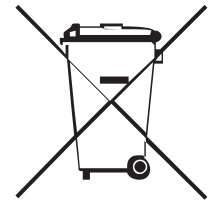
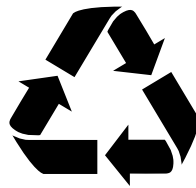

For more information, please visit sunsynk.org

Do not dispose of batteries as household waste!

TRANSPORTATION REQUIREMENTS

Transport battery products immediately after packaging using cars, trains, or ships. During transportation, avoid exposing the packaging to severe vibration, impact, or compression, as well as direct sunlight or rain.

Always ensure compliance with local, national, and international regulations before transporting Lithium Iron Phosphate batteries. Note that the transport of end-of-life, damaged, or recalled batteries may be restricted or prohibited in some cases.

The transport of Li-Ion batteries is classified under hazard class UN3480, class 9, falling into packaging group PI965 Section I for transport by water, air, or land.

For transportation of lithium-ion batteries assigned to Class 9, use Class 9 Miscellaneous Dangerous Goods and UN Identification labels. Refer to relevant transportation documents for further guidance.





Contact Us

Call +44 151 832 4300 **Email** sales@sunsynk.com **Website** www.sunsynk.com

- Address**
- HK** Room 702-704, 7/F Texwood Plaza, 6 How Ming Street, Kwun Tong, Kowloon, Hong Kong
 - UK** Sunsynk UK Ltd, 17 Turnstone Business Park, Mulberry Avenue, Widnes, Cheshire, WA8 0WN
 - SA** Stand 375, Northland Business Park, Angus Crecent Road, Hoogland, Randburg, Johannesburg
 - NL** Sunsynk NL BV, Henri Wijnmalenweg 8, 5657 EP Eindhoven, Netherlands
 - AU** Level 1, 982-988 Wellington Street, West Perth WA 6005, Australia
 - ES** Tafetana, 32 P.I. Las Andoriñas 38639 Las Chafiras Santa Cruz de Tenerife
 - US** 100 S. Ashley Drive, Suite 600, Tampa, Florida, 33602, United States of America