



# Sunsynk Elite HYB 1P IP65



## USER MANUAL

SS-3.6kW-ELITE-HYB-1P-IP65-00  
SS-5kW-ELITE-HYB-1P-IP65-00  
SS-7kW-ELITE-HYB-1P-IP65-00

[www.sunsynk.com](http://www.sunsynk.com)  
[sales@sunsynk.com](mailto:sales@sunsynk.com)  
[customerservices@sunsynk.com](mailto:customerservices@sunsynk.com)

# Table of Contents

---

<b>LEGAL INFORMATION</b>	<b>3</b>	Battery Setup Page	50
Warning Notice System	3	Generator & Battery Charge Page	51
Qualified Personnel	3	Battery Discharge Page	54
Proper Use of Sunsynk Products	3	Setting Up a Lithium Battery	55
Warranty	4	System Work Mode Setup Menu	57
Trademarks	4	Grid Supply Page	60
Disclaimer of Liability	4	Advanced Functions	65
Retention of This Manual	4	Solar Power Generated	72
		Grid Power	73
		Advanced Settings for Auxiliary Load	74
<b>SAFETY</b>	<b>4</b>	<b>OPERATING MODES</b>	<b>76</b>
General Safety	4	Mode I: Basic	76
Symbols/Safety Signs	5	Mode II: With Generator	76
Safety Instructions	7	Mode III: With Aux Load	77
		Mode IV: AC Couple	77
<b>PRODUCT INTRODUCTION</b>	<b>9</b>	<b>FAULT CODES</b>	<b>79</b>
Product Overview	9	<b>INVERTER MONITORING</b>	<b>83</b>
Product Size	10	Data Logger Installation	83
Product Features	10	Connecting to Wi-Fi	83
Basic System Architecture	11	Network Cable	84
		Registration	85
<b>TECHNICAL SPECIFICATIONS</b>	<b>12</b>	Requesting User Level Access Change	85
Battery Pack Accessories	13	Creating a Plant	86
		Adding a Device	88
<b>INSTALLATION</b>	<b>15</b>	Editing a Plant	88
Parts List	15	Plant Overview	89
Product Handling Requirements	16	Inverter Management	92
Installation Tools	17	<b>COMMISSIONING</b>	<b>95</b>
Selecting the Mounting Area	17	Start-Up / Shutdown Procedure	95
Battery Connection	19	Inverter Commissioning Info	95
Battery Temperature Sensor Connection	28	GDFI Fault	96
Grid, Load, and Generator Connections	29	<b>MAINTENANCE</b>	<b>96</b>
PV Connection	33	<b>APPENDIX A</b>	<b>97</b>
CT Coil Connection	34	<b>APPENDIX B</b>	<b>97</b>
Meter Connection	35	<b>APPENDIX C</b>	<b>97</b>
Earth Connection (MANDATORY)	36	<b>APPENDIX D</b>	<b>98</b>
Wiring System for Inverter	38	<b>APPENDIX E</b>	<b>98</b>
Typical Application of Diesel Generator	39		
Single-Phase Parallel Connection	40		
Three-Phase Parallel Inverter	41		
<b>OPERATION</b>	<b>42</b>		
Switching ON/OFF	42		
Display	42		
LCD Operation Flow Chart	43		
Home Page	44		
Status Page	44		
System Flow Page	46		
Setup Page	47		
Basic Setup	47		

# LEGAL INFORMATION

---

## Warning Notice System

This manual includes important safety warnings that help ensure your safety and prevent damage to the equipment. These warnings are clearly identified with symbols, which are categorised according to the level of risk associated with each potential hazard. It is essential to read and adhere to these warnings carefully.



### DANGER

Indicates an immediate hazard that, if not avoided, will result in serious injury or death. This is the highest level of risk.



### WARNING

Indicates a potential hazard that could result in serious injury or death if not avoided. It is slightly less severe than "DANGER".



### CAUTION

Highlights a potential hazard that could cause minor injuries or property damage if not avoided.



### NOTICE

Provides helpful information that does not indicate any hazard.

## Qualified Personnel

The Sunsynk Elite 1P described in this manual must only be installed, operated, and maintained by qualified personnel. Qualified personnel are individuals who have received formal training in electrical systems and photovoltaic (PV) installations. They must be familiar with local electrical codes and regulations and capable of identifying potential risks associated with handling high-voltage equipment.

To ensure safe and efficient installation, Sunsynk strongly recommends engaging an installer approved by Sunsynk. These installers undergo specific training on Sunsynk products, ensuring they possess the necessary knowledge for secure and optimal installation, commissioning, and operation.

Improper installation or operation of the Sunsynk Elite 1P by unqualified personnel may lead to personal injury, property damage, or voiding of the warranty.



### WARNING

- Always use only components and accessories that are recommended or approved by Sunsynk.
- Follow all procedures outlined in this manual for transport, storage, installation, commissioning, operation, and maintenance.
- Ensure compliance with local and national safety codes and regulations.
- Operate the product only within the specified environmental conditions as outlined in this manual.

## Proper Use of Sunsynk Products

The Sunsynk Elite 1P is designed for use in energy storage and management in photovoltaic systems. To ensure safe and reliable operation, it is imperative to follow the instructions provided in this manual. Failure to do so may lead to unsafe operation, product damage, or invalidation of the warranty.

# Warranty

For warranty details, please refer to the Warranty Statement supplied by Sunsynk.

Under our company's guidance, customers may return products for maintenance or replacement of equivalent value. Customers are responsible for shipping and associated costs. Any replaced or repaired product retains the remaining warranty period. If a product or component is replaced by the company during the warranty period, ownership rights of the replacement belong to the company.

Factory warranty does not cover damages resulting from:

- Transportation mishaps
- Incorrect installation or commissioning
- Failure to follow operation, installation, or maintenance instructions
- Attempts to modify, alter, or repair products
- Incorrect usage or operation
- Inadequate equipment ventilation
- Non-compliance with safety standards or regulations
- Natural disasters or force majeure (e.g., floods, lightning, overvoltage, storms, fires, etc.)

Normal wear or minor failures that do not affect product functionality are not considered defects. External scratches, stains, or mechanical wear do not indicate product defects.

# Trademarks

All names and logos identified in this document are the property of Sunsynk. Unauthorised use of Sunsynk trademarks is strictly prohibited. All other trademarks mentioned remain the property of their respective owners.

# Disclaimer of Liability

This document is the property of Sunsynk. Any reproduction, modification, or distribution of this manual without prior written consent from Sunsynk is strictly prohibited.

The content of this manual has been thoroughly reviewed for accuracy and is consistent with the product described. However, due to ongoing product improvements and updates, Sunsynk cannot guarantee complete consistency. Any necessary corrections or updates will be included in subsequent editions of this manual.

# Retention of This Manual

This manual contains essential information for the assembly, installation, commissioning, and maintenance of the Sunsynk Elite 1P. It must be retained for future reference and made accessible to all qualified personnel involved in the operation and maintenance of this product.

# SAFETY











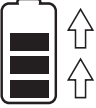

---

## General Safety

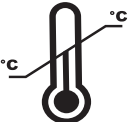
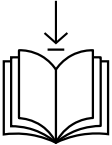
- This device must be used only as described in this manual and in compliance with all local, regional, and national laws and regulations. Ensure that installation, operation, maintenance, and repair are only performed by qualified personnel who have read and fully understood this manual. The manual should be passed to any third party who handles the device.
- DO NOT allow minors, untrained personnel, or individuals with physical or mental impairments to operate or maintain this device. Only trained individuals should interact with the device during installation, operation, or maintenance. If untrained individuals are near the device during operation, they must be informed of potential hazards and given proper instructions to avoid injury.
- Periodically inspect the device for any signs of damage or wear. Always ensure that all connections are secure and that there are no exposed wires or components that may pose a risk of electric shock.

# Symbols/Safety Signs

Symbol	Description	Symbol	Description
	Risk of danger.		Warning: Hot surface.
	Risk of electric shock. DO NOT touch the terminal or remove the shell within 5 minutes after disconnecting all power.		The battery is heavy and can cause injury if not handled safely.
	This product's batteries contain an explosive, self-reactive material that could blow up when heated.		Do not disassemble or alter the battery in any way. Do not strike or puncture the battery.
	Do not place near open fire or incinerate. Do not use near heaters or hot temperature sources.		ONLY qualified personnel should install or perform maintenance work on the units.
	Be careful when touching the inverter. It is an electrical product with risk of electric shock and heating.		Warranty void if seal is broken.
	Do not step, stand, or climb on this surface.		Avoid unsuitable shoes for installing and operating the inverter.
	Do not step or put any objects onto the battery.		Do not drop, deform, or impact the battery.
	Single-phase.		Three-phase.
	Protective conductor terminal or earth ground terminal.		Rechargeable.
	Do not submerge the battery in water or expose it to moisture or liquid.		Keep out of reach of children, animals, and insects.
	Do not expose the product to sunlight.		Inverter DC to AC.
	Li-ion battery.		Net weight in kilograms.
	<b>BATTERY INPUT</b> Battery Discharge Voltage, Battery Discharge Current, Input Voltage Type, Battery Discharge Power.		<b>PV INPUT</b> PV Input Voltage, Number of MPPT's, MPPT Input Current & Max PV ISC.

Symbol	Description	Symbol	Description
	Direct current.		Indicates that this product is recyclable.
	<b>AC OUTPUT</b> Output Voltage, Input Voltage Type, Ac Output Rated Current, Max AC Current, Output Frequency, Max AC ISC, Power Factor & AC Output Rated Power.		<b>CONTINUOUS OUTPUT CURRENT</b> Maximum Continuous Output Current, Output Frequency and Voltage, & AUX (programmable AC output on battery SOC).
	Charging.		Discharging.
	Follow the indicated temperatures.		<b>TEMPERATURE</b> Ambient, Min & Max.
	<b>MANUAL DOWNLOAD</b> Download the latest version of the instruction manual by scanning the QR code.		<b>WARRANTY REGISTRATION</b> Scan the QR code to access our website and sign up for the manufacturer's warranty.
	Do not dispose the device, accessories, and packaging with regular waste. Follow local ordinances or contact the manufacturer for disposal guidance.		Refer to the operating instructions. Contact the supplier within 24 hours if there is anything wrong. In case of leakage contact with eyes or skin, immediately clean with water and seek help from a doctor.
	CE mark is attached to the solar inverter to verify that the unit follows the provisions of the European Low Voltage and EMC Directives.		The UKCA marking is used for products placed on the market in Great Britain (England, Scotland and Wales). The UKCA marking applies to most products for which the CE marking could be used.

# Safety Instructions

This section provides essential safety and operational guidelines. Please read carefully and keep this manual for future reference.



## DANGER

### Fatal Electric Shock Hazard

- DO NOT DISASSEMBLE the inverter. Improper reassembly may result in electric shock or fire.
- Disconnect all wires (AC and DC) before attempting any maintenance or cleaning. Turning off the unit will not eliminate this risk.
- Strictly follow the installation procedure when disconnecting AC or DC terminals. Never cause the AC output and DC input to be short-circuited.
- After turning off the AC and DC circuits, maintenance personnel must wait for 5 minutes for the power to be completely discharged before starting work.

### Grounding Requirement

- This inverter must be connected to a permanent grounded wiring system. Ensure compliance with local requirements and regulations.
- The DC input terminals of the inverter must not be grounded.



## WARNING

### Installation and Personnel

- Only qualified personnel can install this device with the battery.

### Risk of Fire/Explosion & Short-Circuit

- Be extremely cautious when working with metal tools on or around batteries. Dropping a tool may cause a spark or short circuit in batteries or other electrical parts, potentially causing an explosion.
- A discharged battery needs to be recharged within 48 hours.
- Never charge a frozen battery.

### Overcurrent/Overload

- It is vital for system safety and efficient operation to use the appropriate cable size for AC input/output and PV connections, as specified in the manual.

### Residual Current Detection (RCD)

- The inverter has a built-in leakage current detection circuit. If an external RCD is connected, its operating current must be 300 mA or higher; otherwise, the inverter may not work properly.

### PV Connection & Surges

- To avoid malfunction, do not connect PV modules with possible current leakage to the inverter (e.g., grounded PV modules).
- It is required to use a PV junction box with surge protection (Type II DC).



## CAUTION

### Handling and Lifting

- Remember that the battery is heavy! Be careful when lifting it from the package. The battery module must be installed by at least two persons using movable handles.
- Move the inverter by holding the handles on it. Do not move the inverter by holding the terminals.
- The inverter casing is a surface high temperature hazard. Do not touch the inverter case.

### Installation Environment (Inverter & Battery)

- The inverter is designed for outdoor use (IP65), but avoid direct sunlight, rain exposure, and snow laying up during installation and operation.
- Install the battery in a clean, flat place, with no direct sunlight, away from water and fire sources, and at a suitable temperature.
- Placing the inverter directly on a hard ground may cause damage to its metal enclosure. Protective materials (e.g., sponge pad or foam cushion) should be placed underneath.

### Electrical Connections

- Ensure the AC output terminals are connected to the correct wires (Load, Grid, Gen), and pay attention to L, N, and PE polarities.

### Appliance Protection

- Appliances like air conditioners require a time delay to restart (2-3 minutes) after a short power shortage. Check if your appliance is equipped with a time-delay function to prevent damage.



## NOTICE

### General Information

- Read the manual and related documents before performing any operation. Keep the documents stored carefully and available at all times.
- The latest manual can be acquired via the manufacturer's service email.

### Installation Restrictions

- Do not install the inverter higher than an altitude of about 2000 meters above sea level.
- Installation clearance should be maintained:  $\geq 200$  mm (top) and  $\geq 600$  mm (sides) from walls/obstructions.

### Battery System Details (LiFePO4)

- The battery chemistry is Lithium-ion (LiFePO4).
- The battery's operating voltage range is 40 V to 60 V.
- The charging strategy for the Li-Ion battery is Self-adaption to BMS.

### Operational Protection Features

- The equipment is fitted with AC Output Overcurrent Protection, AC Output Overvoltage Protection, DC reverse polarity protection, Thermal Protection, and Anti-islanding protection.

### End-of-Life Disposal

- Electrical devices must be disposed of according to local electronic waste disposal regulations. Do not dispose of this product with household waste.

# PRODUCT INTRODUCTION

This is an All-in-one energy storage system integrated with 3.6/5/7kW hybrid inverters and energy storage batteries. Modular stacked design, easy installation, easy expansion, Lithium iron phosphate battery, safe and reliable.

This multifunctional inverter combines the functions of an inverter, solar charger and battery charger to offer uninterruptible power support with a portable size. Its comprehensive LCD display offers user-configurable and easily accessible button operations such as battery charging, AC/solar charging, and acceptable input voltage based on different applications.

## Product Overview

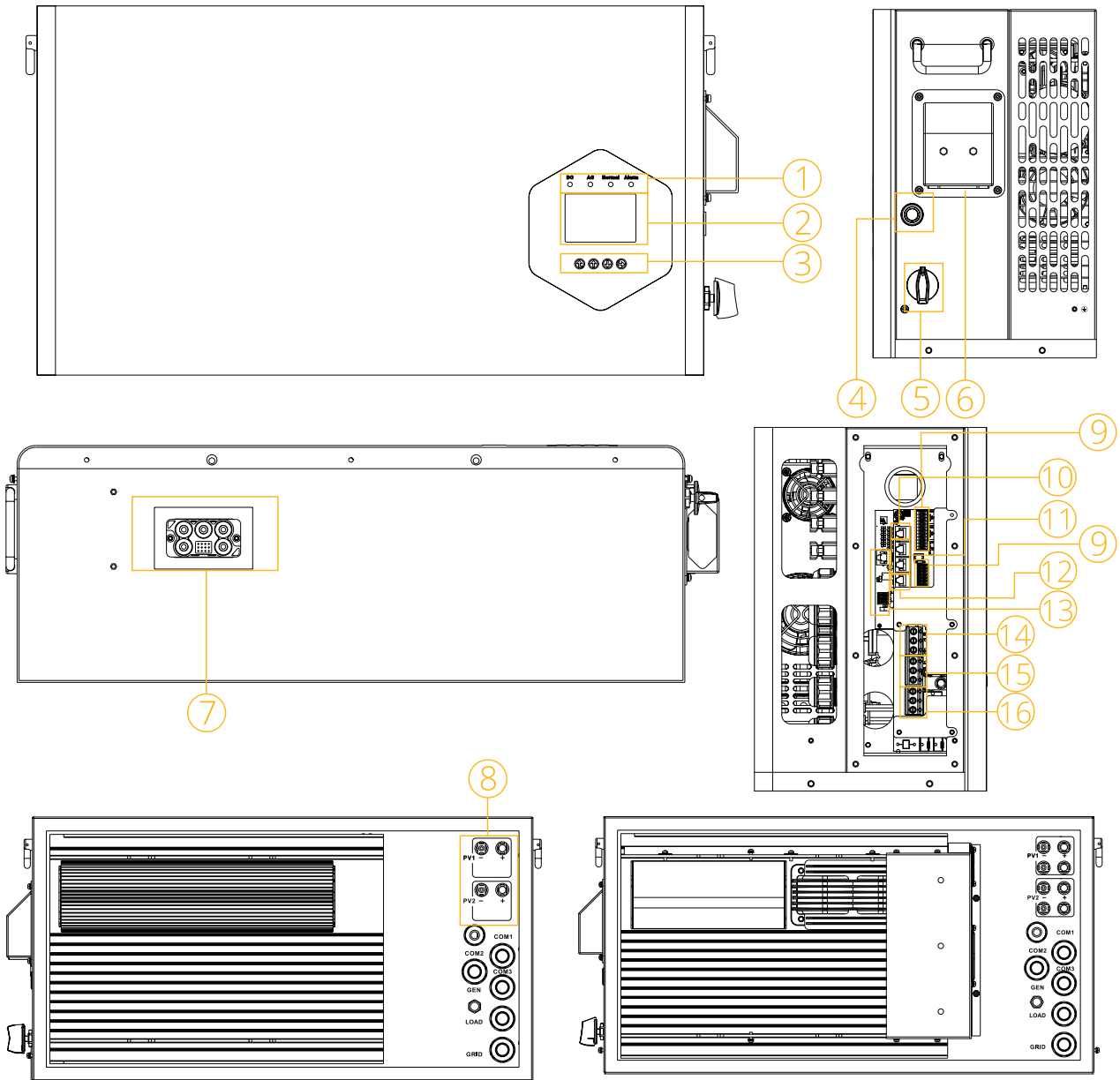

**SS-(3.6/5)kW-ELITE-HYB-1P-IP65-00**

**SS-(7)kW-ELITE-HYB-1P-IP65-00**

- |                        |                             |                       |
|------------------------|-----------------------------|-----------------------|
| 1. Inverter Indicators | 7. Battery Input Connectors | 13. DRMs and DI Ports |
| 2. LCD Display         | 8. PV Input with two MPPT   | 14. Generator Port    |
| 3. Function Buttons    | 9. Function Port            | 15. Load Port         |
| 4. Power On/Off Button | 10. RS485/Meter Port        | 16. Grid Port         |
| 5. DC Switch           | 11. Parallel Port           |                       |
| 6. WiFi Interface      | 12. BMS 485/CAN Port        |                       |

## Product Size

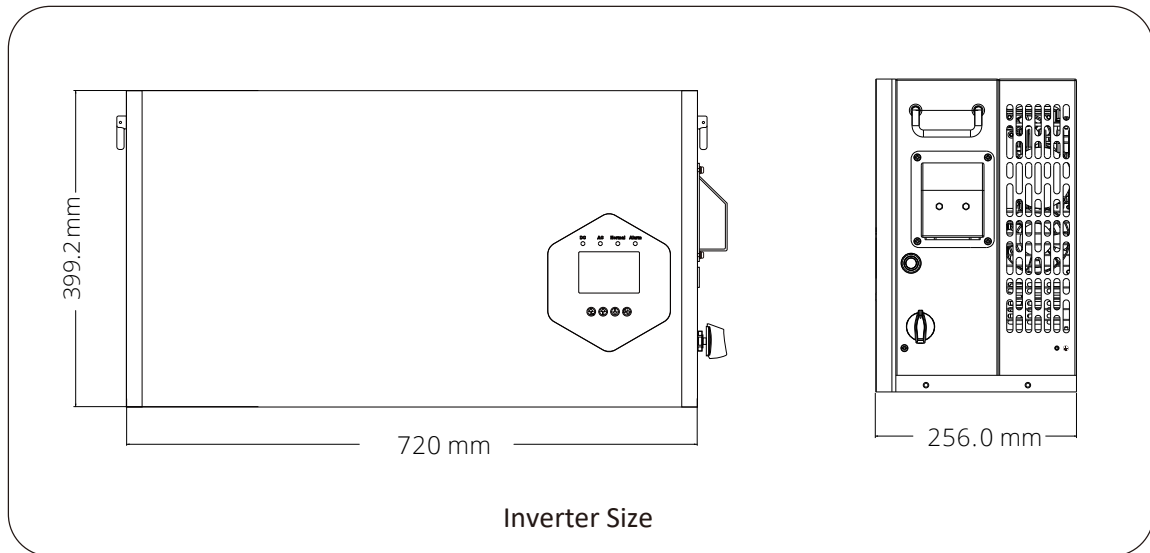

## Product Features

### INTERACTIVE

- Easy and simple to understand display
- Supporting Wi-Fi or GSM monitoring
- Visual power flow screen
- Built-in 2 strings of MPP trackers
- Smart settable 3-stage MPPT charging for optimized battery performance
- Flat and stackable design, no wiring and extra fixing screws, quick and easy installation
- Auxiliary load function
- Parallel / multi invert function grid-tied and off-grid

### COMPATIBLE

- Compatible with main electrical grid voltages or power generators
- Compatible with wind turbines
- Self-consumption and feed-in to the grid
- Auto restart while AC is recovering
- Auto earth bond feature (Via a relay)

### CONFIGURABLE

- Fully programmable controller
- Programmable supply priority for battery or grid
- Programmable multiple operation modes: on-grid/off-grid & UPS
- Configurable battery charging - current/voltage based on applications by LCD setting
- Configurable AC / solar / generator charger priority by LCD setting

### SECURE

- Overload/over-temperature/short-circuit protection
- Smart battery charger design for optimized battery protection
- Limiting function installed to prevent excess power overflow to grid
- Fast switching time of 4ms, ensuring your energy security

## APPLICATIONS

- Marine (vessel power management)
- Power shedding (home/office/factory)
- UPS (fuel-saving systems)
- Remote locations with solar and wind generators
- Building sites
- Military locations
- Telecommunication

## Basic System Architecture

The diagram below illustrates a typical configuration of the Sunsynk Elite 1P within a complete operational system. The following key components are essential for optimal performance and energy management:

- PV Modules (Solar Panels): Capture sunlight and convert it into DC (direct current) power.
- Sunsynk Hybrid Inverter: Converts the DC power from the solar panels and battery into AC (alternating current) power for household or business use.
- Battery: Stores excess solar energy for use when sunlight is insufficient (e.g., at night or during cloudy days).
- Generator or Utility Grid: Provides power to the system when solar energy and stored battery power are unavailable. It can also serve as a backup power source.
- Grid-Connected Load (AC Loads): Powers everyday household or business appliances such as lights, refrigerators, and other electrical devices.
- Backup Load: Ensures essential appliances (e.g., medical equipment, emergency lighting) continue to operate during power outages.
- Smart Load: Enables efficient energy use by intelligently prioritising or controlling the use of appliances based on available power.

In addition, the system integrates the following features for flexibility and smart operation:

- Wi-Fi/GPRS: Allows remote monitoring of the inverter's performance via a mobile app or cloud-based services.
- Automatic Transfer Switch (ATS): Automatically switches between power sources (e.g., grid, generator, and battery) to ensure a continuous power supply without interruption.

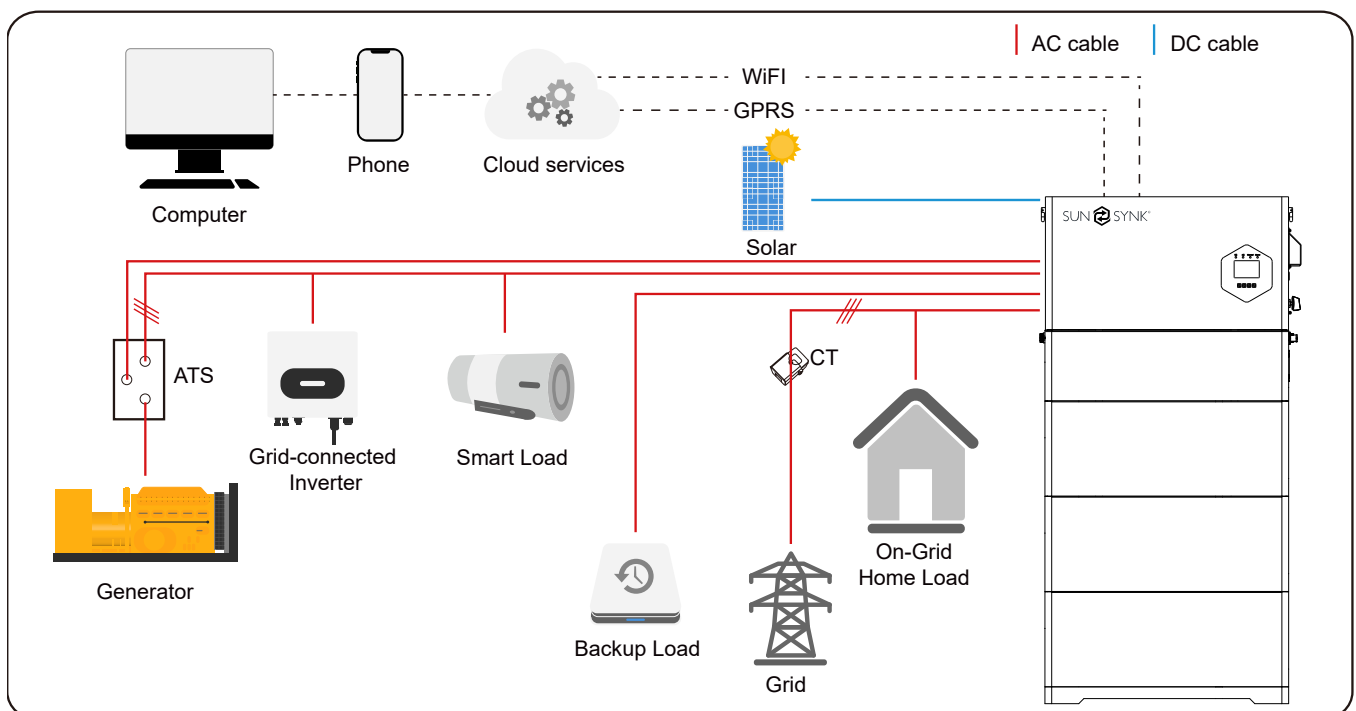

# TECHNICAL SPECIFICATIONS



## NOTICE

Approvals and certification are subject to change without prior notice. Please confirm the current status with Sunsynk before placing an order.

Model	SS-3.6kW-ELITE-HYB-1P-IP65-00	SS-5kW-ELITE-HYB-1P-IP65-00	SS-7kW-ELITE-HYB-1P-IP65-00
<b>Battery Input Data</b>			
Battery Type	LiFePO4		
Battery Voltage	40-60V		
Max. Charging Current	90A	120A	175A
Max. Discharging Current	90A	120A	175A
Charging Strategy for Li-Ion Battery	Self-Adaption to BMS		
Number of Battery Input	1		
Max. Number of Stacked Batteries	6		
<b>PV String Input Data</b>			
Max. PV Access Power	7200W	10000W	14000W
Max. PV Input Power	5760W	8000W	11200W
Max. PV Input Voltage	500V		
Start-Up Voltage	125V		
PV Input Voltage Range	125-500V		
MPPT Voltage Range	150-425V		
Full Load MPPT Voltage Range	300-425V		200-425V
Rated PV Input Voltage	370V		
Max. Operating PV Input Current	18+18A		32+32A
Max. Input Short-Circuit Current	27+27A		48+48A
No. of MPPT Trackers/ No. of String MPPT Tracker	2/1+1		2/2+2
Max. Inverter Backfeed Current to the Array	0		
<b>AC Input/Output Data</b>			
Rated AC Input/Output Active Power	3600W	5000W	7000W
Max. AC Input/Output Apparent Power	3960VA	5500VA	7700VA
Peak Power (Off-Grid)	2 Times of Rated Power, 10s		
Rated AC Input/Output Current	15.7A	21.8A	30.5A
Max. AC Input/Output Current	17.2A	23.9A	33.5A
Max. Continuous AC Passthrough (Grid to Load)	35A		50A
Max. Output Fault Current	31.4A	43.4A	61A
Max. Output Overcurrent Protection	80A		140A
Rated Input/Output Voltage/Range	230V 0.85Un-1.1Un		
Grid Connection Form	L+N+PE		
Rated Input/Output Grid Frequency/Range	50Hz/45Hz-55Hz		
Power Factor Adjustment Range	0.8 Leading to 0.8 Lagging		
Total Current Harmonic Distortion THDi	<3% (of Nominal Power)		
DC Injection Current	<0.5%In		

Model	SS-3.6kW-ELITE-HYB-1P-IP65-00	SS-5kW-ELITE-HYB-1P-IP65-00	SS-7kW-ELITE-HYB-1P-IP65-00
<b>Efficiency</b>			
Max. Efficiency	97.60%		
Euro Efficiency	96.50%		
MPPT Efficiency	>99%		
<b>Equipment Protection</b>			
Integrated	DC Polarity Reverse Connection Protection, AC Output Over-Current Protection, AC Output Over-Voltage Protection, AC Output Short Circuit Protection, Thermal Protection, Arc Fault Circuit Interrupter (AFCI) (Optional), Power Network Monitoring, Island Protection Monitoring, Earth Fault Detection, DC Input Switch, Overvoltage Load Drop Protection, Residual Current (RCD) Detection		
Anti-Islanding Protection	Yes (Active Frequency Shift)		
Surge Protection Level	TYPE II(DC), TYPE II(AC)		
<b>Interface</b>			
Display	LCD+LED		
Communication Interface	RS232, RS485, CAN		
Monitor Mode	GPRS/WIFI/Bluetooth/4G/LAN (Optional)		
PV Connection	VP-D4		
<b>General Data</b>			
Operating Temperature Range	-40 to +60°C, >45°C Derating		
Permissible Ambient Humidity	0-100%		
Permissible Altitude	2000m		
Noise	<30dB(A)		
Ingress Protection (IP) Rating	IP65		
Inverter Topology	Non-Isolated		
Over-Voltage Category	OVC II(DC), OVC III(AC)		
Cabinet Size (WxHxD)	720x399.2x256mm (Excluding Connectors & Brackets)		
Weight	31.6kg		
Warranty	See website for Warranty details		
Type of Cooling	Intelligent Air Cooling		
Grid Regulation	This product complies with ISO and its relevant norms and standards. Approvals and certifications are subject to change without notice. Please verify current status with Sunsynk before ordering.		
Safety EMC/Standard			

## Battery Pack Accessories

Model	Parts	Description
SS-5.1kWh-ELITE-BATT-1P-IP65-00 (Individual Package)	5.12kWh Battery Module (Standard Configuration)	Stackable battery module, ranging from 5.12kWh to 30.72kWh, allowing up to six 5.12kWh modules to be installed.
SS-5.1kWh-ELITE-BMS+BASE-IP65-00 (Individual Package)	Power Distribution Unit (Included)	Required to connect battery modules to the hybrid inverter. Each PDU supports up to 6 battery modules (30.72kWh).
	Base (Included)	The bottom support seat.

**SS-5.1kWh-ELITE-BATT-1P-IP65-00**



Details

5.12kWh, 720x255x300mm (WxDxH), 55kg

**SS-5.1kWh-ELITE-BMS+BASE-IP65-00**



Details

720x255x228mm (WxDxH), 15kg  
Built-In Circuit Breaker 250A 2P, 1000Vdc



Details







720x255x68mm (WxDxH), 6.5kg

# INSTALLATION

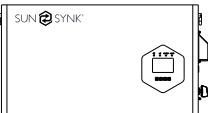
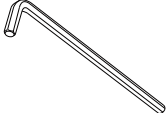

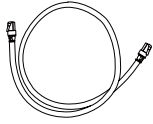
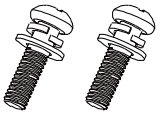
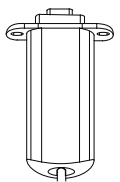
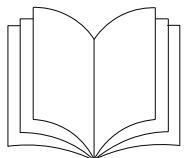
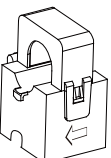
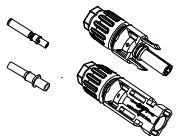
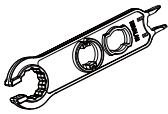
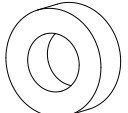

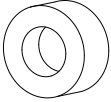
## Parts List

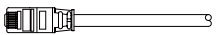
Check the equipment before installation. Please make sure nothing is damaged in the package. You should have received the items in the following package:

### Inverter Package

 Hybrid Inverter x1	 L-type Hexagon Wrench x1	 Battery Temperature Sensor x1	 Parallel Communication Cable x1	 Stainless Steel Mounting Screws M4*12 x2
 Data Logger x1	 Pamphlet x1	 Sensor Clamp x 1	 DC+/DC- Plug Connectors Including Metal Terminal xN	 Solar Photovoltaic Connector Special Spanner x1
1  Magnetic ring for Meter communication cable x1 (33×23×15mm)	2,3,4  Magnetic ring for AC wires x3 (26×16×10mm)	5  Magnetic ring x1 (31×29×19mm)	6  Magnetic ring for CT's output wire x1 (20×12.5×8mm)	 DRM connector (optional) x1

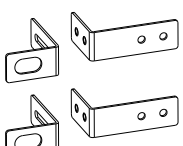
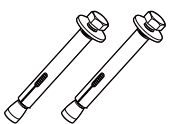
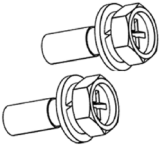
### System Power Distribute Unit Packaging Box

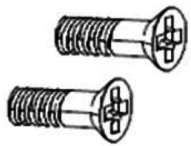
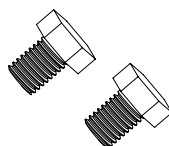
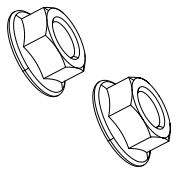
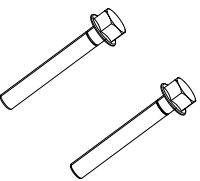
 BMS x1	 Ground wire 2m x1	 Wall fixing plate x2 sets	 Expansion screws M6*100 x2	 Wall fixing plate mounting screws M4*12 x9
 Base x1	 Retractable Rack x4	 Upper and lower fixing screws M4*6 x4	 M10*20 bolt x4	 M8*Flange nut x4
 M8*70 bolt x4				

## Li-ion Battery Pack Packaging Box

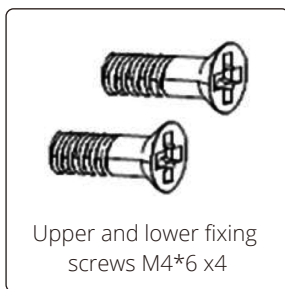
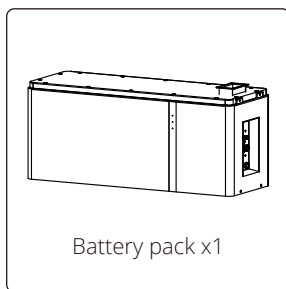

## Product Handling Requirements

Lift the inverter out of the packing box and transport it to the designated installation location.

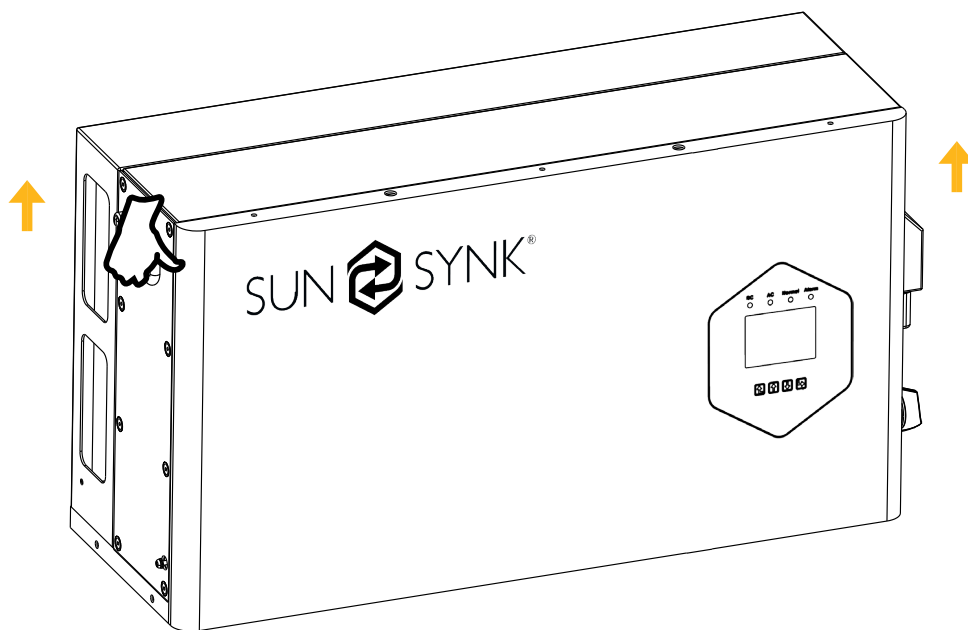

### WARNING

#### Improper handling can result in personal injury!

- Ensure an adequate number of personnel are present to lift the inverter safely, considering its weight. Installation personnel should wear protective gear, including anti-impact shoes and gloves.
- Avoid placing the inverter directly on hard ground, as this can damage its metal enclosure. Use protective materials like sponge pads or foam cushions underneath the inverter.
- Move the inverter with one or two people or utilize appropriate transport tools.
- When moving the inverter, always hold it by the handles. Do not attempt to move it by holding the terminals.

## Installation Tools

Installation tools can include the following recommended items. Additionally, utilize any other auxiliary tools available on-site.

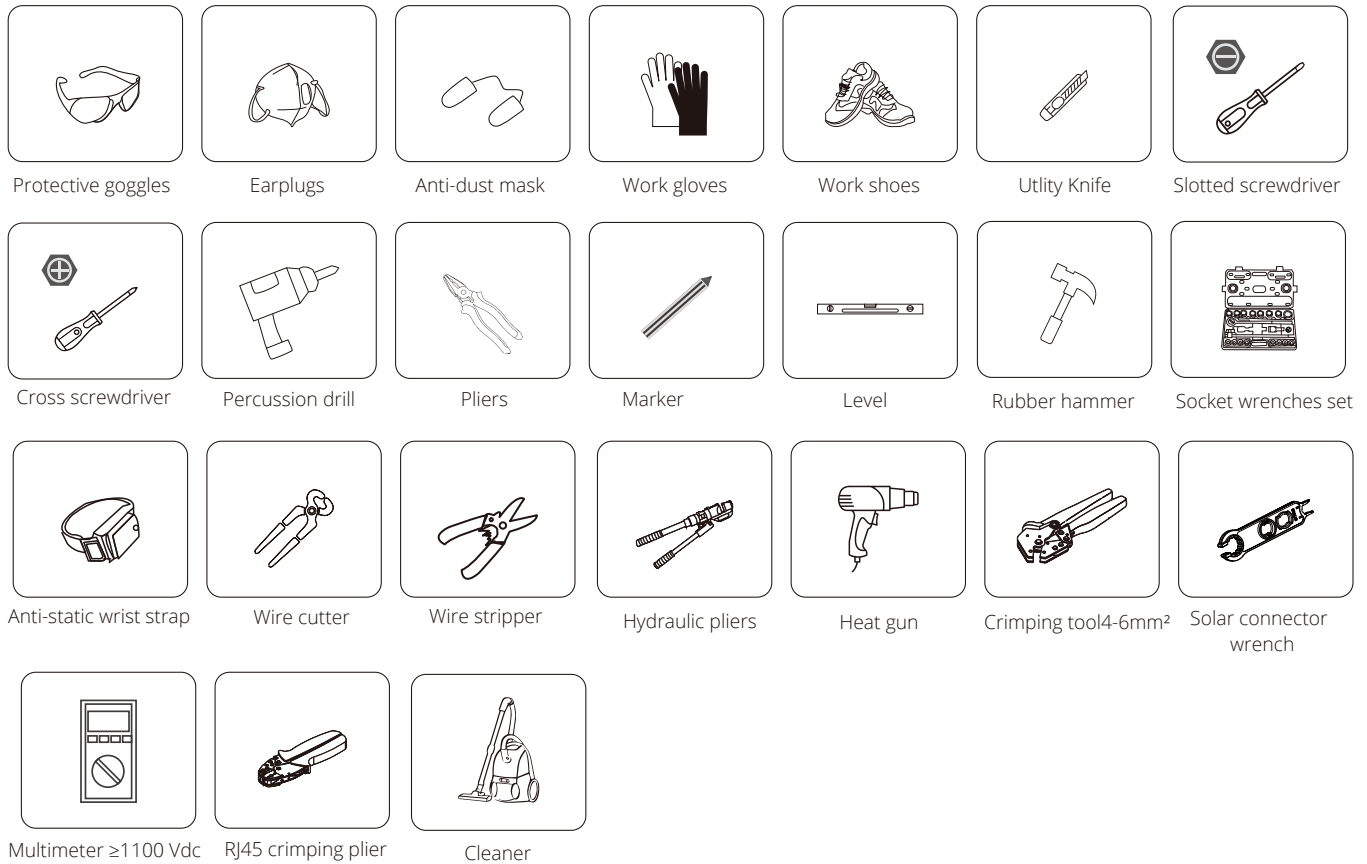

## Selecting the Mounting Area

The Sunsynk Elite 1P is rated IP65 and is suitable for outdoor installation. However, do not install the inverter in the following locations:

- Coastal or high-salt areas: Salt can corrode metal parts and allow moisture to enter the unit.
- Kitchens or oily environments: Oil mist, steam, or splashed liquids can damage plastic parts and compromise the inverter's sealing.
- Chemically active areas: Avoid areas with sulphuric gases, chlorine, acids, or alkalis, which can corrode internal copper components and reduce electrical conductivity.
- Flammable or explosive atmospheres: Do not install near areas with a risk of gas leaks, flammable dust, paint thinners, or volatile chemicals.
- Enclosed gas-prone spaces: Avoid spaces where leaked gases may collect around the inverter, as this presents a fire risk.
- Animal-exposed areas: Do not install where animals may urinate or where ammonia is present, as this can damage internal components.
- High altitude: Installation above 2,000 metres (sea level) is not recommended due to reduced cooling efficiency and potential derating.
- Excessive humidity: Do not install in environments with humidity levels above 95%.

- Poor air circulation: Ensure there is sufficient ventilation to allow for proper cooling.
- Areas exposed to direct sunlight.

Before connecting all wires, please take the metal cover off, removing the screws as shown below:

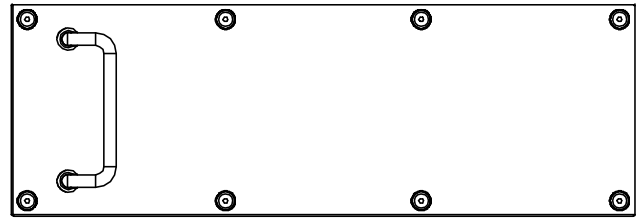
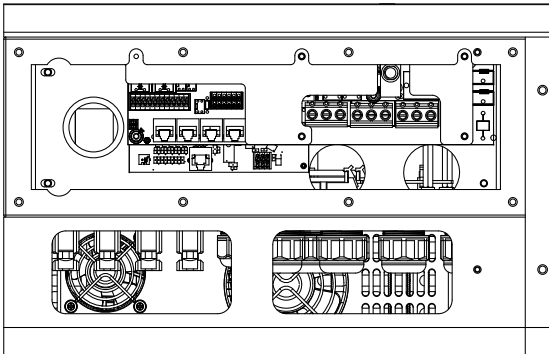

## DANGER

### Risk of Fire or Explosion

- Despite careful construction, electrical devices can cause fires, resulting in death or serious injury.
- Do not mount the system in areas containing highly flammable materials or gases.
- Do not mount the system in potentially explosive atmospheres.



## NOTICE

Avoid direct sunlight, rain, or snow accumulation during installation and operation. These environmental factors may reduce the inverter's efficiency and lifespan.

Before connecting any wires, remove the inverter's metal cover by loosening the screws, as shown in the diagram below.

## Battery Connection

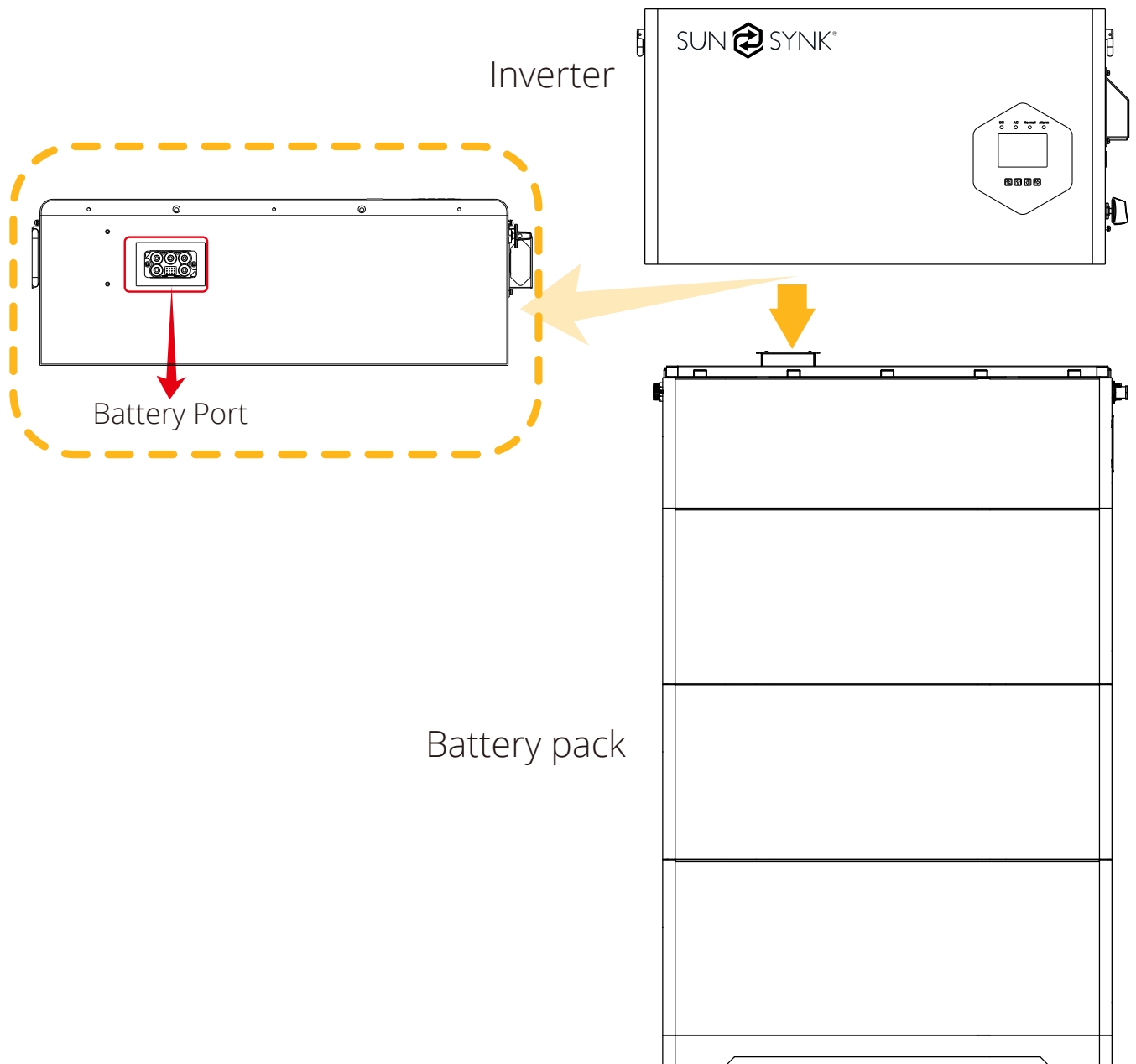

### CAUTION

#### Risk of Injury (Heavy Object)

The inverter is heavy. Please ensure that the unit is handled carefully during installation, especially when mounting or removing it from the wall. Always use proper lifting techniques and, if possible, have two people assist with the mounting process to avoid injury.

## Selection of Installation Sites

It is necessary to choose the appropriate installation location site according to the requirements. Batteries should be installed in a clean flat place with no direct sunlight, away from water and fire sources, and at a suitable temperature. The installation location is recommended to meet the size requirements of the figure below:

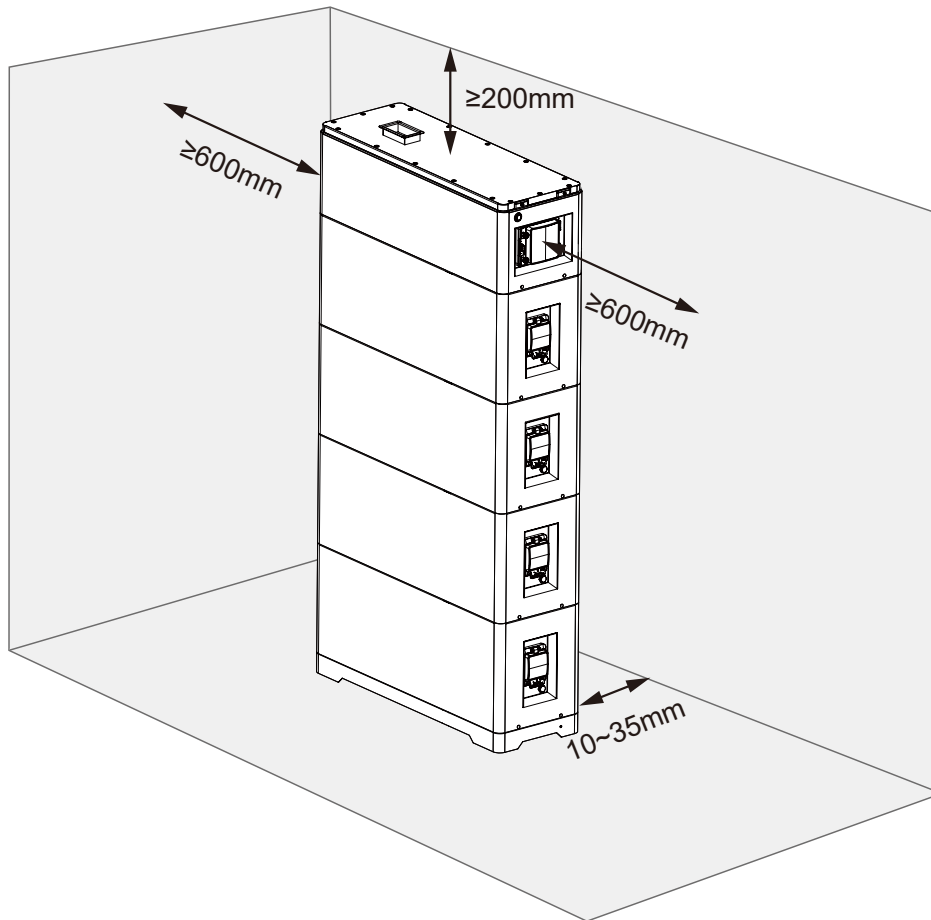

## Unpacking Order

First open the box of the **System Power Distribute Unit** packaging box, take out the base and handle, the handle is used to carry the battery module, without the handle the battery module will be difficult to remove from the battery box.

## Installation Order

1. Put the installed base and feet along the wall, and keep the distance of  $10\sim 35\text{ mm}$  between the wall and the base.

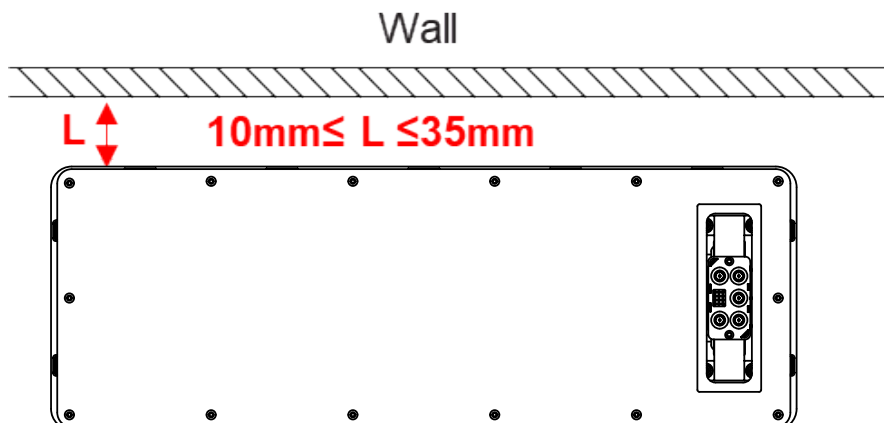

2. Open the battery box, take a battery module from the package out. Hold the handle of both batteries with your hands easy for lifting. Put one battery module on the base. Insert the plug on the base into the port on the battery. Pay attention to the direction of the module to make sure that the blind-mating connectors of the module and the base are at the same side.

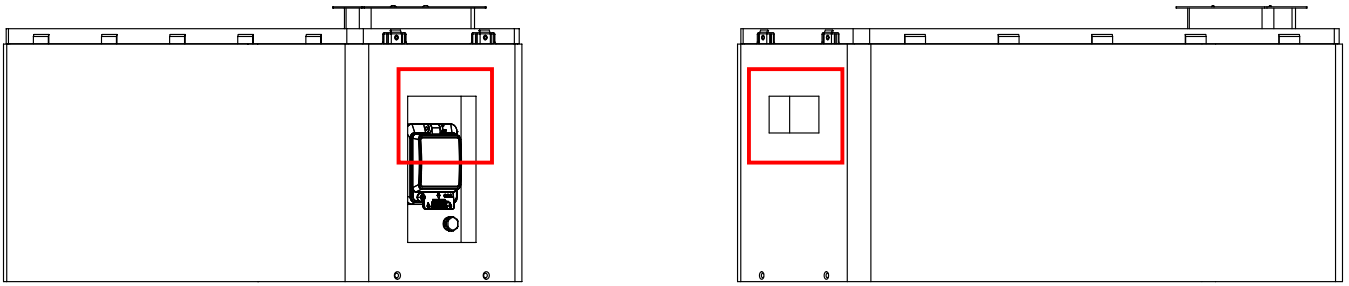

3. Repeat the operations for other battery modules.

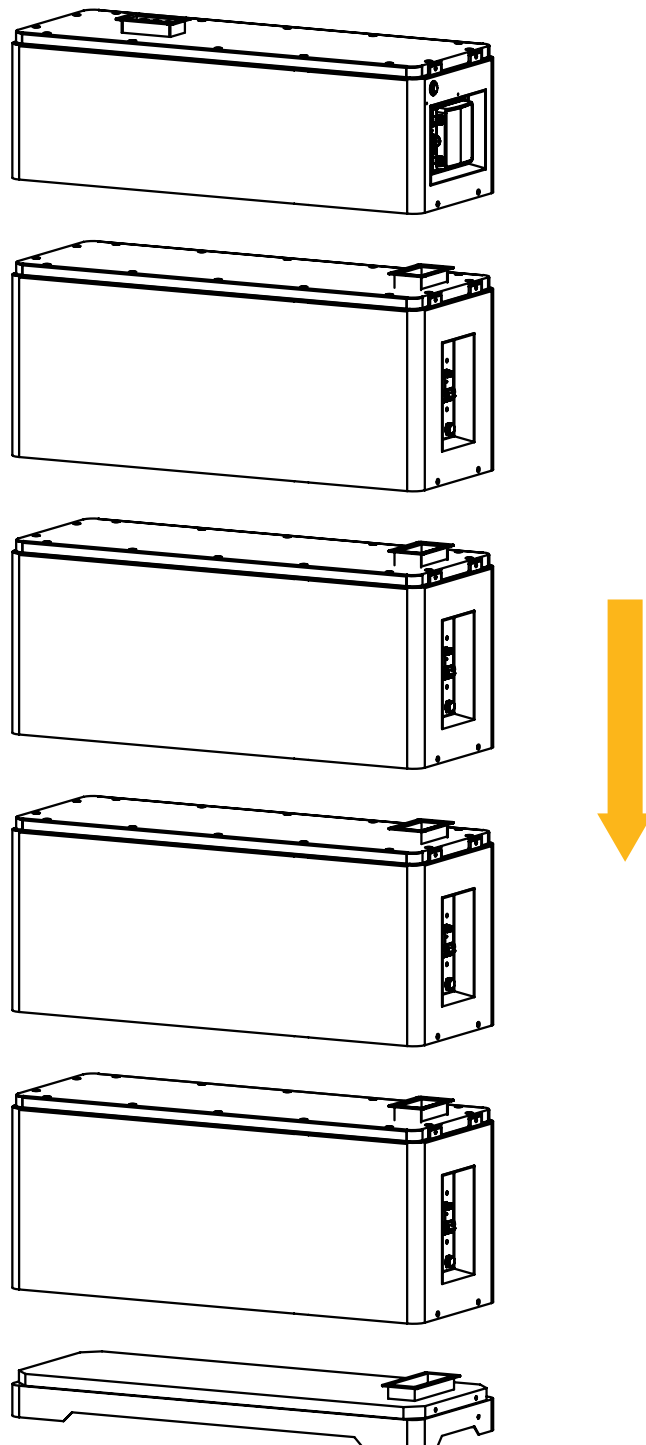

4. Install the wall fixing plate (PDU part) to the PDU. To do this, follow the instructions below to install and tighten them on the back side of PDU (torque: 2 Nm).

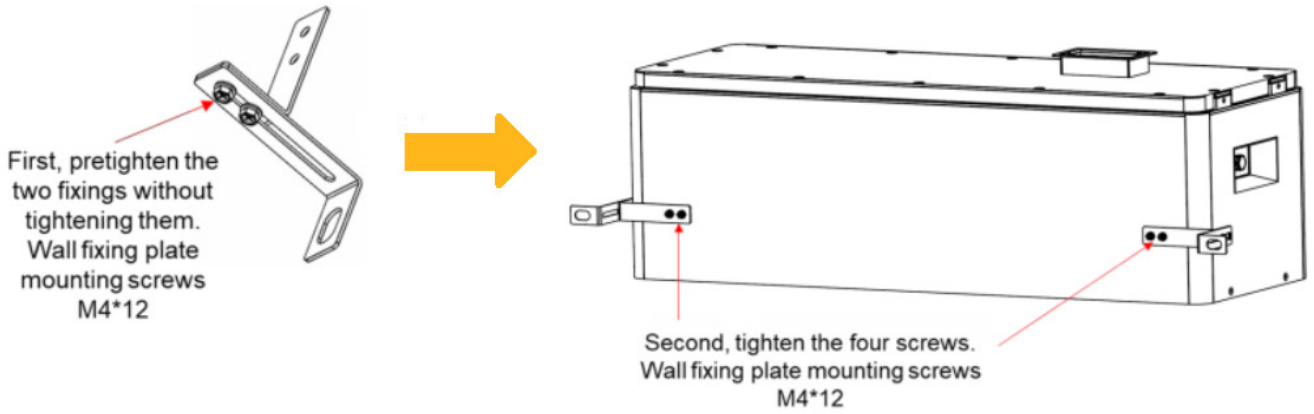

5. After all battery modules are stacked, put the PDU on top of the battery modules.
6. Fix the connection between the battery module the base, between battery modules, and between PDU and battery module with screws (M4\*6). To do this, use a Phillips screwdriver to tighten the screws through the holes on them.

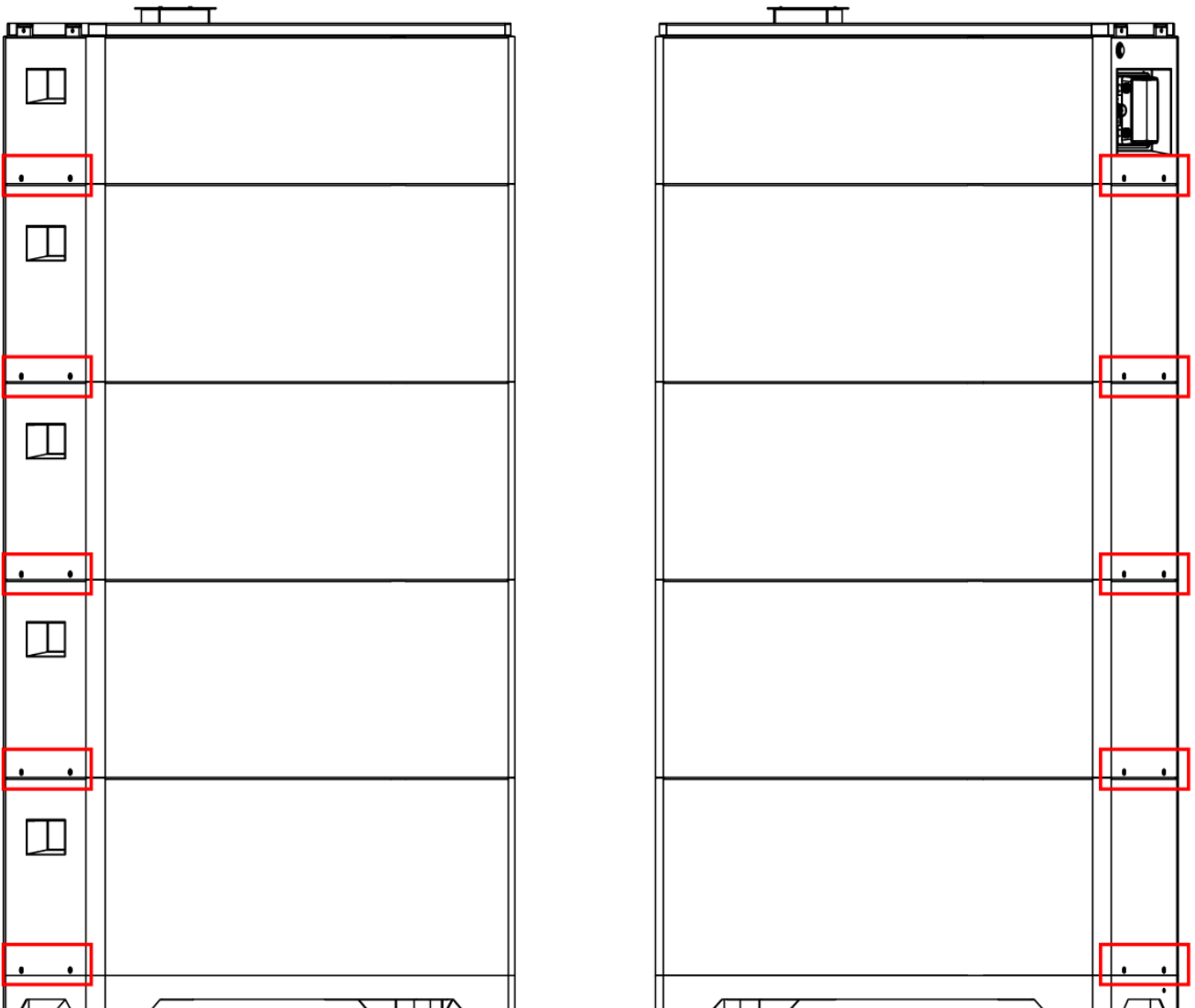

7. Hold the wall fixing plate (wall part) where it intends to be mounted on the wall and mark the position of the drill holes. Please pay attention that there may be power cables or other supply lines (e.g., gas or water) routed inside of the wall. Ensure that no lines are laid in the wall, which could be damaged when drilling holes.

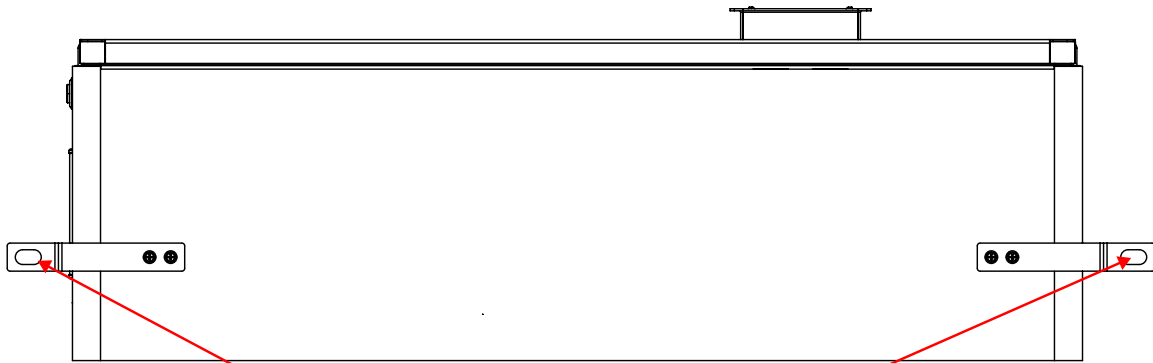

Mark the position of the drill holes

8. Set the wall fixing plate (wall part) aside and drill the marked holes. Choose the recommend drill head (10mm) to drill 2 holes on the wall, 100mm-110mm deep. Put the wall fixing plate (wall part) in front of the holes, then insert the expansion screw of M6\*100 and tighten.
9. Fix the two hangers (wall part and PDU part) with M4X12 screws, using a cylinder screwdriver (10 mm) to tighten it (torque: 2 Nm).

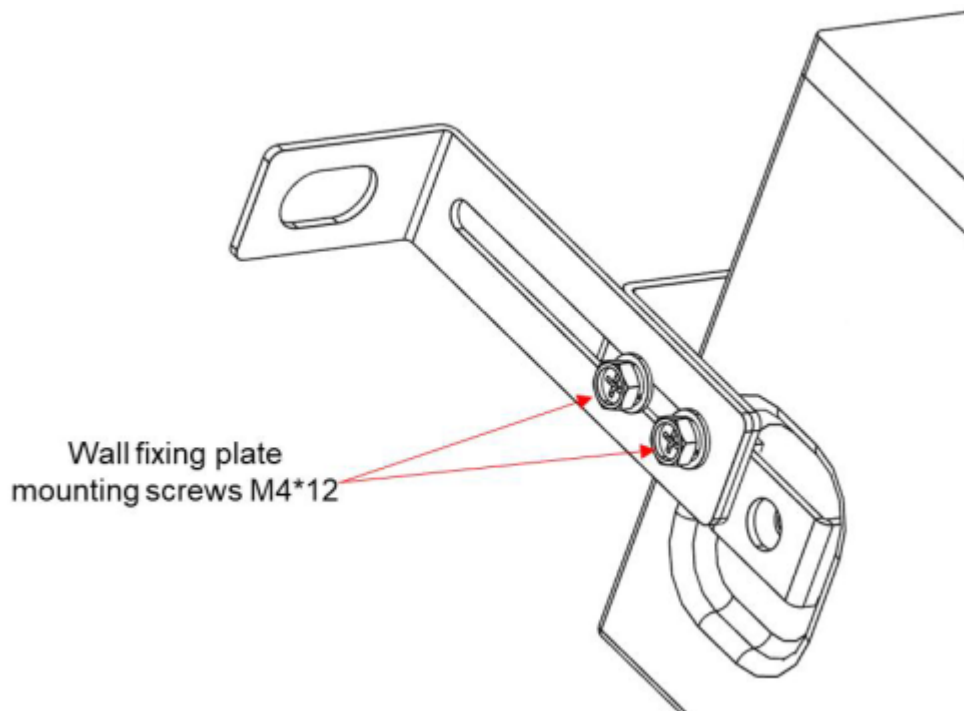

## Floor-Mounted Method

1. By rotating clockwise, the adjusting block is fixed on the base, and the length can be adjusted to 40mm.

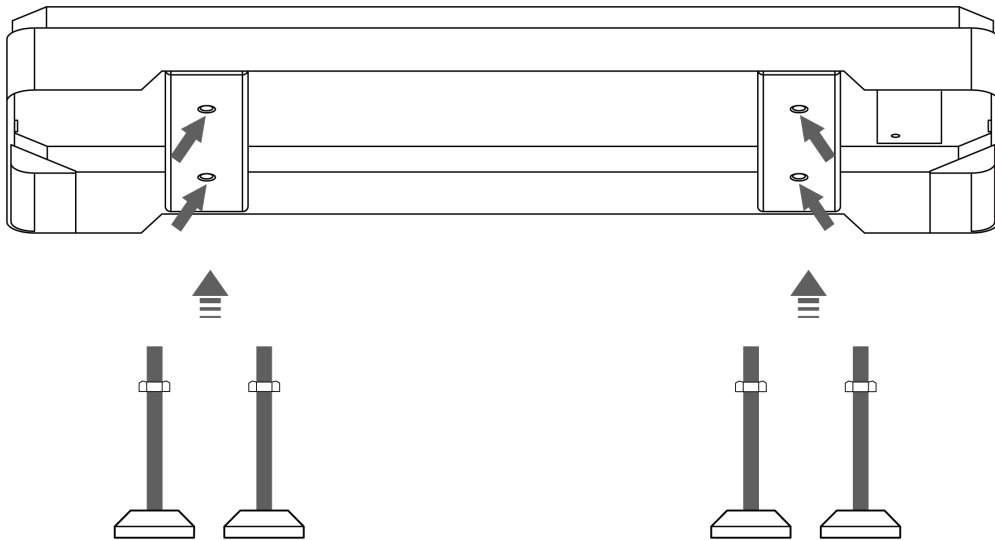

2. Adjust the height of the adjusting block by rotating it.

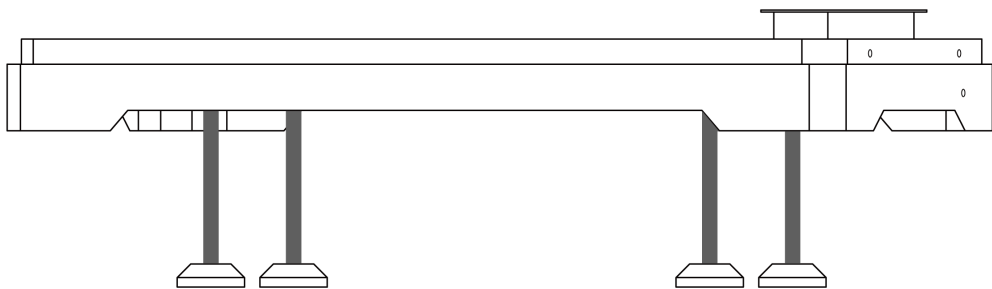

3. Stack battery packs and the PDU, and then secure with screws as mentioned in the Method 1. The quantity of stacked batteries that are regarded as one cluster, is no more than 5.

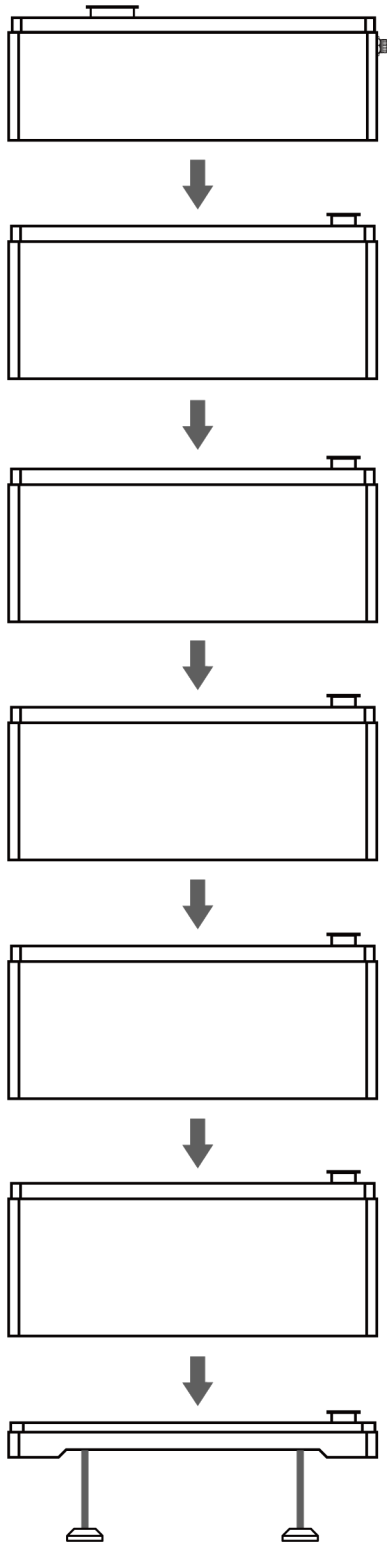

# Function Port Definition

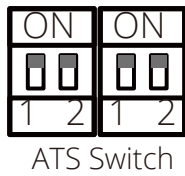

ATS Switch

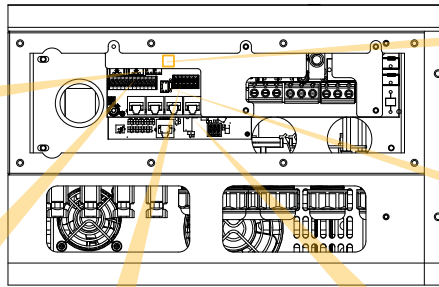

+5V Switch

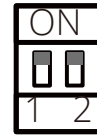

Parallel Switch

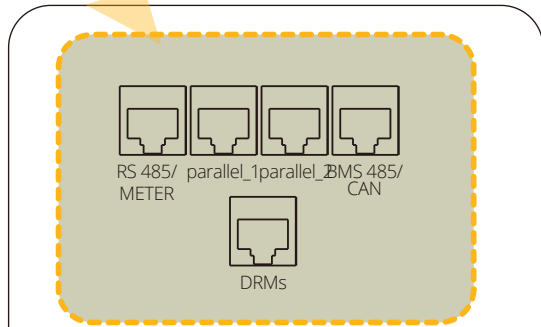
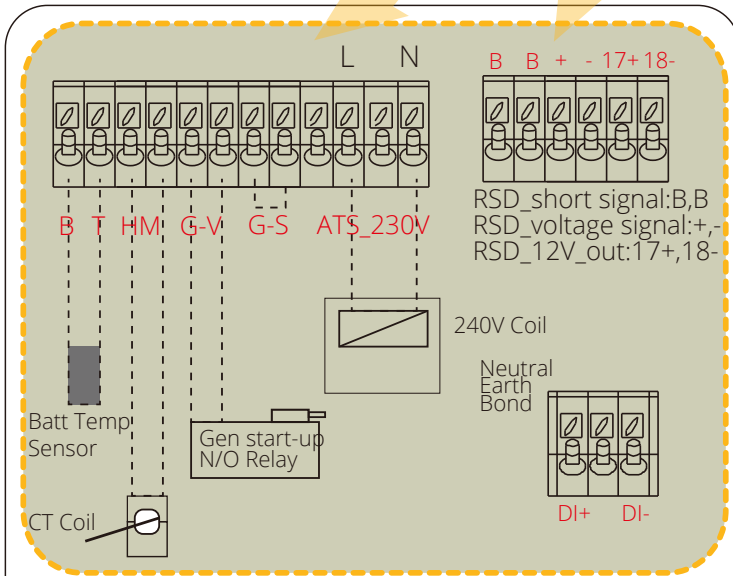

BMS 485/CAN: BMS 485 port for battery communication.

RS 485/METER: RS 485 port for energy meter communication.

Parallel 1: Parallel communication port 1 (CAN interface).

Parallel 2: Parallel communication port 2 (CAN interface).

DRMs: It is used to accept the external input signal(Digital input).

+5V Switch: For turning ON/OFF the 5V DC output of pin 3 of the meter port.

BT: Battery temperature sensor for lead acid battery.  
 HM: Current transformer for "zero export to CT" mode.  
 GV/GS: Dry contact signal for startup the diesel generator. When the "GEN signal" is active, the open contact (GV/GS) will switch on (no voltage output). If the "Signal ISLAND MODE" is ticked, the GS port will be the dry contact signal for startup the diesel generator. If "Signal ISLAND MODE" is not ticked, the GV port will be the dry contact signal for startup the diesel generator.

ATS: 230V output port when inverter is on.

RSD\_short signal/RSD\_voltage signal(B,B+,-): When the terminal "B" & "B" is short-circuited with additional wire connection, or there's 12Vdc input at the terminal "+ & -", then the 12Vdc of RSD+ & RSD- will disappear immediately, and the inverter will shutdown immediately.

RSD\_12V\_out(17,18): When battery is connected and the inverter is in "ON" status, it will provide 12Vdc.

DI+,DI-: According to "Article 14a of the German Energy Industry Act (EnWG)" (2024) The Energy Industry Act, The digital interface DI of the hybrid inverters can receive an external control signal to reduce the charging power from the grid to less than 4.2kW. When the signal disappears, the inverter can return to its previous operating state. Note: This newly developed interface may not have in older hardware versions of inverters.

ATS Switch: This DIP Switch (2 set ) is used to turn on/off the output voltage of ATS port. When both of them is in "ON" position, then the output voltage of ATS port will be active. When both of them is in "OFF" position, then the output voltage of ATS port will be not active.

Paralle Switch: Parallel communication resistor. If the number of inverters in the parallel system is less than or equal to 6, all inverter's DIP switch (1&2) need be ON position. If the number of inverters in parallel system exceeds 6, the main 6pcs inverter's DIP switch needs to be ON position. And the other inverter DIP switch (1&2) needs to be OFF position.

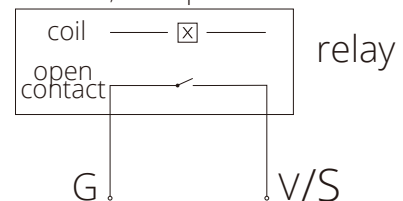

GV/GS

(diesel generator startup signal)

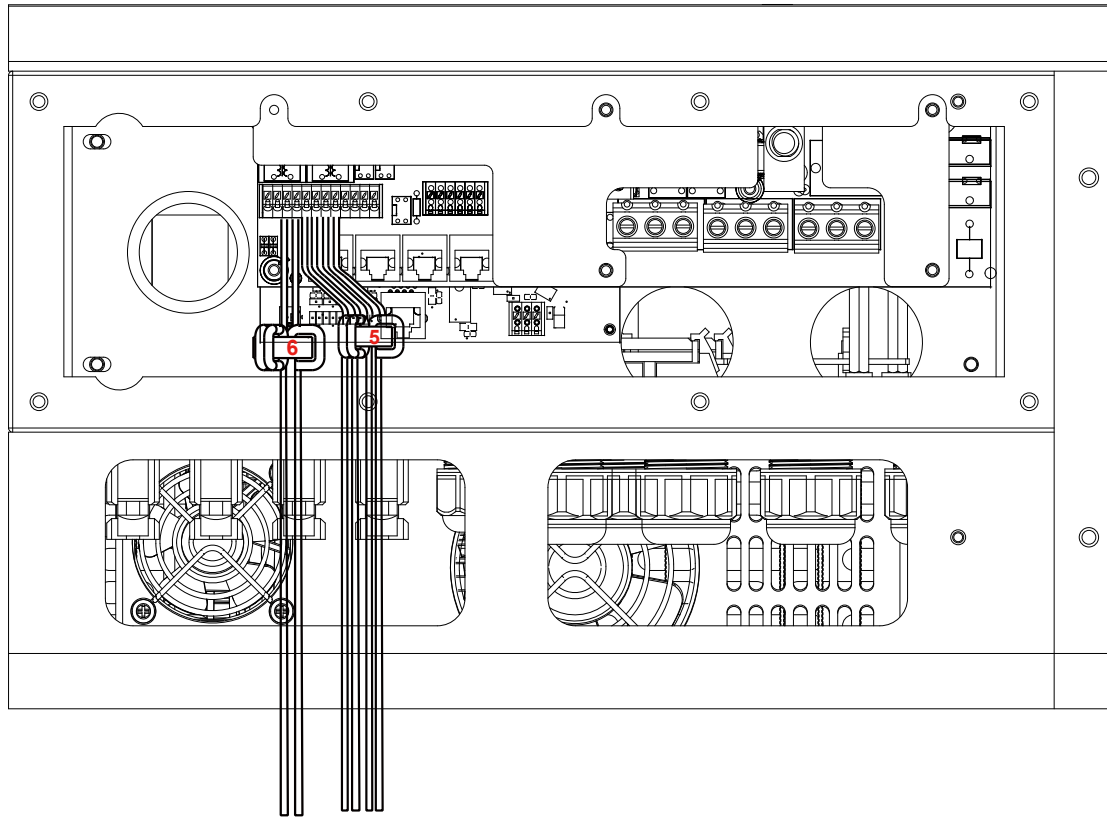

No.	Function Port	Installation Instructions
5	G-V (5,6) G-S (7,8)	Wrap the wires three laps around the magnetic ring, then thread the end of wires through the magnetic ring.
6	CT(3,4)	Wrap the wires three laps around the magnetic ring, then thread the end of wires through the magnetic ring.

# Battery Temperature Sensor Connection

Without a remote temperature sensor, lead-acid batteries may undercharge or overcharge depending on the ambient temperature of the installation environment. This may result in a fire hazard.

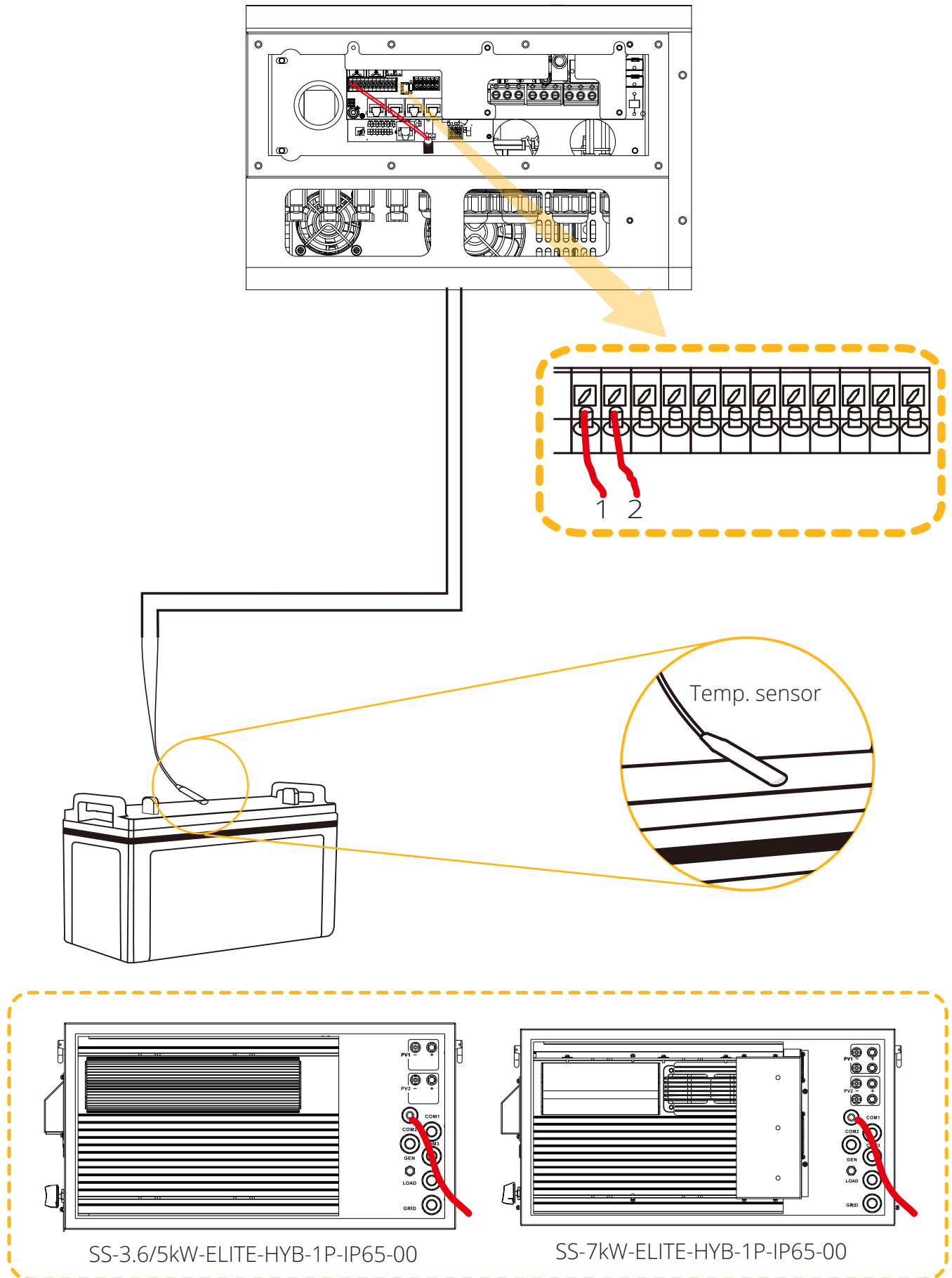

# Grid, Load, and Generator Connections

Before connecting the inverter, ensure the installation of dedicated AC breakers on the Grid, Load, and GEN/AUX connections. These breakers ensure safe isolation during maintenance, protect against overcurrent, and enhance system safety.

The inverter system includes three terminal blocks, labelled "Grid", "Load", and "GEN", which must be correctly identified and connected to their respective input and output terminals.

For the 3.6/5/6 kW model, a 40 A AC breaker is recommended for the grid connection. Breaker sizing for Load and GEN connections should be selected based on the connected load and generator specifications.

## GEN/AUX, GRID, AND LOAD CONNECTIONS

1. GEN/AUX – Generator Connection: The GEN/AUX terminal connects to a generator or auxiliary power source. It provides an input connection to the inverter, allowing it to receive power from the generator during periods when solar energy is insufficient, ensuring a continued power supply to the system.

Explanation: The inverter can work in parallel with a generator (e.g., diesel, wind, or hybrid systems) to provide power when the solar system or battery is insufficient. It ensures that the inverter can always keep essential loads powered, regardless of available solar power.

2. GRID – Grid Connection: The GRID terminal operates similarly to a conventional grid-tied inverter. It functions as both an input and an output connection:

- Input: The inverter receives grid power when solar generation is insufficient or when battery levels are low.
- Output: The inverter can supply excess energy back to the grid or provide power to non-essential loads when required.

Explanation: In grid-connected systems, the GRID terminal facilitates power flow both from and to the grid. When there is excess solar power, it can be fed back to the grid, while during cloudy days or at night, the inverter will draw power from the grid to meet energy demand.

3. LOAD – Essential Load Connection: The LOAD terminal is dedicated to connecting essential loads within your system. These typically include critical systems such as:

- Lighting
- Security systems
- Communication systems (e.g., internet or telecommunication devices)

This ensures that these essential loads receive power directly from the inverter, even during grid outages or when other non-essential loads are disconnected.

Explanation: By isolating non-essential loads and prioritising essential ones, the system ensures that critical appliances or systems remain operational, even in an off-grid scenario.



### WARNING

- During final installation, ensure that a breaker certified according to IEC 60947-1 and IEC 60947-2 is installed with the equipment.
- All wiring must be carried out by qualified personnel to ensure system safety and proper operation.
- Use appropriate cables for the AC input connection as specified below.
- To minimise the risk of injury and ensure safe operation, always use the recommended cables.

Recommended Size for AC wires:

Model	Wire Size	Cable (mm <sup>2</sup> )	Torque Value (max.)	Phase
SS-3.6/5kW-ELITE-HYB-1P-IP65-00	8AWG	6	1.2N.m	L+N
SS-7kW-ELITE-HYB-1P-IP65-00	6AWG	10	1.2N.m	L+N

## INSTALLATION PROCEDURE

Follow the steps below to complete the AC input and output connections. This procedure must be carried out by qualified personnel.

1. Isolate power sources: Before connecting the Grid, Load, and Generator terminals, ensure that the AC breaker or disconnecter is switched off to prevent electrical hazards.
2. Prepare the wires:
  - Strip 10 mm of insulation from each wire end.
  - Loosen the terminal screws and ensure the terminals are ready to receive the wires.
3. Pass through magnetic ring: Thread each AC wire through the magnetic ring as shown in the installation diagram. This step is required for EMC (electromagnetic compatibility) compliance.

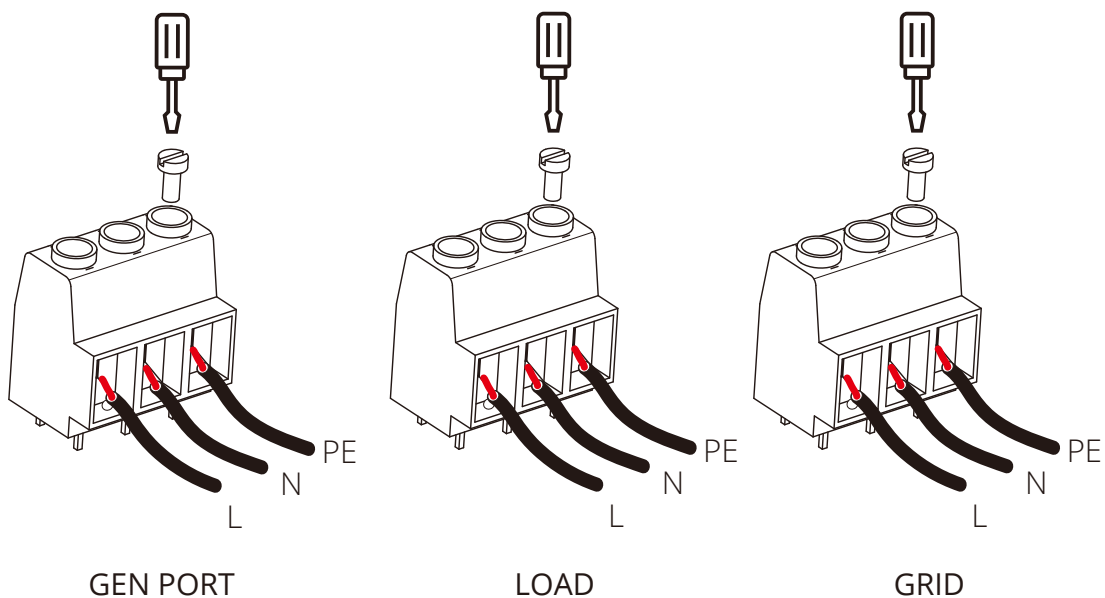
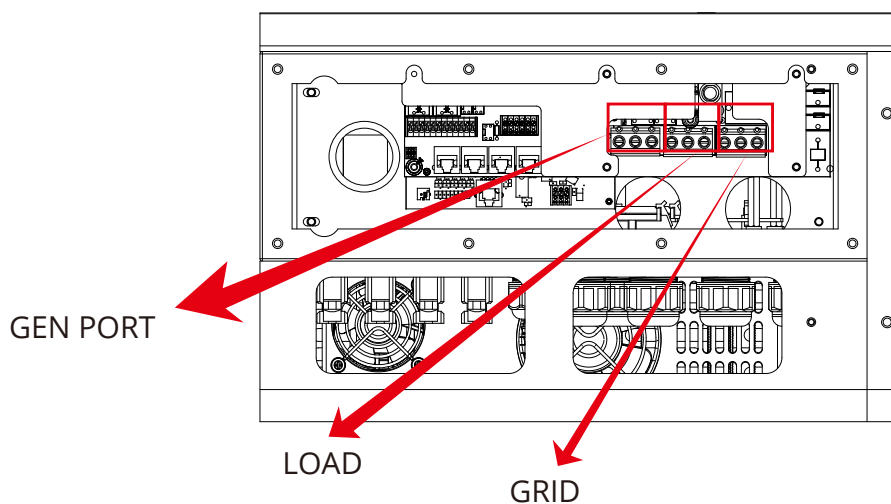
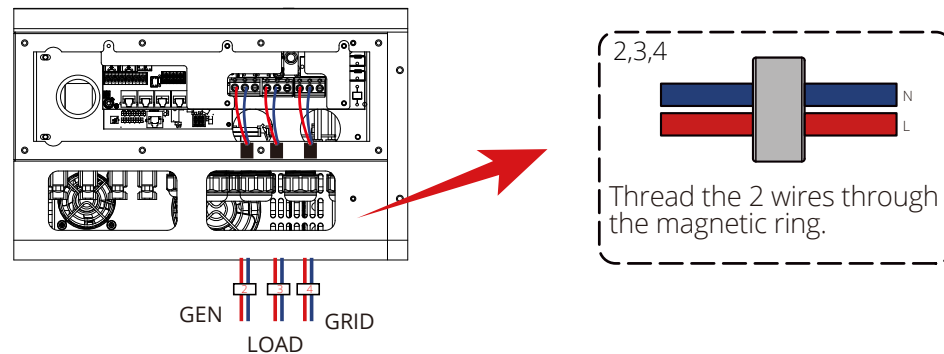

4. Connect to terminal block:
  - Insert the wires into the terminal block according to the indicated polarity (L – Live, N – Neutral, PE – Protective Earth).
  - Tighten the terminal screws securely to ensure firm and safe connections. Verify that all wires are correctly and securely fastened.
5. Connect the AC output:
  - Insert the AC output wires into the appropriate terminals, again observing the correct polarity.
  - Connect the Neutral (N) and Earth (PE) wires to their corresponding terminals.



### NOTICE

Ensure all AC terminals are securely connected. Loose terminals may cause overheating, arcing, or system faults.

### APPLIANCE RESTART WARNING

- Check with the appliance manufacturer to confirm whether a built-in time-delay function is included.
- If no such function is present, the inverter may enter overload protection mode and disconnect the output to protect the appliance.
- However, sudden reconnection without delay can still result in permanent damage to sensitive equipment like air conditioners.



### CAUTION

Compressor-based appliances, such as air conditioners, require a restart delay of 2–3 minutes to allow refrigerant pressure to stabilise.

If power is interrupted and restored too quickly, this may damage the appliance's internal components.

### Recommendations:

- Always follow proper torque values for secure terminal tightening.
- Ensure correct wire routing through the magnetic ring for compliance.
- Use only recommended cable sizes as per model specification.
- Do not skip the restart delay check for compressor-based loads.

## Recommended AC Surge Protector

An AC surge protector is highly recommended for every inverter installation. It protects the inverter, battery system, and connected loads from transient overvoltages caused by lightning strikes, grid switching events, or other electrical disturbances.

The AC surge protector absorbs high-voltage surges and diverts excess energy safely to earth, preventing damage to the system's internal components.

### Key Benefits:

- Prevents damage to sensitive inverter electronics.
- Increases the lifespan of the inverter and other connected devices.
- Ensures system reliability, especially in areas with unstable grid voltage or frequent lightning activity.
- Required for compliance with local and international electrical installation standards.

### INSTALLATION GUIDELINES

#### 1. Install between the grid and inverter:

- The surge protection device should be installed between the AC grid supply and the inverter's AC input terminal.
- It must be connected as close as possible to the point of entry of the AC supply to ensure maximum protection.

#### 2. Connect to earth:

- Ensure the surge protector is properly earthed. A poor or missing earth connection will render the device ineffective and unsafe.
- The earth connection must be stable and reliable to protect the entire system effectively.

#### 3. Enclosure requirements:

- The AC surge protection system should be installed in a weatherproof IP-rated enclosure if mounted outdoors.
- The diagram shows an example of a surge protection box with an integrated rotary isolator, MCBs (Miniature Circuit Breaker), and SPD (Surge Protection Device).



### NOTICE

Surge protection devices cannot replace the need for proper grounding. Always verify that the inverter, SPD, and distribution board are connected to a properly tested earth point to ensure complete system safety.

## PV Connection

Before connecting the PV modules to the inverter, a separate DC circuit breaker must be installed between the inverter and the solar array. This is critical for ensuring system safety and efficient operation. Always use the correct cable size as specified below:

Model	Wire Size	Cable (mm <sup>2</sup> )
SS-3.6/5/7kW-ELITE-HYB-1P-IP65-00	12AWG	2.5



### WARNING

Do not connect any PV modules that may have potential leakage to the inverter. Leakage could cause malfunction or even damage to the inverter. When connecting the PV modules, ensure the positive (+) and negative (-) terminals are correctly aligned and not grounded.

It is recommended to use a PV junction box with surge protection to prevent damage from lightning strikes or other electrical disturbances affecting the solar modules.

## PV Module Selection

When selecting PV modules, please consider the following parameters to ensure proper operation and compliance with system requirements:

1. Open circuit voltage (Voc): The Voc must not exceed the maximum input voltage rating of the inverter to prevent overvoltage conditions and ensure the system operates safely.
2. Voc should be higher than the inverter's minimum start-up voltage: The Voc should exceed the inverter's minimum start-up voltage to ensure that the inverter can begin operating correctly under all conditions.
3. Class II certification: The PV modules connected to this inverter must be Class II rated and certified according to IEC 61730. This certification ensures the modules meet international safety standards and are suitable for use with the inverter.
4. Short-circuit current (Isc): The short-circuit current (Isc) of the PV array must not exceed the maximum input current rating of the inverter. Exceeding this value could cause damage to the inverter and pose a safety risk.
5. Ensure proper system compatibility:
  - The modules must be selected in accordance with the inverter's maximum voltage and current ratings.
  - Always verify that the system's design allows for safe operation under various conditions, including shading and environmental factors that may affect performance.

Inverter Model	SS-3.6/5kW-ELITE-HYB-1P-IP65-00	SS-7kW-ELITE-HYB-1P-IP65-00
PV Input Voltage	370V (125V~500V)	
PV Array MPPT Voltage Range	150V~425V	
No. of MPP Trackers	2	
No. of Strings per MPP Tracker	1+1	2+2

# CT Coil Connection

The CT (Current Transformer) coil is a crucial component of the Sunsynk Parity inverter, responsible for enabling the Zero Export feature. This feature prevents the inverter from feeding excess power back to the grid by monitoring the flow of power.

## INSTALLATION STEPS

1. Fit the CT coil:
  - Position the CT coil (sensor) around the live cable of the main fuse that supplies power to the building.
  - Ensure that the coil is installed correctly to measure the current flow accurately.
2. Run the cable to the inverter:
  - Extend the cable from the CT coil to the inverter. The cable length can be extended beyond 10 meters if you're using an external meter.
  - Always refer to the meter's manual to confirm the maximum allowed cable length for your installation.
3. Connect to the inverter: Connect the other end of the CT coil cable to the inverter's CT coil terminals, which are clearly marked as "CT coil".

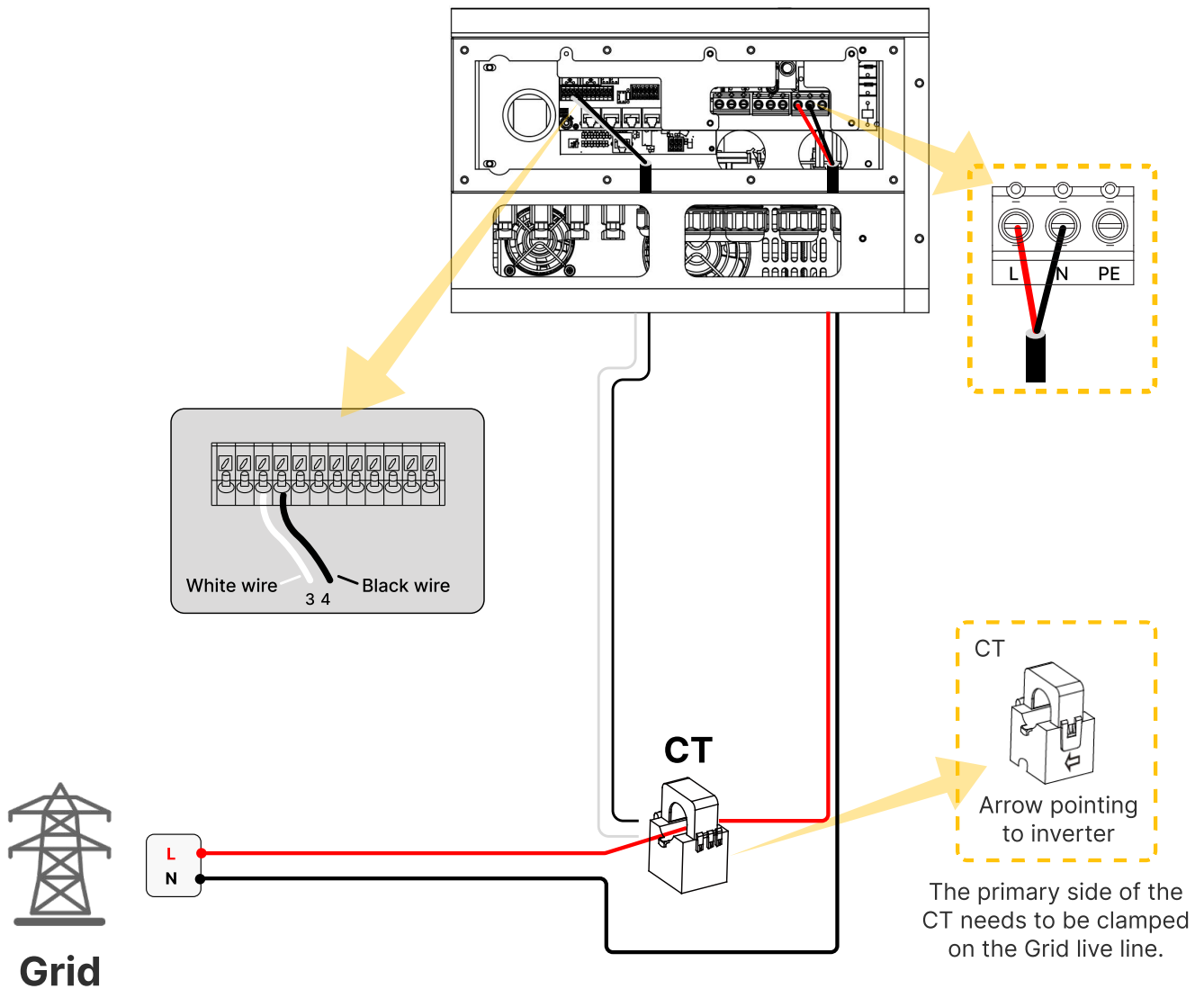

### WARNING

If the load power reading on the LCD display is incorrect, reverse the CT arrow to correct the reading.

# Meter Connection

## CHINT Meter

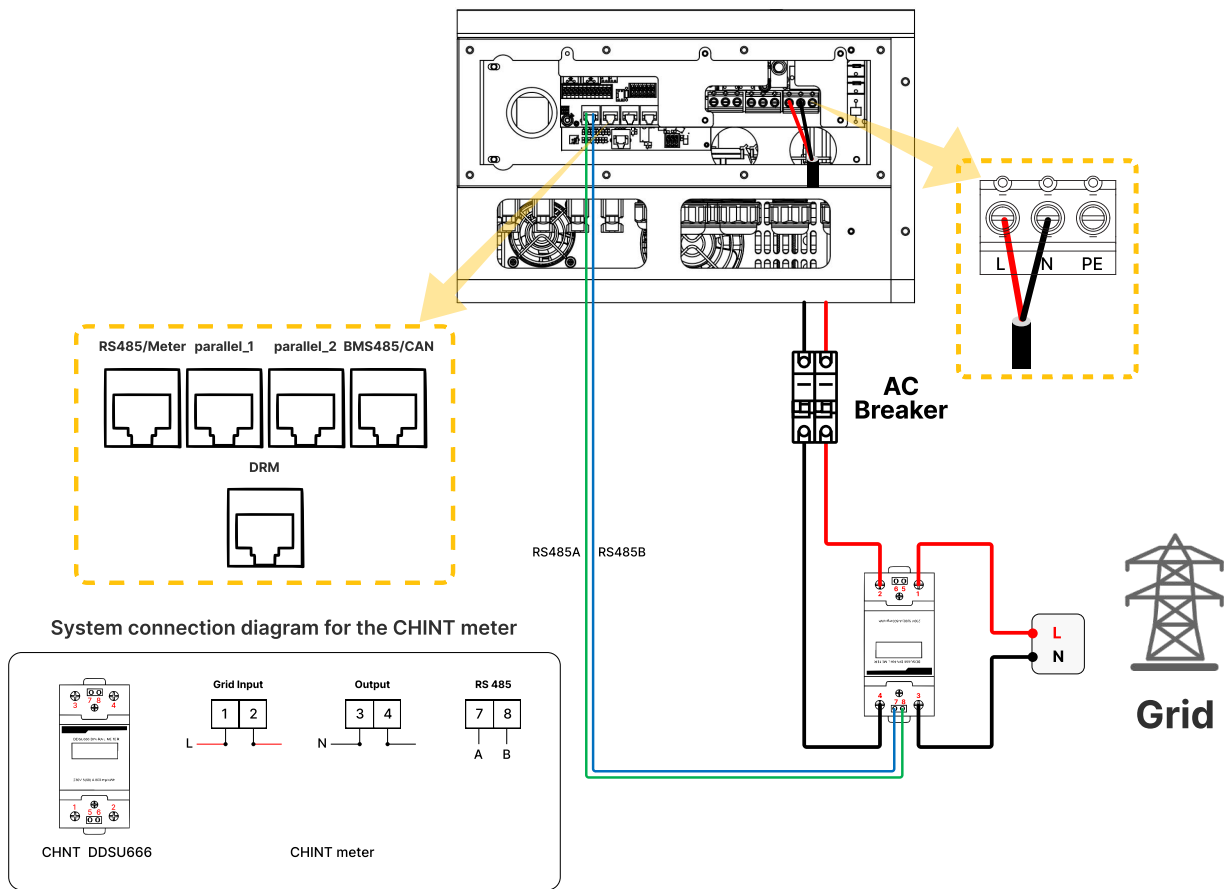

## Eastron Meter

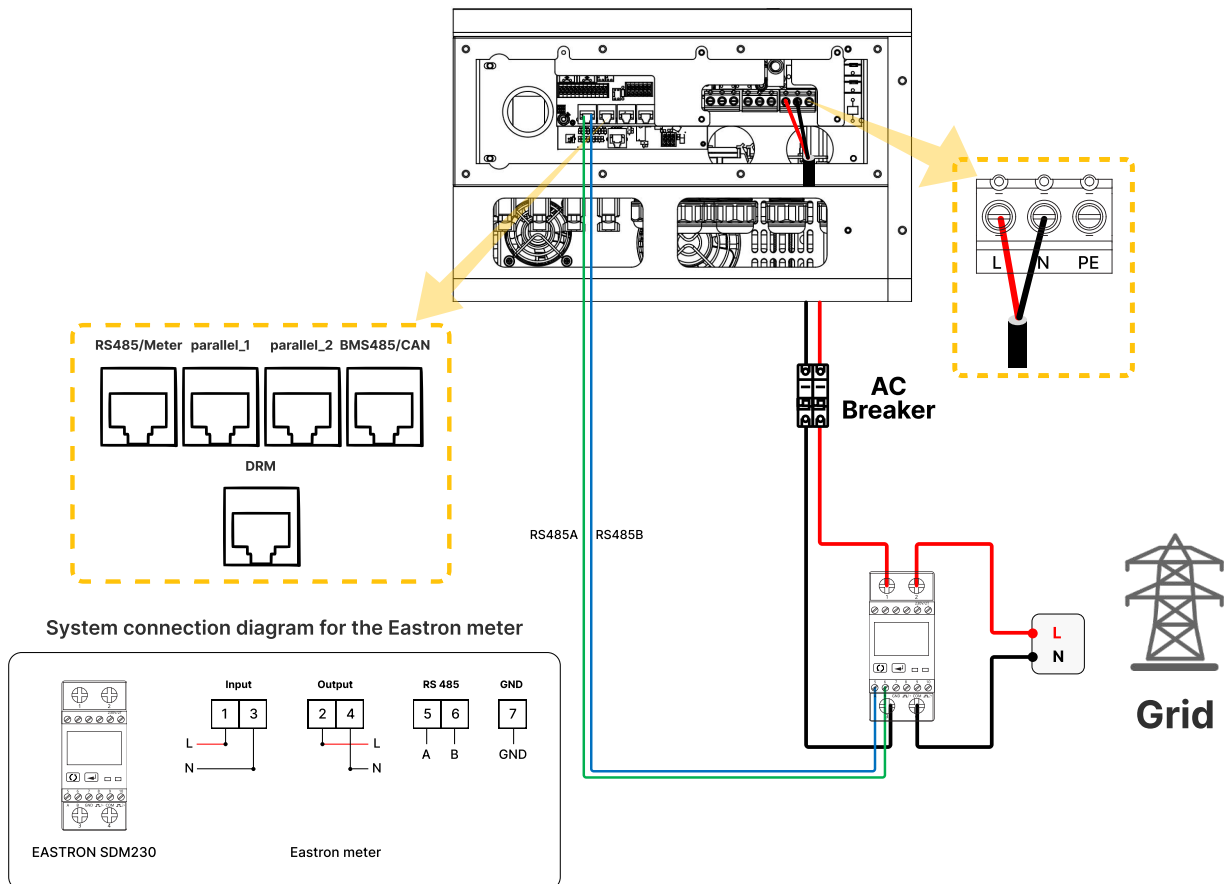

## Meter Communication

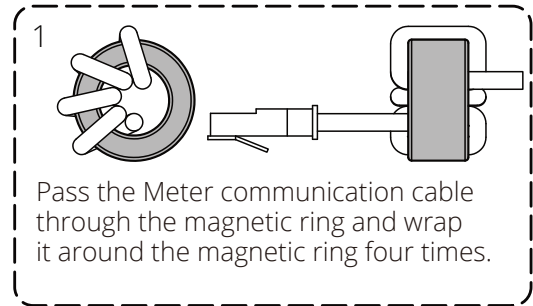
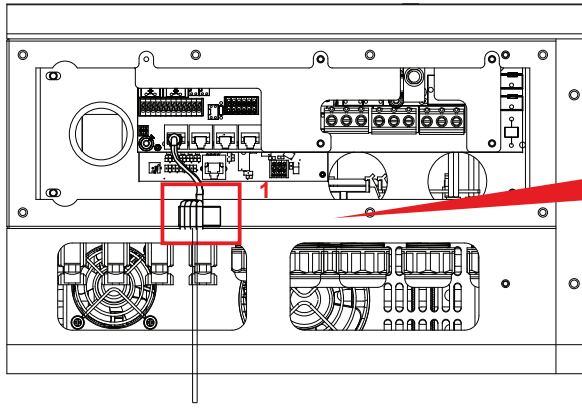

## Earth Connection (MANDATORY)

To ensure electrical safety and compliance, an Earth Cable must be connected to the earth plate on the grid side of the inverter. This connection protects users and equipment in the event of a fault or insulation failure by providing a safe path for fault current. Please see below the purposes of correct earthing:

- Prevents electric shock during fault conditions.
- Ensures proper functioning of RCDs (Residual Current Devices).
- Protects the inverter and loads from surge damage and leakage current.
- Reduces the risk of fire due to electrical faults.

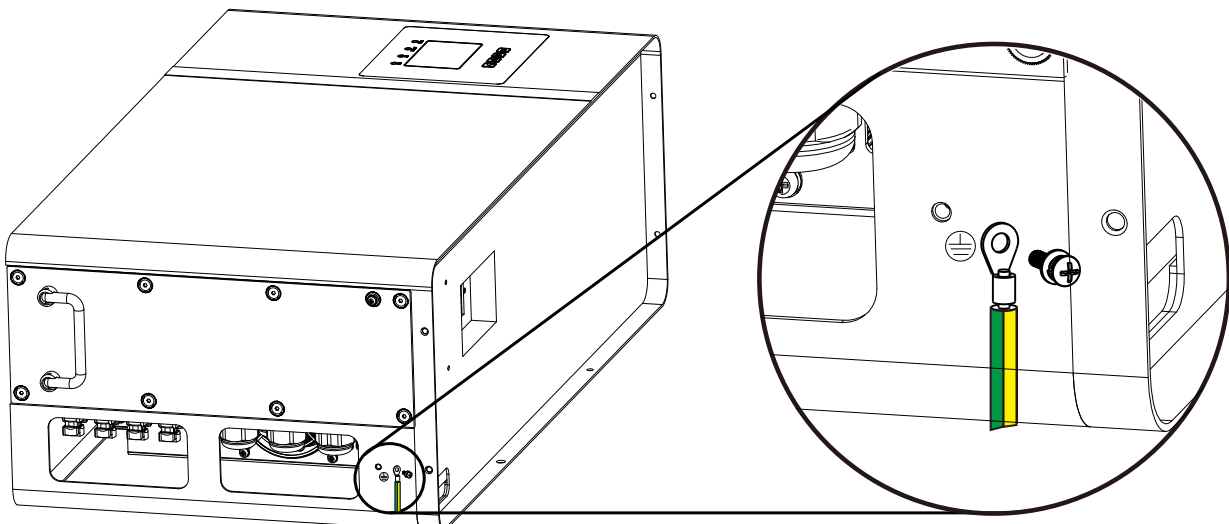
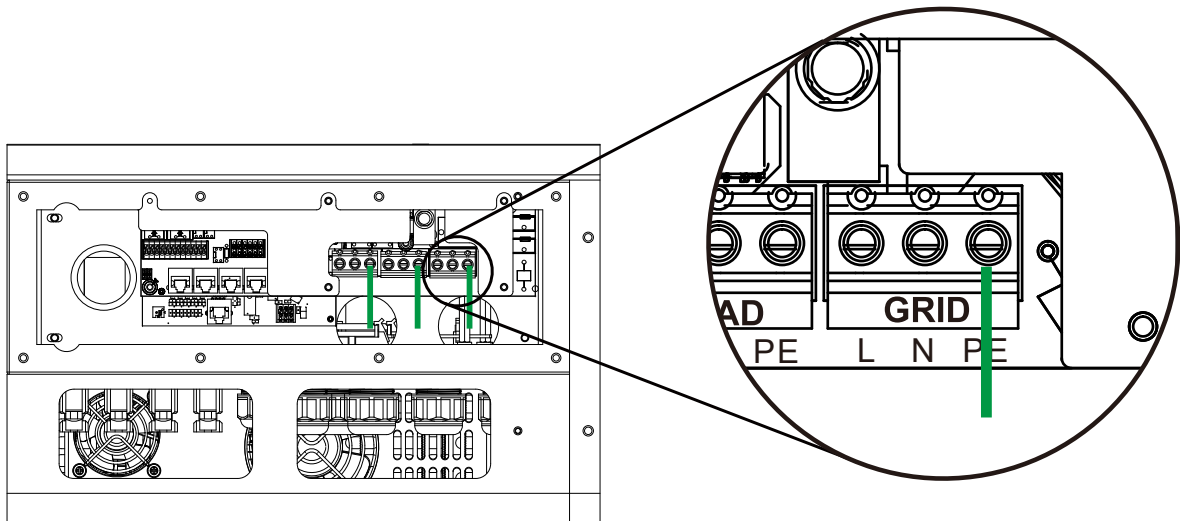

## Earth connection(Copper wires)

Model	Wire Size	Cable (mm <sup>2</sup> )	Torque Value (max.)	Phase
SS-3.6/5kW-ELITE-HYB-1P-IP65-00	8AWG	6	1.2N.m	L+N
SS-7kW-ELITE-HYB-1P-IP65-00	6AWG	10	1.2N.m	L+N



### WARNING

Ensure the earth cable is securely tightened using the correct torque value to maintain reliable grounding.

### NEUTRAL-EARTH BONDING AND SYSTEM TYPES

- All neutrals can be linked together to maintain the neutral-earth bond.
- In off-grid or backup mode, a Neutral-Earth bond is required and is handled automatically by the inverter's internal relay.
- In grid-tied mode, this bond must be disconnected, or it can cause RCD faults. The inverter's auto-bond relay ensures this transition is done safely.



### CAUTION

If a permanent earth bond is used between neutral and earth in a hybrid system, it may cause unwanted RCD tripping unless properly managed.



### NOTICE - For South Africa

- It is recommended to install a permanent PE/N bond on the Load Output terminal.
- The AC supply to the grid port should be taken upstream of the main RCD to avoid nuisance tripping.
- This bond must be clearly marked (e.g. "Permanent PE/N Bond") and installed in accordance with local regulations.
- Always consult your local authority or electrical inspector when installing in regions with specific bonding rules.

### LEAKAGE CURRENT DETECTION AND RDC USE

The inverter is equipped with built-in leakage current detection. You may connect a Type A RCD to the inverter's AC output for additional protection.



### WARNING

If using an external RCD, its rated residual operating current must be  $\geq 300$  mA. Lower-rated RCDs may trip unnecessarily due to inverter switching behaviour.

# Wiring System for Inverter

When the inverter is working in backup(off-grid) mode, please refer to section 5.10 to connect the neutral and PE terminals on the Load port via the external relay. In some versions of hardware, relay may already be built-in to achieve this function. Please refer to the actual received product.

This diagram is an example for grid systems without special requirements on electrical wiring connection.  
 Note: The back-up PE line and earthing bar must be grounded properly and effectively.  
 Otherwise the back-up function may be abnormal when the grid fails.

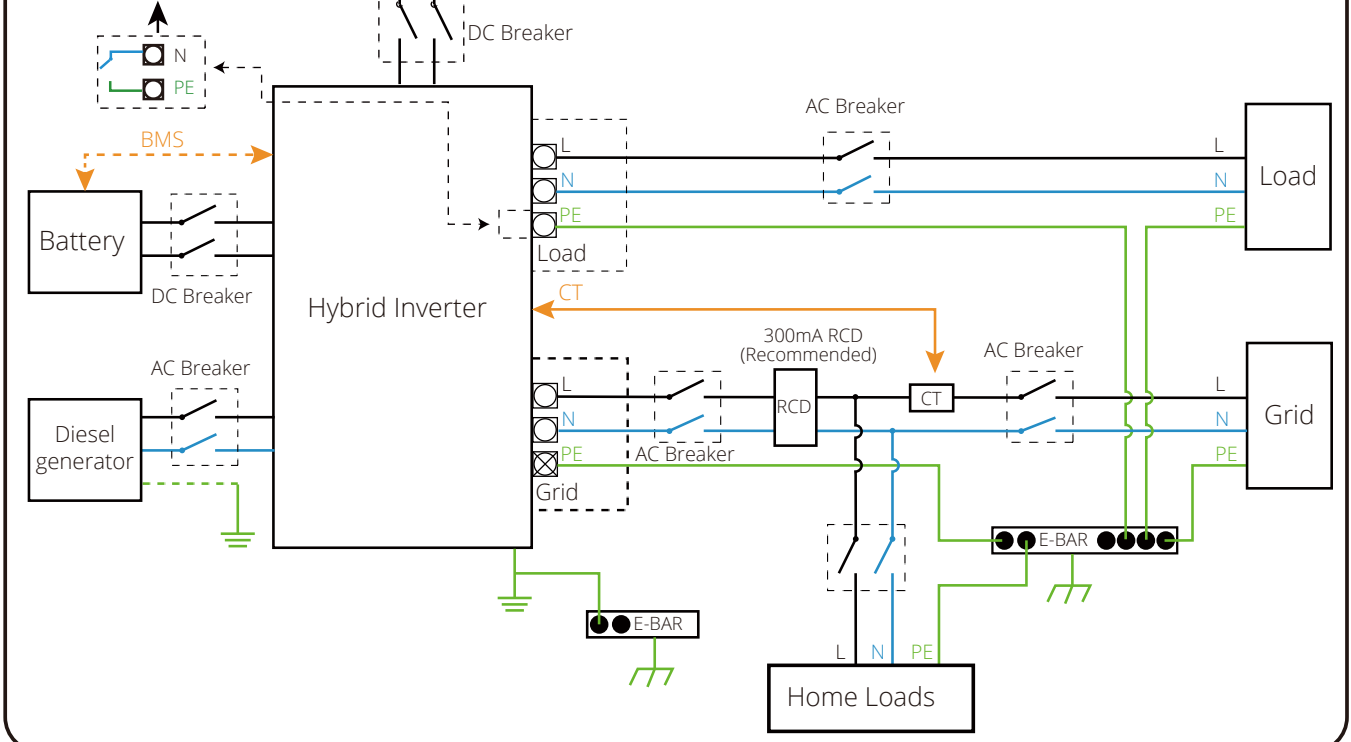

This diagram is an example for application that Neutral connects together with PE in distribution box.  
 Such as: Australia, New Zealand, etc. (Please follow local wiring regulations!)

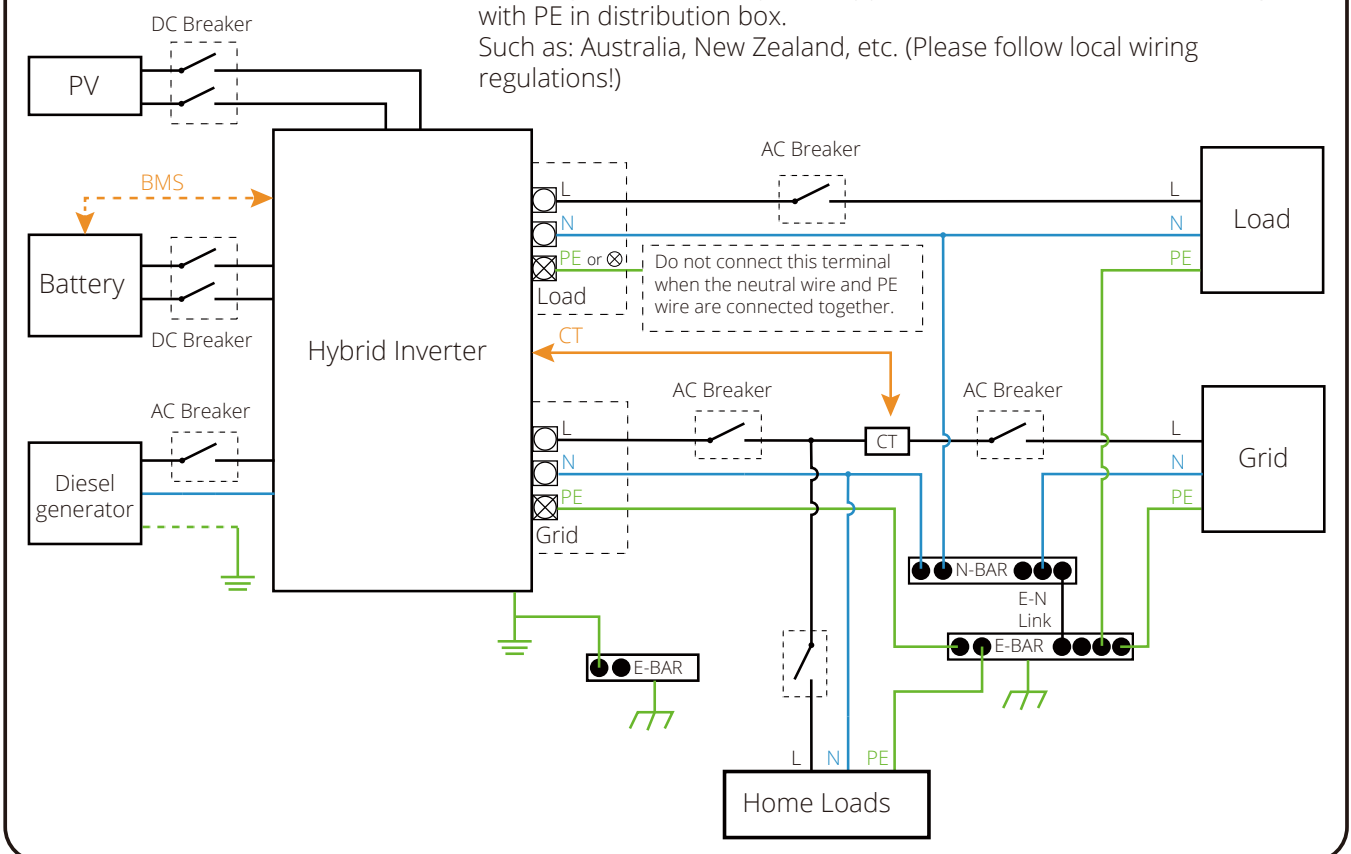

# Typical Application of Diesel Generator

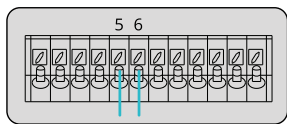

GV/GS: Dry contact signal for startup the diesel generator.

When the "GEN signal" is active, the open contact (GV/GS) will switch on (no voltage output). If the "Signal ISLAND MODE" is ticked, the GS port will be the dry contact signal for startup the diesel generator. If "Signal ISLAND MODE" is not ticked, the GV port will be the dry contact signal for startup the diesel generator.

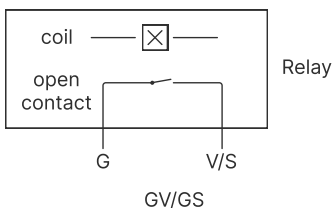

(Diesel Generator Startup Signal)

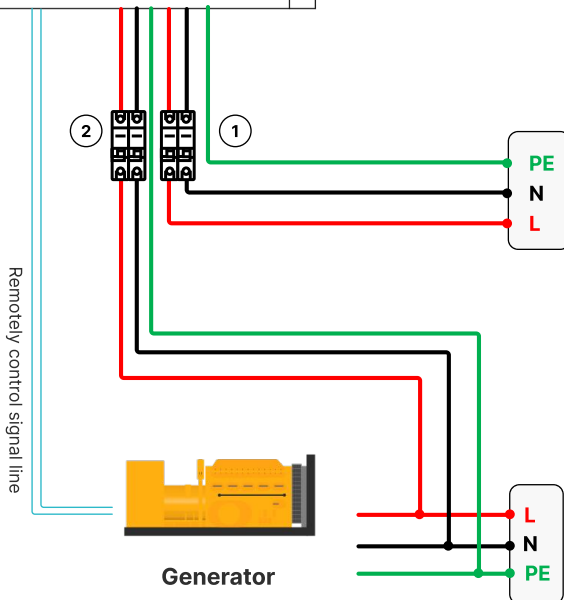
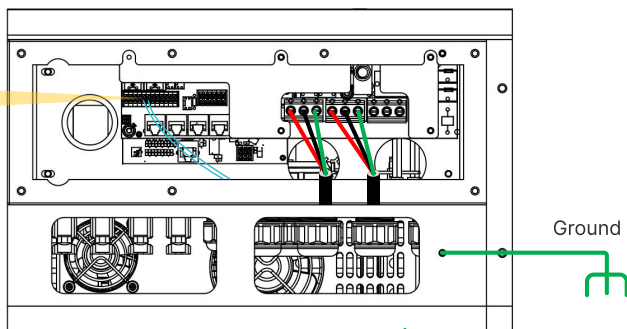

Backup Load

## ① AC Breaker for Backup Load port

SS-3.6kW-ELITE-HYB-1P-IP65-00: 40A AC breaker

SS-5kW-ELITE-HYB-1P-IP65-00: 40A AC breaker

SS-7kW-ELITE-HYB-1P-IP65-00: 50A AC breaker

## ② AC Breaker for Generator port

SS-3.6kW-ELITE-HYB-1P-IP65-00: 40A AC breaker

SS-5kW-ELITE-HYB-1P-IP65-00: 40A AC breaker

SS-7kW-ELITE-HYB-1P-IP65-00: 50A AC breaker

# Single-Phase Parallel Connection

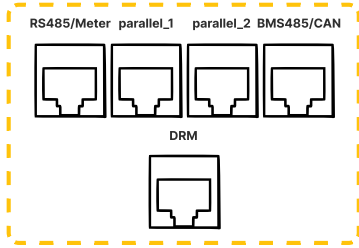
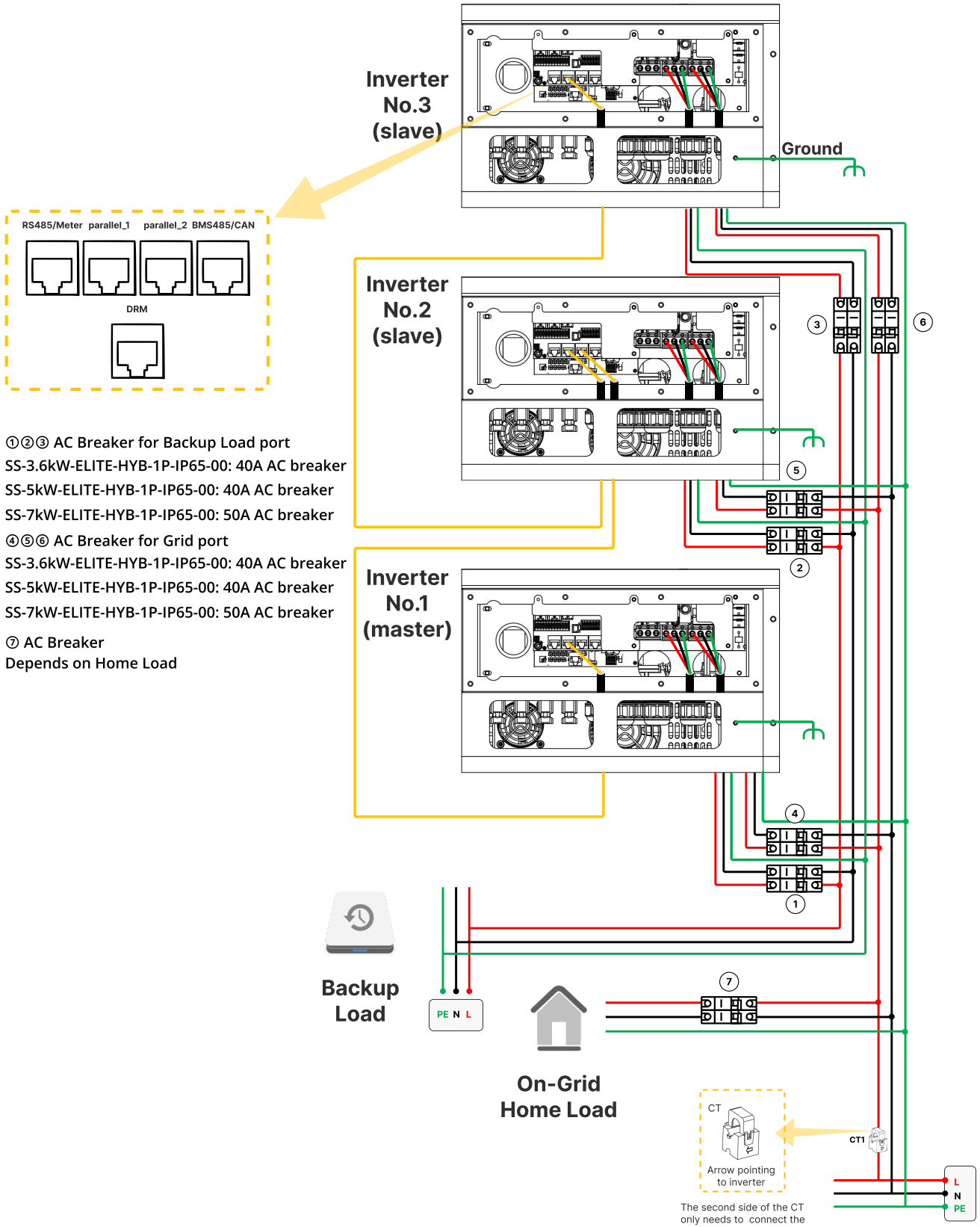

**Master Inverter**

ADVANCE

Multi-Inverter Others P-Shave Wind Turbine

Parallel  Master Modbus SN 01  Phase A  
 Slave  Phase B  
 Ex\_Meter for CT  Phase C

Meter Select  
 No Meter 0/4

Cancel OK

**Slave Inverter**

ADVANCE

Multi-Inverter Others P-Shave Wind Turbine

Parallel  Master Modbus SN 02  Phase A  
 Slave  Phase B  
 Ex\_Meter for CT  Phase C

Meter Select  
 No Meter 0/4

Cancel OK

**Slave Inverter**

ADVANCE

Multi-Inverter Others P-Shave Wind Turbine

Parallel  Master Modbus SN 03  Phase A  
 Slave  Phase B  
 Ex\_Meter for CT  Phase C

Meter Select  
 No Meter 0/4

Cancel OK

# Three-Phase Parallel Inverter

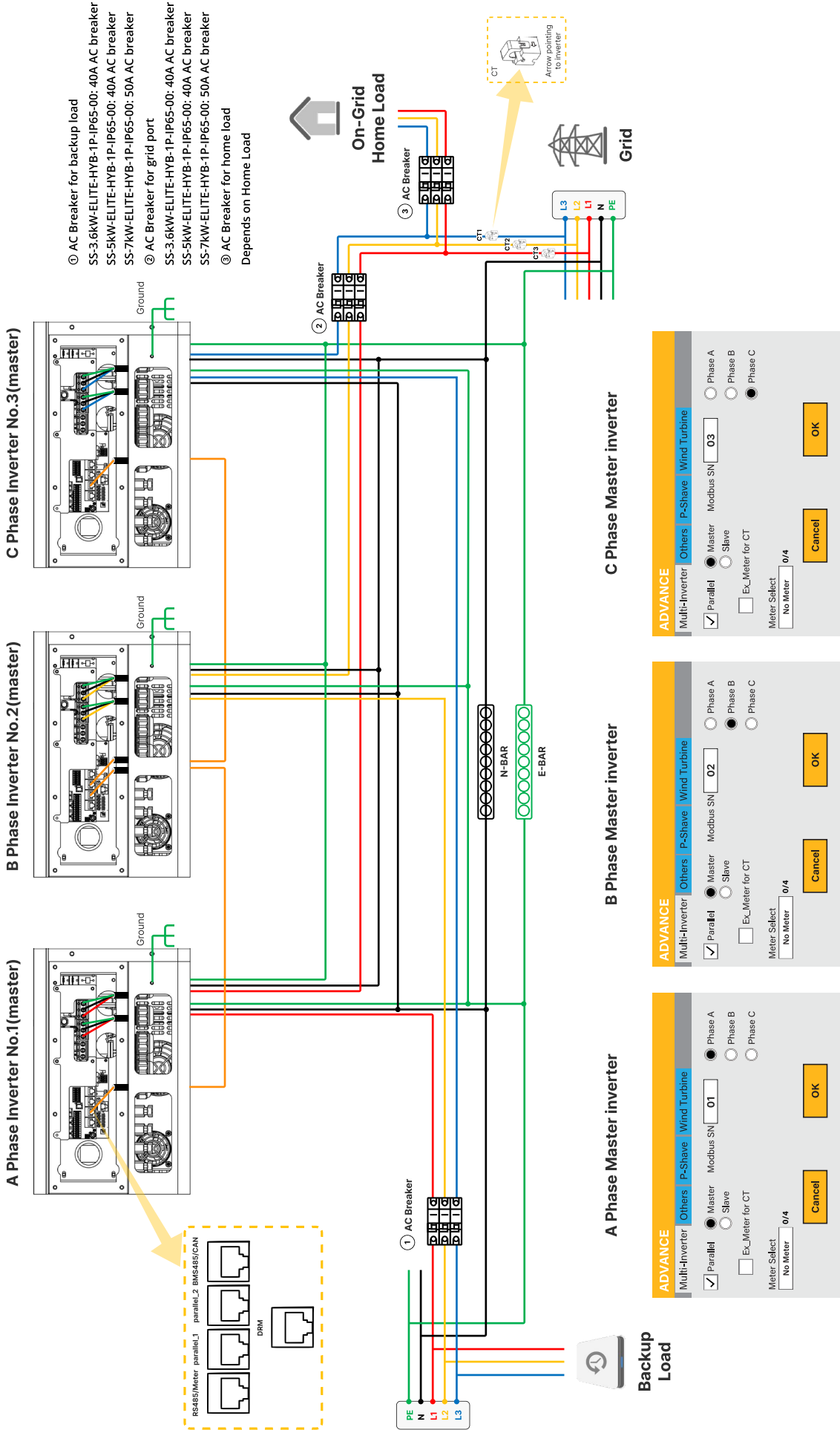

# OPERATION

## Switching ON/OFF

Before switching on the inverter, ensure that all wiring is complete and the battery connection is secure.

- To turn on the inverter, press the ON/OFF button located on the left side of the inverter case.
- When the inverter is powered by PV or grid supply but has no battery connected, the LCD screen will still illuminate, even if the ON/OFF button is off. The display will indicate that the system is in standby mode.
- In this state, press the ON/OFF button, then select 'No Battery' from the startup options. The system will begin operating using available PV or grid power only.



### NOTICE

The inverter can operate without a battery if either PV or grid input is present. However, battery features such as backup and storage will not be available in this mode.

## Display

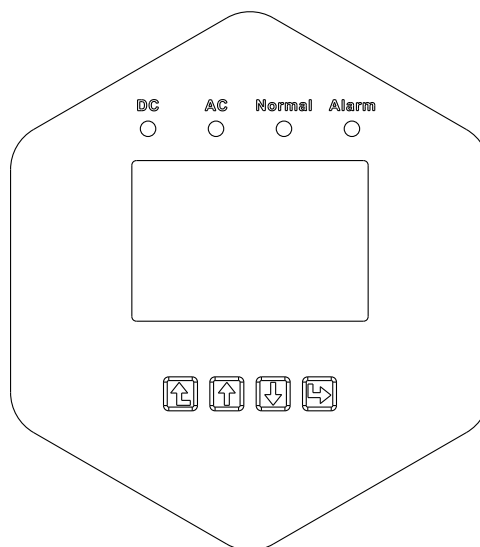

## LED Indicators

LED Indicator		Meaning
DC	Green LED solid light	PV connection normal
AC	Green LED solid light	Grid connection normal
Normal	Green LED solid light	Inverter functioning normally
Alarm	Red LED solid light	Fault

## Function Buttons

Function Key	Description
Esc	To exit the previous mode
Up	Increase the value of a setting
Down	Decrease the value of a setting
Enter	Confirm setting change (If not pressed each time the setting will not be saved)

# LCD Operation Flow Chart

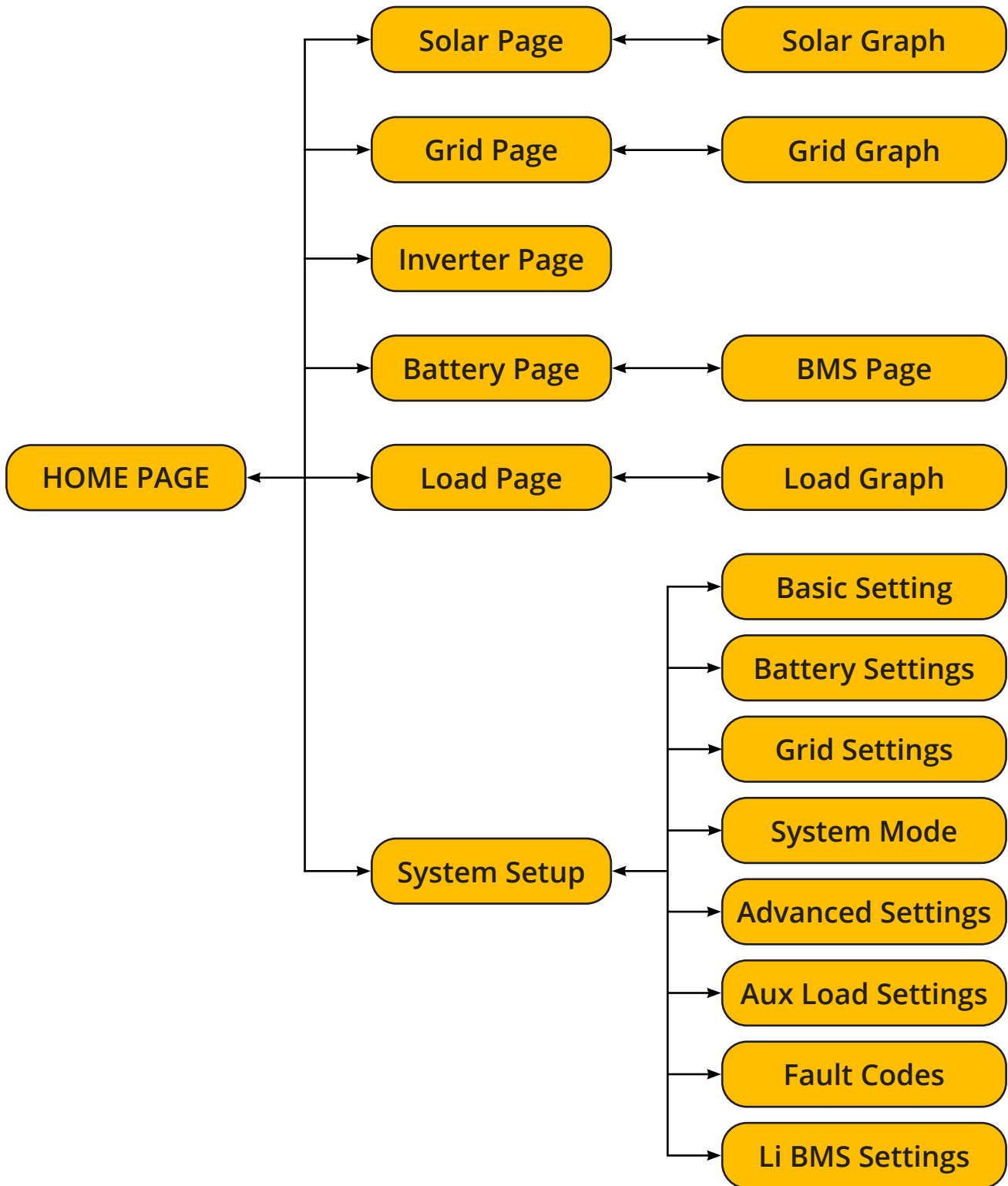

# Home Page

Press the Esc button any page to access the home page:

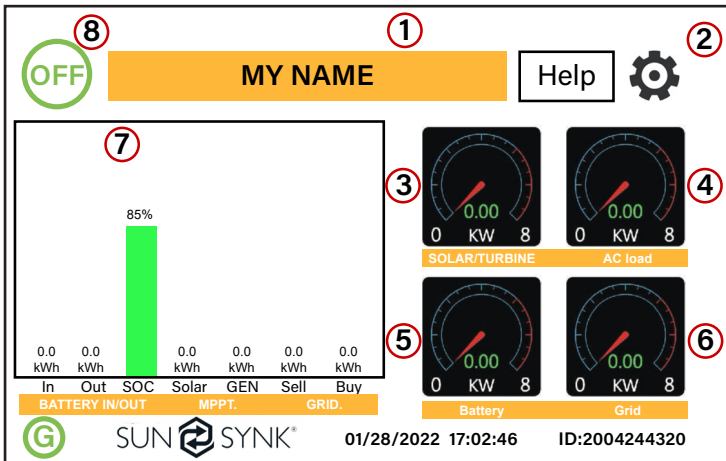

1. Customer name.
2. Access the settings menu page.
3. Access solar page.
4. Access load page.
5. Access battery page.
6. Access grid page.
7. Access system flow page.
8. Access fault code displays.

The icon (8) indicates that the system is operating normally. If the icon displays as "comm/F01-F64", it means there are communication errors or other issues with the inverter. The error message will appear under this icon (F01-F64 errors). Detailed error information can be accessed in the System Alarms menu.

## What this page displays:

- Total daily power into the battery (kWh).
- Total daily power out of the battery (kWh).
- SOC (State of charge of the battery) (%).
- Total daily solar power produced in (kWh).
- Total hourly usage of the generator (Time).
- Total daily power sold to the grid (kWh).
- Total daily power bought from the grid (kWh).
- Real-time solar power in (kW).
- Real-time load power in (kW).
- Real-time battery charge power in (kW).
- Real-time grid power in (kW).
- Serial number.
- Time date.
- Access the status page.
- Access the fault code displays.

# Status Page

To access the Status page, click on the BATTERY or AC LOAD dial on the Home page.

0 Watts 0% (SOC) 0.00 Volts 0.00 Amps 0.0 C	0 Watts 0 Hz 0 Volts 0.0 Amps CT: 0 Watts LD: 0 Watts	M1: 0 Watts 0 Volts 0.0 Amps M2: 0 Watts 0 Volts 0.0 Amps
<b>Battery</b>	<b>Grid Power</b>	
0 Watts 50.0 Hz 0 Volts 0.00 Amps	0 Watts 0 Volts	<b>Solar Power</b>
<b>Inverter Power</b>	<b>Load Power</b>	0 Watts 0 V/0.0 Hz
		<b>GEN</b>

## What this page displays:

- Solar Column:
  - Total solar power produced – Displays the overall solar power generated.
  - MPPT 1 power/voltage/current – Shows the power, voltage, and current for MPPT 1.
  - MPPT 2 power/voltage/current – Shows the power, voltage, and current for MPPT 2.
- Grid Column:
  - Grid power – Displays the total power imported from or exported to the grid.
  - Grid frequency – Shows the current frequency of the grid.
  - Grid voltage – Displays the grid's voltage.
  - Grid current – Displays the current being supplied or received from the grid.



### NOTICE

When exporting power to the grid, the grid power will be shown as a negative value. When consuming power from the grid, it will show as a positive value. If the grid and load power signs are different (when the PV is disconnected and the inverter is only receiving energy from the grid with the CT connected to Limit-2), please reverse the polarity of the CT coil.

**Important:** Refer to the section 'Connecting the CT Coil' for more details.

- Inverter Column:
  - Inverter power – Displays the total power generated or consumed by the inverter.
  - Inverter frequency – Shows the inverter's operating frequency.
  - Inverter voltage – Displays the voltage output from the inverter.
  - Inverter current – Displays the current being drawn or supplied by the inverter.
- Load Column:
  - Load power – Shows the total power consumed by the connected load.
  - Load voltage – Displays the voltage supplied to the load.
  - Power on L1 and L2 – Displays the power consumption for each phase (L1 and L2).
- Battery Column:
  - Battery power charge/discharge – Displays the current charge or discharge rate of the battery.
  - Battery SOC – Shows the current state of charge (SOC) of the battery.
  - Battery voltage – Displays the current voltage of the battery.
  - Battery current – Shows the current flowing to or from the battery (negative means charging, positive means discharging).
  - Battery temperature – Displays the temperature of the battery (will show as zero if the battery temperature sensor is not connected).
- Transformer and Heatsink Temperature:
  - DC transformer temperature – Displays the temperature of the DC transformer.
  - AC heatsink temperature – Displays the temperature of the AC heatsink.



### NOTICE

If the temperature reaches 90°C, it will be displayed in red. The inverter's performance will degrade at this temperature. If it reaches 110°C, the inverter will automatically shut down to cool and protect itself.

# System Flow Page

Access this page by clicking on the bar chart on the Home Page.

To better understand the functioning of your system, take a look at the flow diagram below:

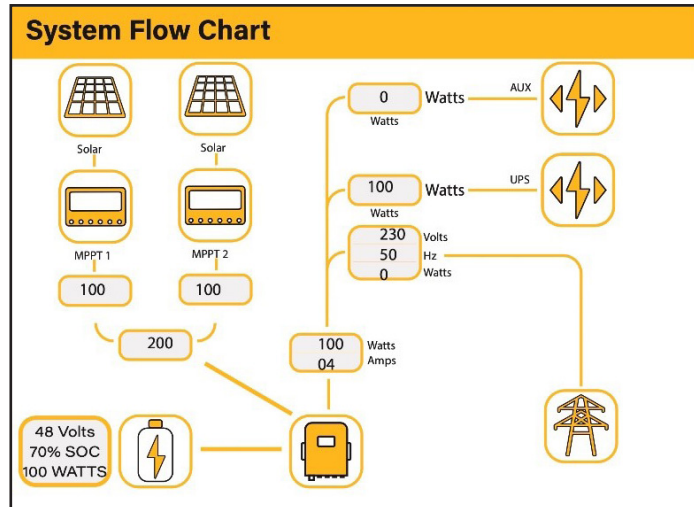

1. PV modules charge the batteries: The solar panels collect energy and charge the batteries.
2. Battery power is fed into the inverter: Once the batteries reach a pre-programmed charge level, the battery power is fed into the inverter.
3. Power supply to load, grid, or auxiliary load: The inverter can supply power to the grid (export or no export), to the load, or to auxiliary devices or smart loads.
4. CT coil controls the export power: The CT coil monitors the power export to the grid and controls it to ensure proper functioning.

## What This Page Displays:

- The system flow: Overview of how energy flows within the system, from solar generation to power distribution.
- MPPT power: The power being generated by each MPPT (Maximum Power Point Tracking).
- Battery status: Displays the current state of charge (SOC) of the batteries and their condition.
- Power distribution: Information on whether power is being supplied to the load, the grid, or auxiliary loads.

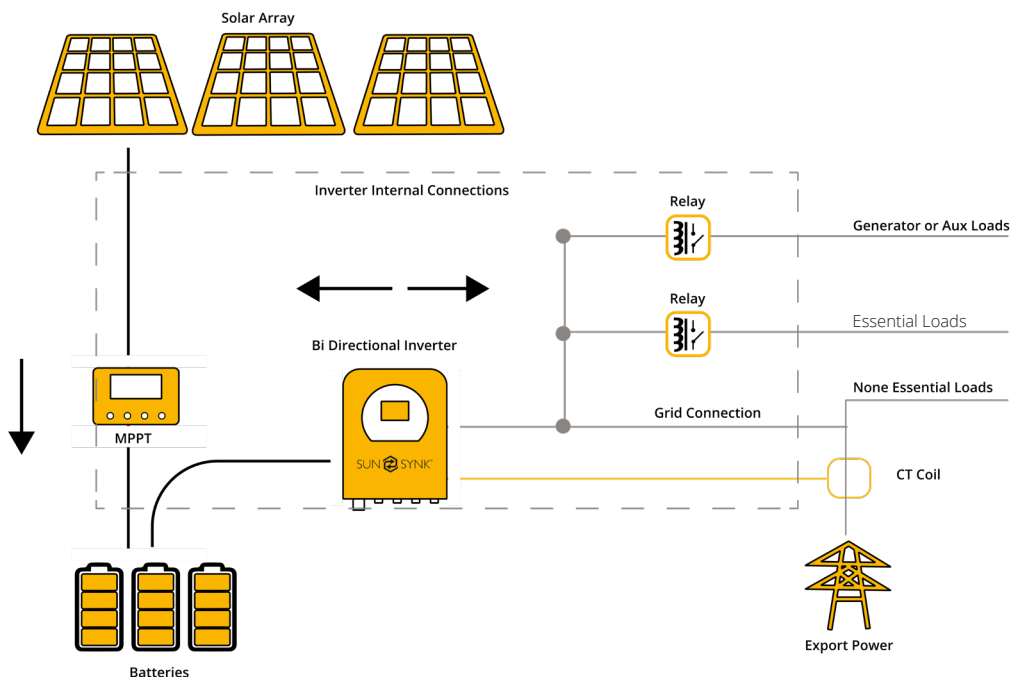

# Setup Page

To access Settings, click on the gear icon on the right top of the navigation menu.

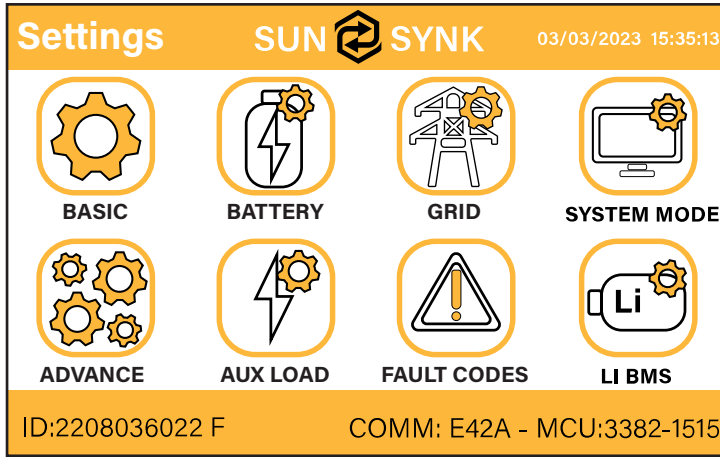

### What this page displays:

- Serial number.
- Software version.
- Time, Date, and MCU.

### What you can do from this page:

- Access the Basic Setup Page: Click the "BASIC" icon to configure basic settings.
- Access the Battery Setup Page: Click the "BATTERY" icon to configure battery settings.
- Access the Grid Setup Page: Click the "GRID" icon to configure grid-related settings.

- Access the Real-Time Programmable Timer/System Mode: Click the "SYSTEM MODE" icon to set the operational mode of the inverter.
- Access the Advanced Settings: Click the "ADVANCE" icon for settings related to paralleling, wind turbine configurations, and more.
- Access the Auxiliary Load/Smart Load Settings: Click the "AUX LOAD" icon to set up auxiliary or smart load functions.
- Access the Fault Code Register: Click the "FAULT CODES" icon to view any fault codes and system alerts.
- Set up Li BMS: Click the "LI BMS" icon to configure the Battery Management System (BMS) settings.

## Basic Setup

### Set Time (Clock)

To set time, click on the BASIC icon and then on 'Time'

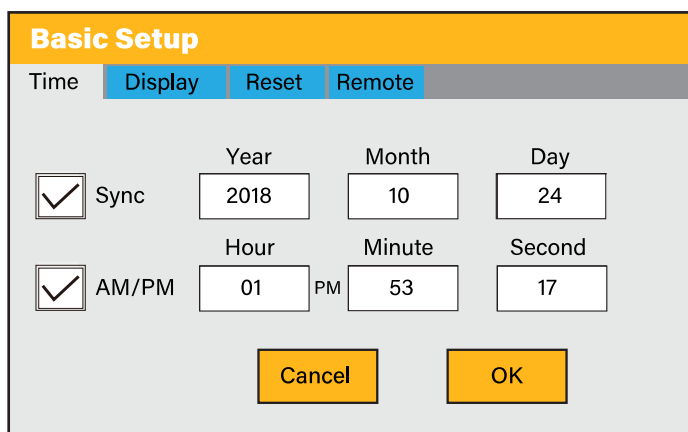

### What this page displays:

- Time: The current time of the inverter.
- Date: The current date.
- AM/PM: The time period format (AM or PM).

### What you can do from this page:

- Adjust or set the time.
- Adjust or set the date.
- Adjust or set AM/PM.

### How to set up:

- Touch the screen on the box you wish to change.
- Change the number (increase/decrease) using the UP and DOWN buttons.
- Press OK to set the changes.

## Set Company Name / Beeper / Auto Dim

To set company name click on the BASIC icon and then on 'Display'.

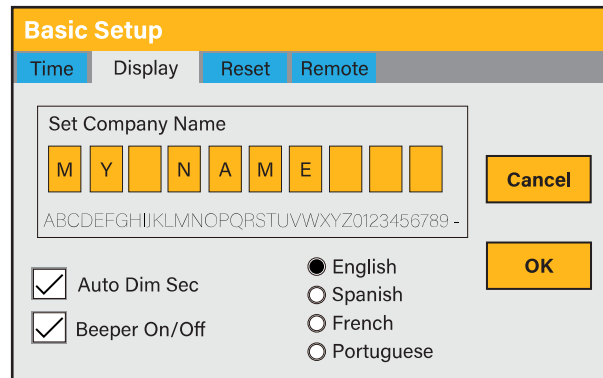

The screenshot shows the 'Basic Setup' menu with four tabs: 'Time', 'Display', 'Reset', and 'Remote'. The 'Display' tab is selected. Below the tabs is a 'Set Company Name' section with a grid of 10 yellow boxes containing the letters 'M', 'Y', 'N', 'A', 'M', 'E', and three empty boxes. Below the grid is a keyboard layout 'ABCDEFGHIJKLMNOPQRSTUVWXYZ0123456789 -'. To the right of the grid are 'Cancel' and 'OK' buttons. Below the grid are two checkboxes: 'Auto Dim Sec' (checked) and 'Beeper On/Off' (checked). To the right of these are four radio buttons for language selection: 'English' (selected), 'Spanish', 'French', and 'Portuguese'.

### What this page displays:

- Beeper status (ON/OFF): Allows you to toggle the beeper sound on or off for notifications.
- Installers' names: Option to enter and display the name of the installer for easier identification.

### What you can do from this page:

- Set your company name: Customise the name that appears on the display.
- Switch the beeper ON/OFF: Enable or disable the beeping sound for alerts.
- Set the LCD backlight to auto dim: Adjust the time delay for the screen to automatically dim when inactive.

### How to change the name:

- Touch the screen in each box where you wish to change the letter.
- Use the up and down arrows to change each letter.
- After selecting the desired name, press OK to update and save the new company name that will appear on the home screen.

### How to set the auto dim:

- Check or uncheck the Auto Dim Sec box, then press OK to configure as per your preference.
- This helps conserve energy and prolong the lifespan of the screen.

### How to turn the beep on or off:

- Check or uncheck the Beep On box, then press OK to configure as per your preference.
- When the beeper is on, the system will provide audible alerts for notifications and warnings.

## Factory Reset and Lock Code

To access the Settings, click on the gear icon on the right top of the menu.

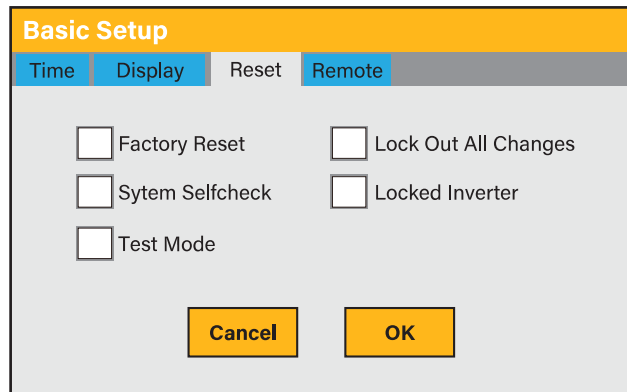

### What this page displays:

- **Factory Reset:** Resets all parameters of the inverter to their factory defaults. This will restore the inverter to its original settings. Before performing a factory reset, you must enter the password. The password for the factory reset is 9999.
- **Lock Out All Changes:** Enables the setting of parameters before locking the unit. Once locked, the inverter cannot be reset or reconfigured unless the correct password is provided. The password for locking the inverter is 7777.
- **System Selfcheck:** This allows the user to run a diagnostic on the system. After ticking this option, the password must be entered (default password: 1234) to proceed.
- **Locked Inverter:** When activated, this function locks the inverter completely, preventing any changes or configurations. It requires a 5-digit code, which is only available through Sunsynk's technical support team. This ensures secure operation.
- **Test Mode (for Engineers):** This mode is designed for engineers to conduct tests on the inverter, often used during troubleshooting or when performing specific diagnostic checks.

### What you can do from this page:

- Reset the inverter to the factory settings.
- Perform system diagnostics to check the operational health of the inverter.
- Change or set the lock code to prevent unauthorised access.

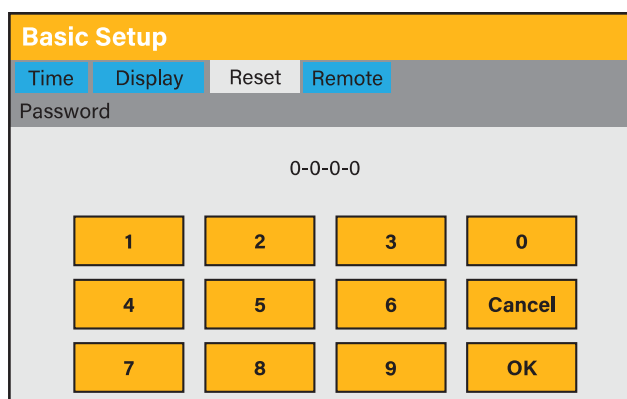

## Inverter Remote Control

To control the inverter remotely, tick the box that allows it.

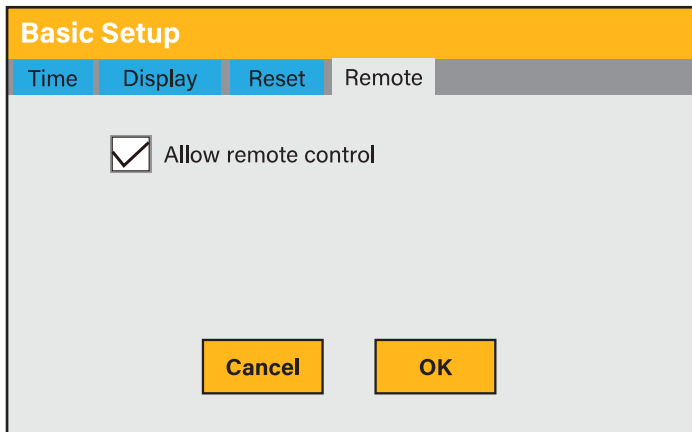

The screenshot shows the 'Basic Setup' page with a yellow header. Below the header are four tabs: 'Time', 'Display', 'Reset', and 'Remote'. The 'Remote' tab is selected and highlighted in grey. Below the tabs, there is a checkbox labeled 'Allow remote control' which is checked. At the bottom of the page, there are two yellow buttons: 'Cancel' and 'OK'.

### What this page displays:

- Remote control option: The setting that allows or disables remote control.

### What you can do from this page:

- Allows remote control of the inverter: Tick the box to enable remote control functionality. This feature allows you to control the inverter from a remote location, providing flexibility and ease of operation.

## Battery Setup Page

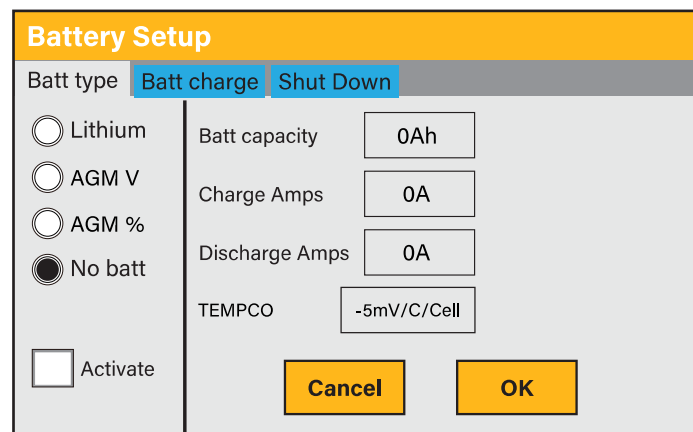

The screenshot shows the 'Battery Setup' page with a yellow header. Below the header are three tabs: 'Batt type', 'Batt charge', and 'Shut Down'. The 'Batt type' tab is selected and highlighted in grey. Below the tabs, there are four radio button options: 'Lithium', 'AGM V', 'AGM %', and 'No batt'. The 'No batt' option is selected. Below these options is a checkbox labeled 'Activate' which is unchecked. To the right of the radio buttons, there are four input fields: 'Batt capacity' (0Ah), 'Charge Amps' (0A), 'Discharge Amps' (0A), and 'TEMPCO' (-5mV/C/Cell). At the bottom of the page, there are two yellow buttons: 'Cancel' and 'OK'.

To configure battery settings:

1. Press the BATTERY icon.
2. Select the Batt type tab.

### BATTERY TYPE OPTIONS

- Lithium: For BMS-enabled lithium batteries. Always refer to the Approved Battery List.
- AGM V: Uses voltage values to control charging behaviour.
- AGM %: Uses State of Charge (SOC) as the control method.
- AGM V + %: Combines both voltage and SOC monitoring.
- No batt: Tick this box if no battery is connected. The inverter will operate in grid-tied mode using only solar or grid input.

### KEY DISPLAY VALUES

- Batt capacity (Ah): Enter battery capacity. Range is 0–2000Ah for non-BMS batteries. For lithium batteries, the inverter reads this from the BMS.
- Charge/Discharge Amps: Maximum battery charge and discharge current.
  - Max: 90A for 3.6kW model
  - Max: 120A for 5kW model
  - Max: 175A for 7kW model
- Active battery: Enables recovery charging for batteries that are 100% discharged. Slowly recharges using solar input until the voltage is high enough to charge normally.
- TEMPCO: The temperature coefficient (in V/°C/cell). Adjust only if advised by the battery manufacturer.



## NOTICE

### Recommended:

AGM and Flooded: Ah battery size x 20% = Charge/Discharge amps.

Lithium: Ah battery size x 50% = Charge/Discharge amps.

Gel: Follow manufacturer's instructions.

## Generator & Battery Charge Page

To configure generator charging:

1. Press the BATTERY icon.
2. Select the Batt charge tab.

### CHARGING SOURCE OPTIONS

- Amps: Charging current from the generator.
- Grid Amps: Charging current from the grid.
- Grid Charge: Tick to allow the grid to charge the battery.
- Grid Signal: Tick to stop grid charging when not needed.

### GENERATOR CONTROL OPTIONS

- Gen Charge: Enables charging from the generator when connected.
- Gen Signal: A normally open (NO) dry contact that closes when Gen Start is activated.
- Gen Force: Forces the generator to start immediately, bypassing conditions.
- Force OFF: Forces the generator to shut down.

### ISLAND MODE SETTINGS

- Signal ISLAND MODE. When enabled:
  - If the inverter is connected to the grid, the ATS port voltage is 0V.
  - If the inverter is disconnected from the grid, the ATS port voltage outputs 230V AC.
  - This function allows automatic management of neutral-earth bonding using an external NO relay.

### BATTERY VOLTAGE SETTINGS

- Float V: Voltage maintained after a full charge. (AGM Float Voltage: 55.20V)
- Absorption V: Max charging voltage during bulk charge. (AGM Absorption Voltage: 57.60V)
- Equalization V: Applies a controlled overcharge to remove sulphation. (AGM Equalisation Voltage: 58.80V)

To ensure safe battery operation and compatibility, use the correct voltage settings for each battery type. Incorrect configuration may result in reduced battery lifespan or performance.



## NOTICE

Do not alter these settings too often on the same battery, as it may damage the battery.

### Recommended Battery Settings

Battery Type	Absorption Stage	Float Stage	Voltage (every 30 days 3hr)
AGM (or PCC)	14.2V (57.6V)	13.4V (53.6V)	14.2V (57.6V)
Gel	14.1V (56.4V)	13.5V (54.0V)	
Wet	14.7V (59.0V)	13.7V (55.0V)	14.7V (59.0V)
Lithium	Follow its BMS voltage parameters		

## Generator Connection & Auto Start

A generator may be connected to either of the following:

- The Grid Input: The inverter treats generator input as grid power. Important: In this case, ensure that all power is used for Load only and is not exported, as this could damage the generator.
- The GEN port: When a GEN signal is received, the inverter will:
  - Switch 100% of the load to the generator.
  - Gradually begin charging the battery.



## WARNING

The generator must be capable of supplying both the load current and battery charging current simultaneously.

## Generator Start Signal (Dry Contact)

The inverter can control a generator using a dry contact relay. This signal:

- Is voltage-free (no output voltage).
- Supports up to 1A at 12V DC.
- Can be used to trigger the generator's auto-start system.

## Generator Auto-Start Circuit

Below is a reference diagram of a typical generator auto-start system used in marine and off-grid installations. The inverter activates relays to manage the switch-over between generator and load/grid connection.

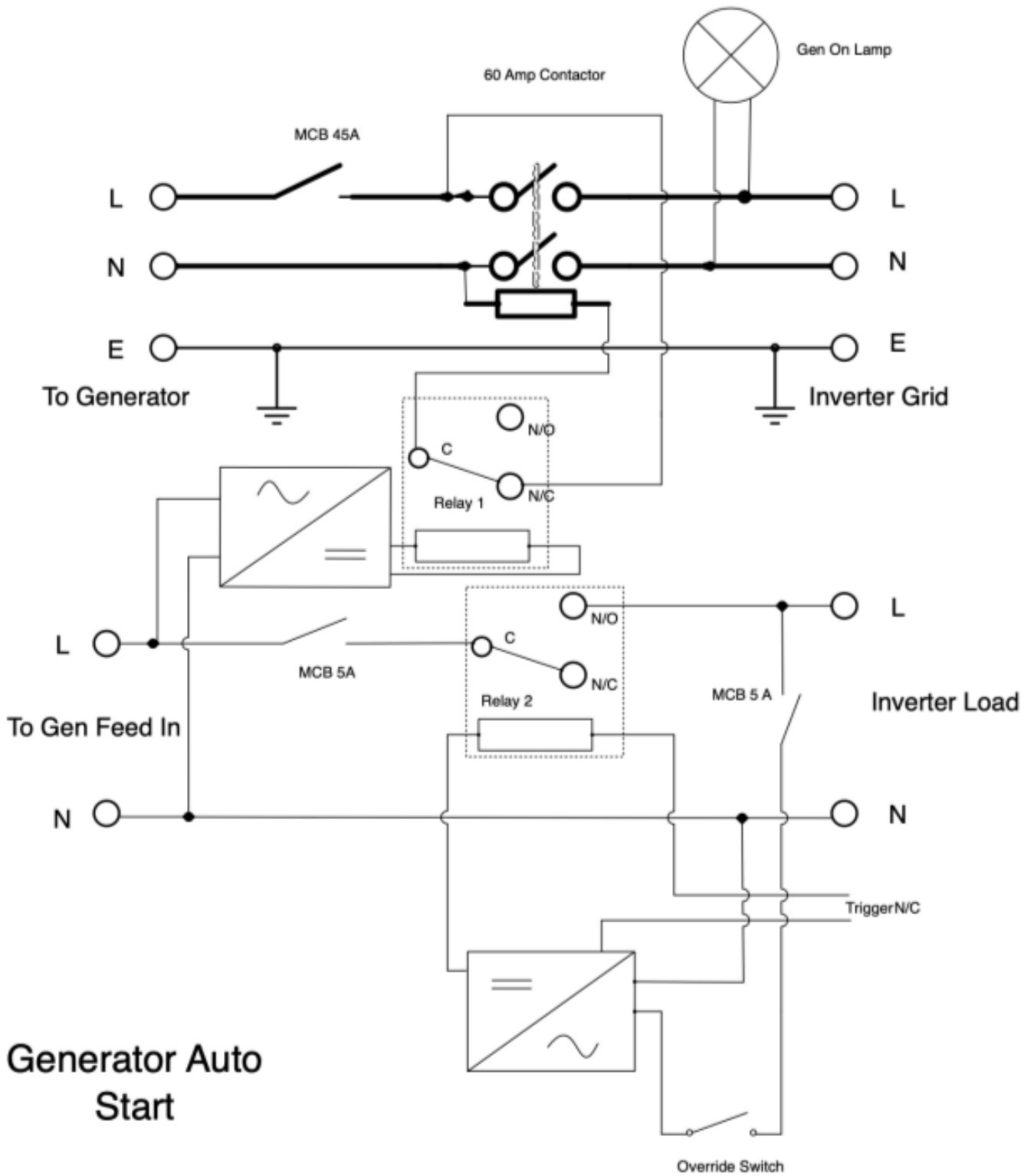

## Generator Auto Start

# Battery Discharge Page

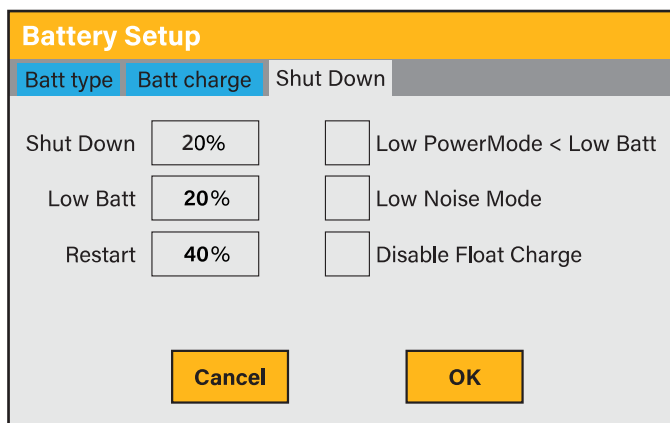

To configure inverter shutdown behaviour based on battery status:

1. Tap the BATTERY icon.
2. Select the "Shut Down" tab.

### What This Page Displays:

- Shutdown 20%: The inverter will automatically shut down if the battery SOC (State of Charge) drops below 20%.
- Low Batt 20%: Triggers a low battery warning alarm when SOC falls below this threshold.
- Restart 40%: When the battery SOC recovers to 40%, AC output will resume automatically.

### What You Can Do From This Page:

- Adjust battery shutdown point (voltage or %).
- Adjust low battery warning threshold.
- Set the restart threshold after shutdown.



### WARNING

If using an external RCD, its rated residual current must be at least 300 mA. Lower-rated RCDs may trip unnecessarily due to inverter switching characteristics.

The Sunsynk inverter displays different voltage values depending on whether the system is charging or discharging the batteries. Since the batteries are 48V, multiply each value below by 4 to understand full pack behaviour.

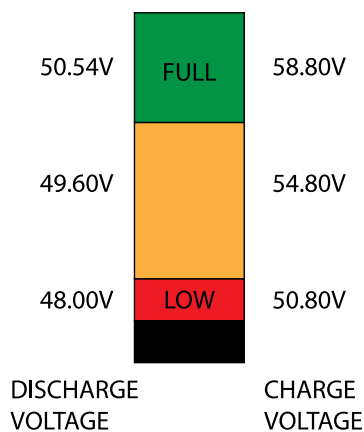

State of Charge	Discharge Mode Voltage	Charge Mode Voltage
100% (Fully Charged)	50.54V	58.80V
75% Charged	49.60V	54.80V
25% Charged	48.00V	50.80V
0% (Fully Discharged)	47.50V	—

### RECOMMENDED BATTERY TYPES

Sunsynk hybrid inverters are compatible with both AGM Lead-Acid and Lithium-Ion battery banks.

AGM (Absorbent Glass Mat) batteries are sealed lead-acid batteries. Instead of allowing the battery acid to flow freely, they use a fibreglass mat between the positive and negative plates to absorb and hold the electrolyte. This design improves safety, reduces maintenance, and supports deeper discharge cycles compared to traditional lead-acid batteries.

Lithium-Ion batteries offer higher energy density, longer cycle life, and integrated Battery Management Systems (BMS) for smarter, more efficient charging. When using lithium, the inverter will follow the BMS's voltage and current profiles automatically.

## BATTERY CHARGING STAGES

The inverter supports standard three-stage charging (plus optional equalisation for flooded lead-acid batteries):

### 1. Bulk charging:

- This is the first stage of charging.
- The charger applies maximum current to the battery until it reaches approximately 80% state of charge (SOC).
- The voltage gradually increases to the absorption level.
- A properly sized charger delivers current up to 25% of the battery's amp-hour capacity.

### 2. Absorption charging:

- Begins once the battery reaches ~80% SOC.
- The charger holds a constant high voltage (typically between 14.1–14.8 VDC, depending on settings).
- Charging current gradually decreases until the battery is nearly full.
- This stage completes the remaining ~20% of the charge.

### 3. Float charging:

- The voltage is reduced to between 13.0–13.8 VDC and held steady.
- The current is reduced to less than 1% of the battery capacity.
- Maintains the battery at 100% SOC without overcharging.
- Suitable for standby and long-term maintenance charging.

### 4. Equalisation (lead-acid only):

- An optional controlled overcharge used to balance the cells in flooded (wet) batteries.
- Raises the voltage above normal charging levels to re-mix stratified electrolyte and remove sulphation from the plates.
- Only recommended for specific lead-acid batteries and not suitable for sealed AGM or lithium unless explicitly supported by the manufacturer.

## Setting Up a Lithium Battery

The screenshot shows the 'Battery Setup' menu with three tabs: 'Batt type', 'Batt charge', and 'Shut Down'. The 'Batt type' tab is active. Under 'Batt type', there are four radio button options: 'Lithium' (selected), 'AGM V', 'AGM %', and 'No batt'. Below these is an 'Activate' checkbox. To the right, there are input fields for 'Batt capacity' (0Ah), 'Charge Amps' (0A), and 'Discharge Amps' (0A). Further right, there are two radio button options: 'CAN' (selected) and 'RS485'. Below these is a 'Protocol' field with the value '0' and a 'BMS\_Err\_Stop' checkbox. At the bottom, there are 'Cancel' and 'OK' buttons.

To configure a lithium-ion battery:

1. Press the BATTERY icon.
2. Select Lithium under the Batt Type menu.

### What This Page Displays:

- Lithium battery setup and protocol selection.
- Charging/discharging current limits.
- Battery capacity (for non-BMS batteries).
- Activation setting.
- RS485 or CAN communication protocol.

### What You Can Do From This Page:

- Configure lithium BMS communication.
- After installing a lithium battery, verify the connection by selecting the 'Li BMS' icon on the inverter's display. This page should show live battery data including voltage, current, temperature, and state of charge. If the data does not appear or displays incorrectly (see reference example below), it indicates a communication error.



### NOTICE

Some lithium batteries cannot be controlled directly by the Sunsynk inverter via BMS. If communication is not possible:

1. Treat the battery as a lead-acid battery in the inverter settings.
2. Manually configure the charging and discharging values based on the battery manufacturer's recommendations.

Li BMS		Help ?
Sum Data	Details Data	
Battery Voltage: 53.06V		
Battery Current: -1A		
Battery Temp: 22.0C		
Total SOC: 85%		
Total SOH: 100%		
Battery Chage Voltage: 58.0V		
Charge Current Limit: 50A		
Discharge Current Limit: 50A		

Li BMS							Help ?	
Sum Data				Details Data				
	Volt	Curr	Tem	SOC	Energy	Charge		
						Volt	Curr	Fault
1	50.31V	19.70A	29.6C	33.0%	26.0Ah	0.0V	0.0A	0 0 0
2	50.38V	31.70A	37.6C	51.0%	25.5Ah	53.2V	25.0A	0 0 0
3	50.35V	25.10A	29.9C	52.0%	6.0Ah	53.2V	25.0A	0 0 0
4	50.37V	30.70A	32.1C	12.0%	26.0Ah	0.0V	0.0A	0 0 0
5	50.35V	00.00A	30.6C	48.0%	32.0Ah	0.0V	0.0A	0 0 0
6	50.36V	15.40A	30.6C	52.0%	39.1Ah	0.0V	0.0A	0 0 0
7	00.00V	00.00A	0.0C	00.0%	00.0Ah	0.0V	0.0A	0 0 0
8	50.38V	19.30A	31.0C	52.0%	25.5Ah	0.0V	0.0A	0 0 0
9	50.39V	16.30A	30.6C	52.0%	26.0Ah	0.0V	0.0A	0 0 0
10	00.00V	00.00A	0.0C	00.0%	00.0Ah	0.0V	0.0A	0 0 0
11	00.00V	00.00A	0.0C	00.0%	00.0Ah	0.0V	0.0A	0 0 0
12	00.00V	00.00A	0.0C	00.0%	00.0Ah	0.0V	0.0A	0 0 0
13	00.00V	00.00A	0.0C	00.0%	00.0Ah	0.0V	0.0A	0 0 0
14	00.00V	00.00A	0.0C	00.0%	00.0Ah	0.0V	0.0A	0 0 0
15	00.00V	00.00A	0.0C	00.0%	00.0Ah	0.0V	0.0A	0 0 0

### In Case of Communication Errors:

- Ensure the data cable is the correct type (e.g. RS485 or CAN, depending on the battery).
- Check that the cable is firmly connected to the correct communication port.
- Refer to the battery manufacturer's manual for communication protocol, pin configuration, and setup values.



## NOTICE

If the inverter does not communicate with the battery, do not overcharge the battery bank. Many lithium batteries have a current limit of 100A. Some are rated lower, and others higher. Always follow the voltage and current ratings provided by the battery manufacturer.

If you are using lead-acid batteries, use the following guideline:

- Maximum charge or discharge current = Battery Ah × 0.25
- Example: A 200Ah battery array composed of 4 × 200Ah batteries in series has a maximum discharge of only 50Ah (200 × 0.25 = 50)

Also, make sure:

- The cable size is suitable for the required current.
- The fuses are rated correctly according to the battery manufacturer's recommendation.

## System Work Mode Setup Menu

Real Start Time

Real End Time

Power Limit

Battery % or voltage when an action is to happen

Charge from Grid  
Charge from Gen  
No tick = Discharge

User Controller

System Mode

System 1 System 2

Fast\_Zero\_Export\_Mode

Zero Export

Solar Export

Limit to Load Only

20W Grid Trickle Feed

8000W Inverter Power Limiter

Priority Load

Cancel

OK

Cancel

OK

1

2

3

4

5

6

Time Start	Time End	Power	SOC/V	Grid	Gen
01:00	05:00	8000	100%	<input checked="" type="checkbox"/>	<input checked="" type="checkbox"/>
05:00	09:00	8000	100%	<input checked="" type="checkbox"/>	<input checked="" type="checkbox"/>
09:00	13:00	8000	100%	<input checked="" type="checkbox"/>	<input checked="" type="checkbox"/>
13:00	17:00	8000	100%	<input checked="" type="checkbox"/>	<input checked="" type="checkbox"/>
17:00	21:00	8000	100%	<input checked="" type="checkbox"/>	<input checked="" type="checkbox"/>
21:00	01:00	8000	100%	<input checked="" type="checkbox"/>	<input checked="" type="checkbox"/>

To configure charge and discharge time settings, click on the System Mode icon, then select the gear icon to access the timer settings.

### What this page displays:

- Zero Export:** Select this option to prevent power from being exported back to the grid. The CT coil detects power flowing back to the grid and will reduce the inverter's output to only supply local load.
- Solar Export:** Enable this setting to export surplus solar power to the grid.
- Limit to Load Only:** Enable this to ensure the inverter only supplies power to the connected load, preventing export to the grid.
- Grid Trickle Feed:** Set the range from '20W' to '100W' to instruct the inverter to take a minimal amount of power from the grid, reducing the likelihood of triggering the 'Reverse Power Detection' on sensitive pre-paid meters.
- Inverter Power Limiter:** Limits the total output power from the inverter to both the 'Load' and 'Grid' ports combined. This setting reduces power in the event of an over-current fault.
- Priority Load:** Enable this to prioritise supplying power to the connected load from solar energy. If disabled, the solar power will be used to charge the batteries.

### What you can do from this page:

- Set a specific time to start and stop charging or discharging the battery.
- Select the charging source: Choose between the grid or a generator to charge the battery.
- Limit export power to the grid.
- Charge from the grid or generator: Tick 'Grid' or 'Gen' and set the desired times for charging.
- Set the discharge time: Discharge the unit to the load or export to the grid by unticking 'Grid' and 'Gen'.

### If nothing is ticked:

This mode allows the hybrid inverter to sell back any excess power generated by the solar panels to the grid. If the use time is active, the energy from the battery can also be sold to the grid. The PV energy will be used to power the load and charge the battery, with any surplus energy flowing to the grid. The power source priority for the load is:

- Solar Panels
- Grid
- Batteries (until the programmable % discharge is reached)

### ZERO EXPORT + LIMIT TO LOAD ONLY:

In this mode, the Sunsynk hybrid inverter supplies power exclusively to the connected backup loads. It will not provide energy to any other household loads, nor will it export power back to the grid. The built-in current transformer (CT) continuously monitors any power flowing from the inverter to the grid. If reverse power is detected, the CT will automatically adjust the inverter's output to ensure that only the local load is supplied and that the battery continues to charge.

- Function: Prevents power export to the grid while ensuring that the backup loads are powered.
- CT role: Ensures no power is exported to the grid by dynamically adjusting the inverter's output.

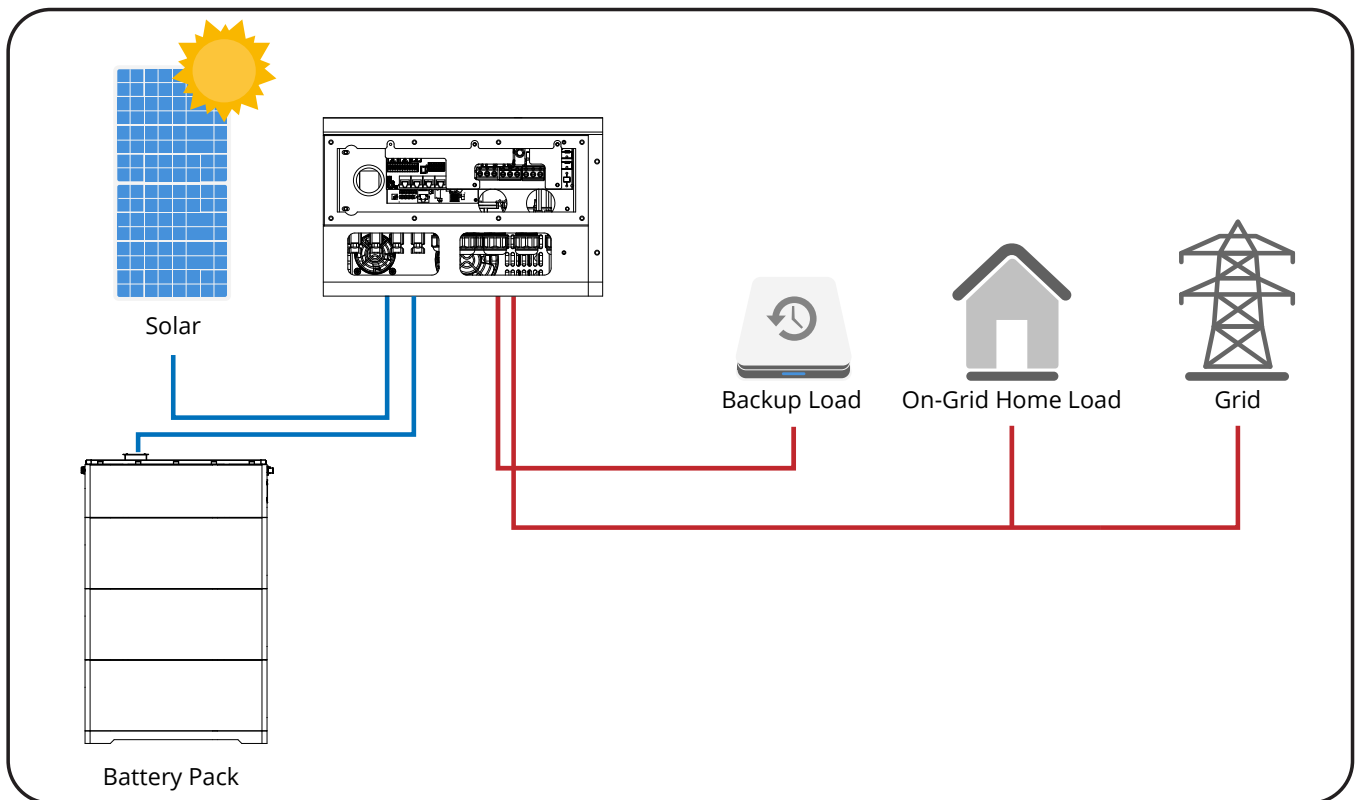

### ZERO EXPORT TO CT:

This mode enables the inverter to supply power not only to the backup loads but also to the household loads. In the event that the combined power from the solar and battery is insufficient to meet the household's demand, the grid will provide supplemental power. However, no power will be exported to the grid under any circumstances.

- CT requirement: A current transformer (CT) is necessary for proper operation. The CT will detect grid-bound power and modify the inverter's output accordingly.
- System adjustment: When the CT detects power flowing to the grid, it reduces the inverter's output to match the local load requirements and continue charging the battery.
- Configuration: Please refer to the "CT Connection" section for detailed installation instructions to ensure accurate CT integration.

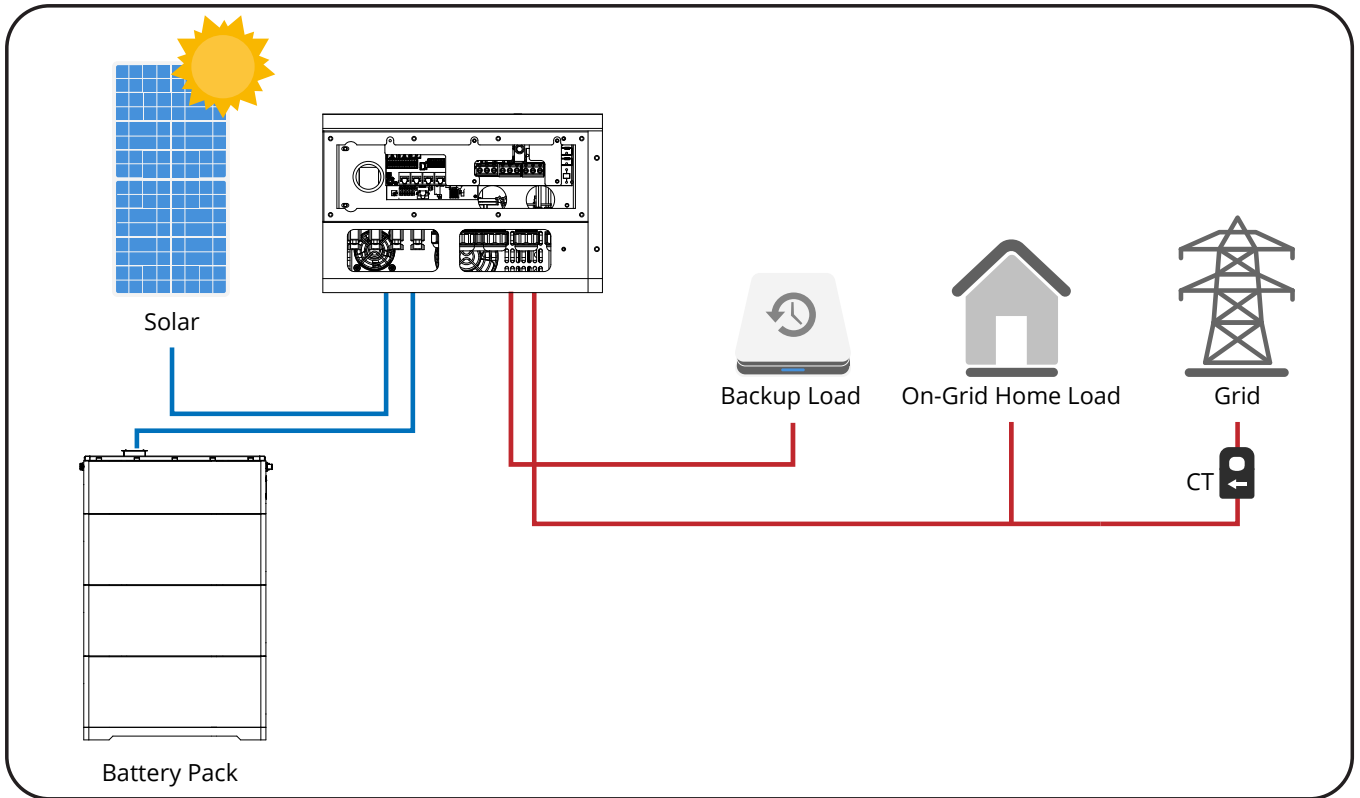

**Example 1:**

From 8 a.m. to 11 a.m., the battery is charged to 100% using both solar PV and grid power. After reaching full charge, the system supplies up to 4 kW of power to essential loads via the Load Port until the battery's state of charge (SOC) drops to 50%.

**System Mode**

System 1 | **System 2**

Time Start	Time End	Power	SOC/V	Grid	Gen
08:00	11:00	4000	100%	<input checked="" type="checkbox"/>	<input type="checkbox"/>
<input type="text"/>	<input type="text"/>	<input type="text"/>	<input type="text"/>	<input type="checkbox"/>	<input type="checkbox"/>
<input type="text"/>	<input type="text"/>	<input type="text"/>	<input type="text"/>	<input type="checkbox"/>	<input type="checkbox"/>
<input type="text"/>	<input type="text"/>	<input type="text"/>	<input type="text"/>	<input type="checkbox"/>	<input type="checkbox"/>
<input type="text"/>	<input type="text"/>	<input type="text"/>	<input type="text"/>	<input type="checkbox"/>	<input type="checkbox"/>
<input type="text"/>	<input type="text"/>	<input type="text"/>	<input type="text"/>	<input type="checkbox"/>	<input type="checkbox"/>

User Timer

**Cancel**

**OK**

**System Mode**

**System 1** | System 2

Fast\_Zero\_Export\_Mode

Zero Export  Priority Load

Solar Export

Limit to Load Only

Grid Trickle Feed

Inverter Power Limiter

**Cancel**

**OK**

**IMPORTANT** - When charging the batteries from the grid or generator, ensure the correct battery charge settings are applied, as detailed in the "Battery Setup" section. If the 'Use Timer' function is enabled, the inverter will follow the preset timings for using battery power when grid power is available. Without this setting, batteries will only be used when there is no grid power available.

**Example 2:**

The export limit for feeding power back to the grid is governed by the inverter's configured power limiter setting. When the "Solar Export" feature is enabled, any surplus solar energy produced after the batteries are fully charged and the load requirements are met is exported to the grid. It should be noted that the 100W grid trickle feed is independent of the export limit and does not influence or determine the export value.

**System Mode**

System 1 **System 2**

Time Start	Time End	Power	SOC/V	Grid	Gen

User Timer

**Cancel**

**OK**

**System Mode**

System 1 **System 2**

Fast\_Zero\_Export\_Mode

Zero Export  Priority Load

Solar Export

Limit to Load Only

100W Grid Trickle Feed

8000W Inverter Power Limiter

**Cancel**

**OK**

**System Mode**

System 1 **System 2**

Time Start	Time End	Power	SOC/V	Grid	Gen
01:00	05:00	5000	80%	<input checked="" type="checkbox"/>	<input type="checkbox"/>
05:00	08:00	5000	40%	<input type="checkbox"/>	<input type="checkbox"/>
08:00	10:00	5000	40%	<input type="checkbox"/>	<input type="checkbox"/>
10:00	15:00	5000	80%	<input type="checkbox"/>	<input type="checkbox"/>
15:00	18:00	5000	40%	<input type="checkbox"/>	<input type="checkbox"/>
18:00	01:00	5000	35%	<input type="checkbox"/>	<input type="checkbox"/>

User Timer

**Cancel**

**OK**

**Example:**

During 01:00-05:00, when the battery SOC is lower than 80%, it will use the grid to charge the battery until the battery SOC reaches 80%.

During 05:00-08:00 and 08:00-10:00, when battery SOC is higher than 40%, the hybrid inverter will discharge the battery until the SOC reaches 40%.

During 10:00-15:00, when the battery SOC is higher than 80%, the hybrid inverter will discharge the battery until the SOC reaches 80%.

During 15:00-18:00, when the battery SOC is higher than 40%, the hybrid inverter will discharge the battery until the SOC reaches 40%.

During 18:00-01:00, when the battery SOC is higher than 35%, the hybrid inverter will discharge the battery until the SOC reaches 35%.

**Grid Supply Page**

**Grid Setup**

Grid Type **Connect** IP F(W) V(W) V(Q) P(Q) P(F)

Grid Mode  0/16

Grid Frequency  50Hz  60Hz

Grid Type  Single Phase  120/240V Split Phase  120/208V 3 Phase

Unlock Grid Settings

INV Output V(AC)

Export power limiter  Import power limiter

**Cancel**

**OK**

To configure the grid supply settings, click on the GRID icon in the Settings menu.

**What this page displays:**

- Grid Mode: Select the grid mode according to your local grid regulations (e.g., EN50549\_CZ\_PPDS\_LT6A, NR5097, G99/G99S). Choose the appropriate grid standard from the drop-down menu. If your local grid standard is not listed, please input the grid settings manually as per the instructions provided below.
  - **G100** - For compliance with G100 regulations, ensure that the inverter is set to G99/G100 (select this option when needed).
- Grid Frequency: This field indicates the required grid frequency (usually 50Hz or 60Hz depending on your region).
- Grid Type: Select the correct grid type based on your local requirements:
  - Single Phase
  - Split Phase
  - Three-Phase (if applicable)
- Unlock Grid Settings: By default, the inverter grid settings are locked for security. To modify these settings, click the "Unlock Grid Settings" option. You will be prompted to enter a password to gain access and make necessary changes to the grid parameters.
- Export power limiter: It is used to setup the allowed the maximum output power to flow to grid.
- Import power limiter: when it is active, the grid output power will be limited. its priority is lower then "grid peak shaving" if the "grid peak shaving" is selected.

**What this page displays:**

- Normal connect: Defines the allowed grid voltage/frequency range when the inverter first connects to the grid.
- Normal Ramp rate: This is the rate at which the inverter ramps up to the grid voltage. The ramp rate helps prevent damage to the inverter or grid by ensuring a smooth transition to full operation.
- Reconnect after trip: Defines the allowed grid voltage/frequency range when the inverter reconnects to the grid after a disconnect.
- Reconnect Ramp Rate: Sets the rate at which the inverter reconnects to the grid after a disconnect.
- Reconnection Time: Defines the waiting period for the inverter before attempting to reconnect to the grid after a disconnect event.
- Power Factor: This parameter allows the inverter to adjust its reactive power output to match the grid's requirements, ensuring efficient grid integration.

Grid Setup							
Grid Type	Connect	IP	F(W)	V(W)	V(Q)	P(Q)	P(F)
Over voltage U.(10min. running mean) 260.0V							
HV3	265.0V		HF3	51.50Hz			
HV2	265.0V	-- 0.10s	HF2	51.50Hz	-- 0.10s		
HV1	265.0V	-- 0.10s	HF1	51.50Hz	-- 0.10s		
LV1	185.0V	-- 0.10s	LF1	48.00Hz	-- 0.10s		
LV2	185.0V	-- 0.10s	LF2	48.00Hz	-- 0.10s		
LV3	185.0V		LF3	48.00Hz			

### What this page displays:

- HV1: Level 1 overvoltage protection point;
- HV2: Level 2 overvoltage protection point;
- HV3: Level 3 overvoltage protection point.
- LV1: Level 1 undervoltage protection point;
- LV2: Level 2 undervoltage protection point;
- LV3: Level 3 undervoltage protection point.
- HF1: Level 1 over frequency protection point;
- HF2: Level 2 over frequency protection point;
- HF3: Level 3 over frequency protection point.
- LF1: Level 1 under frequency protection point;
- LF2: Level 2 under frequency protection point;
- LF3: Level 3 under frequency protection point;
- 0.10s: Trip time.

### What you can do from this page:

- Set voltage protection points:
  - Over-voltage protection (HV): Set the protection thresholds for over-voltage conditions. The inverter will disconnect from the grid if the grid voltage exceeds these thresholds.
  - Under-voltage protection (LV): Set the protection thresholds for under-voltage conditions. The inverter will disconnect from the grid if the grid voltage falls below these values.
- Frequency protection:
  - Over-frequency protection (HF): Set the protection thresholds for over-frequency conditions. The inverter will disconnect if the frequency exceeds the set limits.
  - Under-frequency protection (LF): Set the protection thresholds for under-frequency conditions. The inverter will disconnect if the frequency falls below these values.
- Trip time: Adjust the trip time to determine how quickly the inverter disconnects after the overvoltage, undervoltage, over-frequency, or under-frequency conditions are detected. The default trip time is 0.10 seconds.

### Example:

- Over-voltage (HV1 set to 265.0V, HV2 set to 265.0V, HV3 set to 265.0V): The inverter will disconnect from the grid if the voltage exceeds 265.0V for a duration greater than the set trip time.
- Under-voltage (LV1 set to 185.0V, LV2 set to 185.0V, LV3 set to 185.0V): The inverter will disconnect if the voltage drops below 185.0V.

### What this page displays:

- **FW:** This series inverter is able to adjust inverter output power according to grid frequency.
- **Droop f:** The percentage of nominal power per Hz.

### Frequency Settings:

- Over Frequency:
  - Start freq f: The frequency at which the inverter begins reducing output.
  - Stop freq f: The frequency where the inverter stops reducing power.
  - Start delay f: The time before starting power reduction.
- Under Frequency:
  - Start freq f: The lower frequency at which power reduction starts.
  - Stop freq f: The frequency at which power reduction stops.
  - Start delay f: Delay before initiating power reduction.

### What you can do from this page:

- Adjust frequency settings: Set the start and stop frequencies to determine at which grid frequency the inverter will reduce its power output.
- Set Droop f: Configure the inverter's response to frequency changes. For example, setting a higher percentage means the inverter will reduce power more aggressively as the frequency deviates from the nominal value.
- Control grid frequency response: Fine-tune the inverter's sensitivity to frequency fluctuations, ensuring it reacts appropriately in various grid conditions.

### Example:

- Over-frequency (Start frequency: 50.2Hz, Stop frequency: 50.0Hz, Droop f: 40% PE/Hz): In this case, when the grid frequency reaches 50.2Hz, the inverter will start to reduce its output power at a rate of 40% for each Hz drop. When the grid frequency reaches 50.0Hz, the inverter will stop reducing its output power.
- Under-frequency (Start frequency: 48.0Hz, Stop frequency: 48.0Hz, Droop f: 40% PE/Hz): This will cause the inverter to decrease power if the grid frequency drops below 48.0Hz.

Grid Type	Connect	IP	F(W)	V(W)	V(Q)	P(Q)	P(F)
<input type="checkbox"/>	V(W)	<input type="checkbox"/>	V(Q)				
			Lin: 20.0%	Lout: 5.0%			
V1	109.0%	P1	100%	V1	90.0%	Q1	44%
V2	110.0%	P2	20%	V2	95.7%	Q2	0%
V3	111.0%	P3	20%	V3	104.3%	Q3	0%
V4	111.0%	P4	20%	V4	112.2%	Q4	-60%

**What this page displays:**

- V(W): This adjusts the inverter’s active power based on the set grid voltage.
- V(Q): This adjusts the inverter’s reactive power according to the grid voltage. It modifies both the active and reactive output power when grid voltage changes.
- Lock-in/Pn 5%: This condition applies when the inverter's active power is less than 5% of the rated power. In such cases, the VQ mode will not activate.
- Lock-out/Pn 20%: If the inverter’s active power rises above 20% of the rated power, the VQ mode will not take effect.

**Examples:**

- V2 = 110%, P2 = 20%: When the grid voltage reaches 110% of the rated grid voltage, the inverter’s output power will decrease to 20% of the rated power.
- V1 = 90%, Q1 = 44%: When the grid voltage reaches 90% of the rated grid voltage, the inverter output will produce 44% of reactive power.

Grid Type	Connect	IP	F(W)	V(W)	V(Q)	P(Q)	P(F)
<input type="checkbox"/>	P(Q)	<input type="checkbox"/>	P(F)				
			Lin: 404.3%	Lout: 646.9%			
P1	0%	Q1	0%	P1	0%	F1	-2,400
P2	0%	Q2	0%	P2	0%	F2	0,000
P3	0%	Q3	0%	P3	0%	F3	0,000
P4	0%	Q4	0%	P4	0%	F4	6,000

**What this page displays:**

- P(Q): It adjusts the inverter reactive power according to the set active power.
- P(PF): It adjusts the inverter PF according to the set active power.
- Lock-in/Pn 50%: When the inverter output active power is less than 50% of the rated power, it will not enter the P(PF) mode.
- Lock-out/Pn 50%: When the inverter output active power is higher than 50% of the rated power, it will enter the P(PF) mode.



**NOTICE**

The P(PF) mode will only take effect when the grid voltage is equal to or greater than 1.05 times the rated grid voltage.

# Advanced Functions

## Multi-Inverter

The screenshot shows a configuration window titled 'ADVANCE' with a yellow header. Below the header are four tabs: 'Multi-Inverter', 'Others', 'P-Shave', and 'Wind Turbine'. The 'Multi-Inverter' tab is selected. The configuration options include: a checkbox for 'Parallel', radio buttons for 'Master' and 'Slave', a text input field for 'Modbus SN', and radio buttons for 'Phase A', 'Phase B', and 'Phase C'. There are also checkboxes for 'Ex\_Meter for CT' and 'Grid Tie Meter2'. A 'Meter Select' dropdown menu is set to 'No Meter' with '0/4' next to it. At the bottom of the window are two buttons: 'Cancel' and 'OK'.

To configure multi-inverter settings, click on the ADVANCE icon.

### What this page displays:

- Master/Slave selection: This option allows you to designate whether the inverter operates as a master or a slave.
- Modbus Device ID: The 'Modbus SN' must be unique for each inverter connected to the bus/wire.
- Ex\_Meter for CT: In a three-phase system with a CHiNT Three-phase energy meter (DTSU666), select the corresponding phase where the hybrid inverter is connected (Phase A, B, or C).

### What you can do from this page:

- Set the inverter to operate as either a master or slave in the parallel configuration.
- Assign a Modbus SN to each inverter for proper paralleling.
- Specify the phase where the inverter will be connected in the parallel system (for three-phase systems).
- Choose the meter type based on the system setup.

### PARALLELING CONFIGURATION

The Sunsynk Parity inverter can be installed as a standalone unit or connected in parallel to provide more power. You can set up single-phase or three-phase configurations, depending on your system requirements.

#### Single-Phase Paralleling:

- Maximum inverters: Up to 16 inverters can be paralleled in a single-phase grid.
- Master-Slave Setup: One inverter will act as the master, while the remaining 15 will function as slaves.

#### Three-Phase Paralleling:

- Maximum inverters: Up to 15 inverters can be paralleled in a three-phase grid.
- Master-Slave Setup: Three inverters will act as masters (one per phase), and the remaining 12 will function as slaves.
  - Phase A: Master A + 4 Slaves A
  - Phase B: Master B + 4 Slaves B
  - Phase C: Master C + 4 Slaves C

In a three-phase system, the paralleled inverters will supply both single-phase (220V LN) and three-phase (380V LL) loads with proper phase rotation.

#### Stability and Wiring Considerations:

- All batteries must be connected in parallel per inverter.
- Minimum cable size: Use 50mm<sup>2</sup> diameter cables with fuse isolators for each inverter.

- Each inverter requires its own fuse isolator with surge protection, and each circuit must have an RCD.
- If using the battery backup during an outage, install a changeover switch or use a split load.

### Communication and Wiring:

- CT coils for limiting export power should only be connected to the master inverter. For six inverters in parallel, three CT coils are required.
- Use an RJ45 communication cable to connect inverters in parallel. The order does not matter as both sockets are identical.
- Each phase must have one master inverter, and each inverter must have a unique Modbus number.
- The maximum communication cable length should not exceed 2 meters.
- MPPTs must be kept separate for each inverter.

### Important Notes:

1. Firmware consistency: Ensure that all inverters in a parallel or three-phase system are running the same firmware version. It's recommended to request firmware updates for all inverters before configuring them in parallel.
2. Load breaker isolation: Each inverter in a parallel system must have its own isolating load breaker before it is connected to the parallel breaker. This ensures that the load outputs are isolated during programming.
3. Final connection: Only after confirming that all inverters are correctly programmed in parallel or three-phase configuration, can the isolating breakers be switched on. This then feeds into the main load output breaker.

When configuring a three-phase system using three single-phase inverters, ensure correct phase rotation (clockwise) to avoid miswiring.



### NOTICE

The communication cables have two specific ends: one for connecting to the BMS and another for connecting to the inverter. Do not swap these cables. If communication issues arise, check the settings and ensure the data cables are correctly connected.

Grid input can also be connected in parallel to accommodate multiple inverters.

### TROUBLESHOOTING AND FAQs FOR PARALLELING INVERTERS

For additional assistance, please visit the Sunsynk website at [www.sunsynk.com](http://www.sunsynk.com), where you will find training videos and Frequently Asked Questions (FAQs).

**Important:** Before installation, ensure that the firmware on all inverters is updated to the latest version. It is crucial that all inverters in parallel or in a three-phase system run the same firmware to avoid compatibility issues.

#### Q1: What is the sequence to install/connect/commission?

First of all, leave the main supplies off. Next, connect all communication cables, set up all LCDs and then, last of all, turn on the main supplies.

#### Q2: What are the indications that the communication and the system are OK or not?

Parallel errors will be shown as fault F46 on the display.

#### Q3: What are the consequences of not setting one inverter in a parallel mode?

It can damage the inverter.

#### Q4: What are the consequences of having more than one Master Inverter or having no inverter set as 'Master'?

It can damage the inverter. There are cases in which it is possible to have more than one master. For example, as aforementioned, six inverters paralleled in a three phase utility grid (three masters).

### Q5: What are the consequences for setting A, B, or C phases wrong while in parallel mode?

It can damage the inverter. Recommend checking the phase rotation with a meter before switching on.

### Q6: What are the consequences of factory resetting, power cycling, or firmware updating one inverter in a parallel system?

It can damage the inverter. Inverters need to be isolated from each other before factory reset or firmware update.

### Q7: What consequences for changing ALL/ANY settings while operating in parallel mode?

It can damage the inverter and fault F46 will be indicated on the display.

## Others

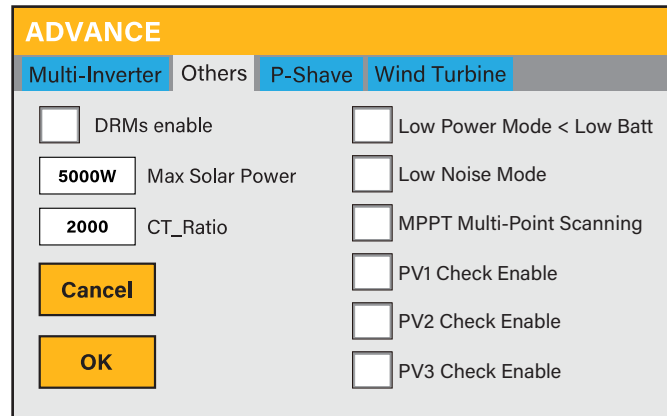

To access the advanced operational controls for the inverter, navigate to the following path:

### Settings → Advanced → Others

The following options are available for configuration:

- **DRMs Enable:** Activates Demand Response Mode (DRM) compliance. When an external DRM device is connected, the inverter responds to DRM control signals in accordance with AS/NZS 4777.2:2020.
- **Max Solar Power:** Defines the maximum PV DC power the inverter can accept and convert to AC output. This value limits the inverter's total solar generation capacity and serves as the primary control setting for the generation limit.
- **CT Ratio:** Sets the Current Transformer (CT) ratio when an external CT clamp is used for export power control. This ensures accurate measurement of site power flow between the inverter and the grid.
- **Low Power Mode < Low Batt:** Reduces inverter generation when battery voltage drops below the low-battery threshold. This is a protective feature that prevents deep discharge and prioritizes battery health.
- **Low Noise Mode:** Minimizes operational noise by reducing fan speed and switching frequency. While it does not affect generation limits, it may slightly reduce overall inverter efficiency.
- **MPPT Multi-Point Scanning:** Enables the inverter to periodically re-scan the PV array to maintain optimal Maximum Power Point (MPP) tracking. This is recommended to keep enabled for consistent PV performance.
- **PV1 Check Enable / PV2 Check Enable / PV3 Check Enable:** Enables or disables monitoring of each individual PV input (string). All should remain enabled during normal operation for system protection and monitoring accuracy.

## DRM CONNECTION

To configure and enable DRMs (Demand Response Management) functionality, you can access the related settings under the Advanced Settings menu.

### What this page displays:

- In the Advanced Settings menu, select DRMs Enable to activate DRM functionality.
- You can also configure the Max Solar Power and CT Ratio settings according to your system requirements.

Below is an example of how these options appear in the settings:

- 5000W: This sets the maximum solar power limit.
- 2000: Sets the CT ratio, which helps the inverter adjust power levels for the grid connection. Choose the meter type based on the system setup.
- Low Power Mode < Low Batt: When it's selected and battery SOC is less than "Low Batt" value, the self-consumption power of inverter will supply by grid and battery simultaneously. If unselected, the self-consumption power of inverter will supply by battery.
- Low Noise Mode: Changes the switching frequency of the internal IGBTs from 15kHz to 20kHz to reduce audible electrical noise. This prevents high-frequency sound that may be noticeable to users with sensitive hearing or in quiet environments.
- MPPT Multi-Point Scanning: The inverter will check whether the PV is working on its Max. power point. If not, then it will adjust the voltage of MPPT to ensure the PV operates at the Max. power point.

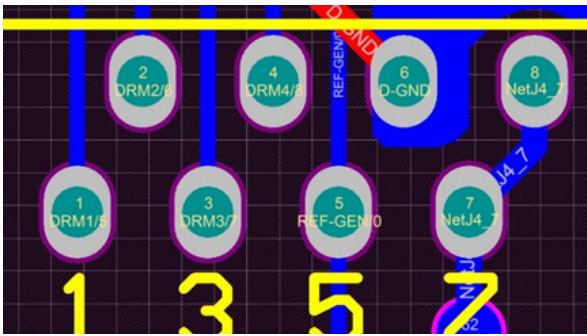

- |            |               |
|------------|---------------|
| 1. DRM 1/5 | 5. Ref 0      |
| 2. DRM 2/6 | 6. COM LOAD/0 |
| 3. DRM 3/7 | 7. Net J 4-7  |
| 4. DRM 4/8 | 8. Net J 4-7  |

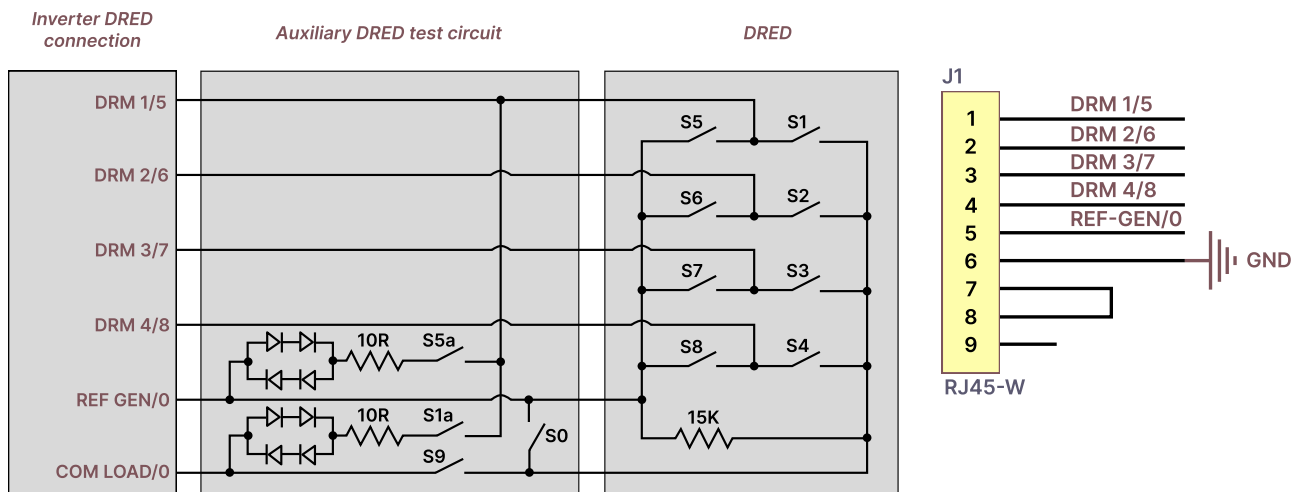

### GENERATION LIMIT CONTROL (MAX SOLAR POWER FUNCTION)

The inverter allows installers to configure generation limit control through the **Settings** → **Advanced** → **Others** menu.

This function manages the inverter's total solar generation by limiting or adjusting the maximum PV DC power that can be processed and converted to AC output. It enables compliance with site, grid, and system requirements while supporting efficient system operation.

The Max Solar Power parameter defines the inverter's generation limit control. The value entered specifies the highest PV DC input power that the inverter will accept and convert to AC output. Even if the PV array can produce more power, the inverter restricts its operation to the configured limit.

This feature ensures compliance with local regulations, prevents unwanted grid export, and helps balance on-site generation and consumption.

## Applications of Generation Control

Generation limit control can be used to:

- Comply with network export limits or constraints imposed by the utility or Distributed Network Service Provider (DNSP).
- Prevent grid export (zero-export operation) where site export is not permitted.
- Balance generation with on-site consumption to maintain stable system operation and prevent backfeeding.
- Coordinate solar generation with battery storage to avoid overcharging and optimize utilization.
- Support site load management during demand control or limited supply conditions.

When configured, the inverter dynamically regulates DC-to-AC conversion in real time, ensuring that solar generation remains within the defined Max Solar Power limit or is modulated according to CT feedback and grid conditions.

### Setting Up Generation Limit Control (Max Solar Power)

1. Access the Menu: Navigate to **Settings** → **Advanced** → **Others**.
2. Set Maximum Generation Limit:
  - In the Max Solar Power field, enter the desired maximum solar generation value (e.g., 5000 W).
  - Enable DRMs if required by the local network operator.
  - Verify that the CT Ratio matches the installed CT specification to ensure accurate power control and export limitation.
3. Confirm and Save:
  - Select OK to save the settings.
  - The inverter will automatically regulate its generation so that total PV DC power and AC output do not exceed the configured Max Solar Power limit.
  - When CT feedback is enabled, the inverter continuously monitors grid import/export and adjusts generation to maintain compliance with zero-export or limited-export conditions.



#### NOTICE

For installations requiring zero export operation, ensure the following:

- A correctly rated CT is installed at the main grid connection point.
- The CT ratio and polarity are correctly configured.
- The Max Solar Power limit is set according to the site's approved export capacity or adjusted to match on-site load consumption.

This inverter supports generation limit control through the Max Solar Power parameter under the **Advanced** → **Others** menu.

Proper configuration of this parameter and the CT ratio ensures compliance with AS/NZS 4777.2:2020, Clause 5.8 for generation control and export limiting.

# P-Shave

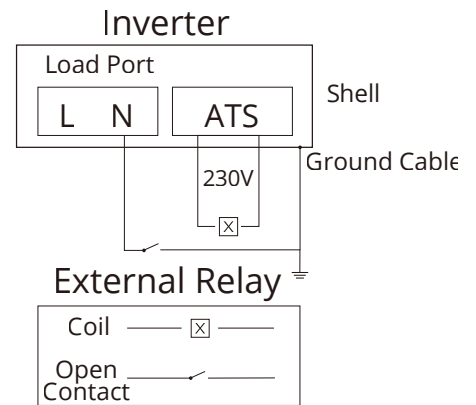
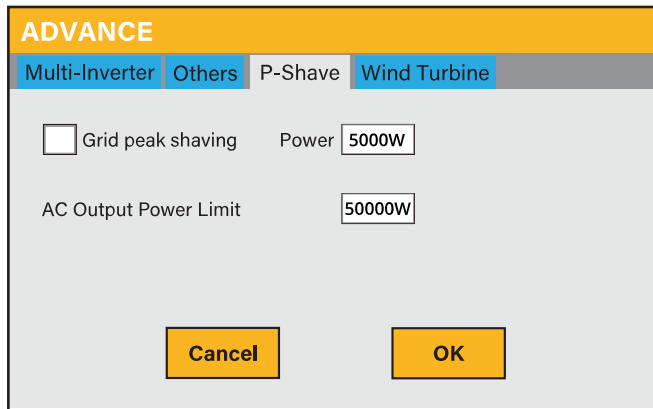

To configure the inverter for advanced functionality, navigate to the Advanced menu, then select the P-Shave tab.

## The following options will be available for configuration:

- **Grid Peak Shaving:** Grid Peak Shaving is a function that helps manage the load power supplied by the grid. When this option is selected, the inverter will limit the grid output power to a set value. Here's how it works:
  - If the load power exceeds the set limit, the inverter will use PV energy and stored battery energy to supplement the load.
  - If there is not enough PV energy or stored energy available to meet the load requirement, the inverter will increase grid power to fill the gap.

## What this setting does:

- Grid peak shaving ensures that your inverter does not exceed a preset limit for grid power, making it ideal for locations where grid power needs to be managed within a specific range.
- Benefits: This mode helps to reduce grid demand and minimises the risk of exceeding the grid's power supply limits.

## POWER SETTING

You can configure the maximum power setting (default is 5000W) to limit the amount of grid power that can be used. This setting ensures that the inverter will never pull more than the allocated grid power, helping to maintain grid stability and cost control.

## External Relay:

For more advanced configurations, such as integrating external devices like a relay to control additional operations, you can connect the External Relay port. Here's the required setup:

- **Relay coil:** Connect the relay coil as indicated in the diagram, which will control the inverter's power flow.
- **Open contact:** Connect the open contact to your external device to allow it to control or be triggered by the inverter's operation.

This connection allows the inverter to trigger external systems based on its operational status.

# Wind Turbine

**ADVANCE**  
**Multi-Inverter** Others Wind Turbine  
 DC1 for Wind Turbine  DC2 for Wind Turbine  
V1 90V 0.0A V7 210V 9.0A  
V2 110V 1.5A V8 230V 10.5A  
V3 130V 3.0A V9 250V 12.0A  
V4 150V 4.5A V10 270V 13.5A  
V5 170V 6.0A V11 290V 15.0A  
V6 190V 7.5A V12 310V 16.5A  
OK  
Cancel

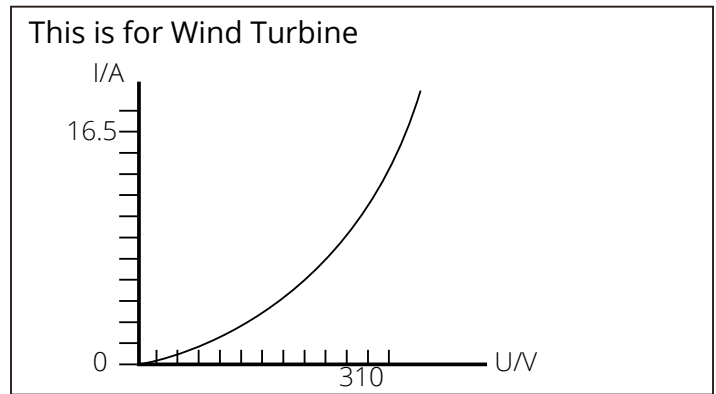

To configure the wind turbine settings, click on the ADVANCE icon in the menu.

## What this page displays:

- MPPT selection: If one or both of the MPPTs are connected to a wind turbine, this section will show the available configurations for wind turbine input settings.
- Wind turbine configuration: The screen shows the various options for wind turbine input, including the respective input voltages and currents for each MPPT.
- Wind turbine input settings: Allows you to configure the current and voltage ratings for wind turbine integration into the system.
- Graph for wind turbine: A graph depicting the relationship between the current (I) and voltage (U) for the wind turbine. This helps to visualise the wind turbine's performance curve and ensure proper configuration.

## What you can do from this page:

- Select the MPPT: Choose the MPPT (Maximum Power Point Tracking) to be used for the wind turbine input. If the inverter supports multiple MPPTs, you can configure which MPPT will handle the wind turbine's power input.
- DC input configuration: Configure the appropriate current ratings for the wind turbine to ensure efficient energy conversion.
- Wind turbine settings: Set the corresponding DC voltage and current limits (as shown in the options for V1, V2, etc.) for the wind turbine.



## NOTICE

Ensure the wind turbine's characteristics (voltage and current ratings) match the MPPT settings for proper energy harvesting and system performance.

# Solar Power Generated

This page displays the solar power produced on a daily, monthly, yearly, and total basis. To access this page, click on the Solar/Turbine icon on the Home Page.

## What this page displays:

- Return/Day/Month/Year/Total: This shows the total solar energy generated for the current day, month, year, and overall total.
- Solar Total Today: Displays the total amount of energy produced for the current day.
- Solar Total Month: Shows the cumulative solar power generated for the current month.
- Solar Total Year: Displays the total solar power generated in the current year.
- Solar/Turbine Power Total: This displays the total solar/turbine power generated over the entire operating period of the inverter, giving a complete overview of the system's total energy production from the beginning to the current date.

## The graphical display will include:

1. A daily power generation graph for the current day.
2. A monthly power generation graph for the current month.
3. A yearly power generation graph for the current year.
4. A total power generation display for the entire period.

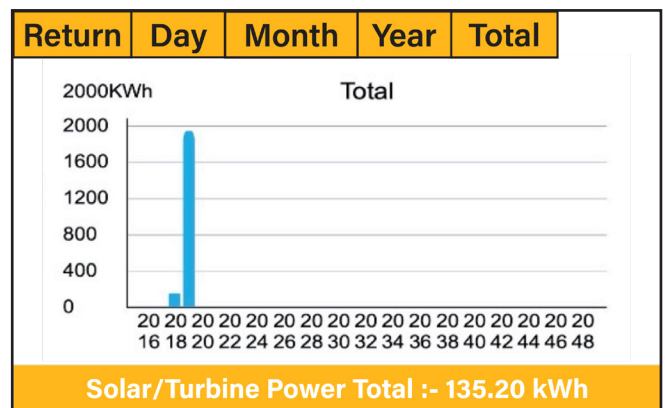
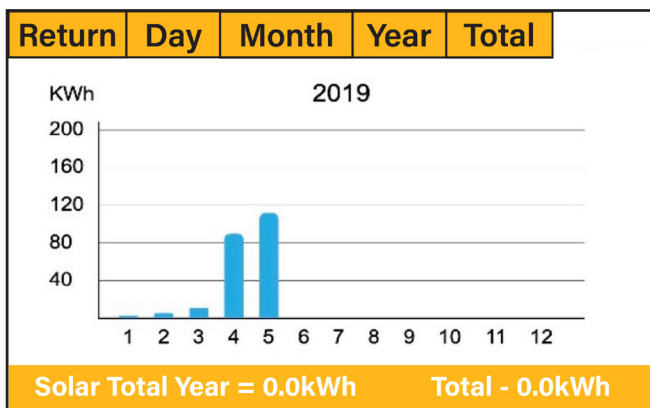
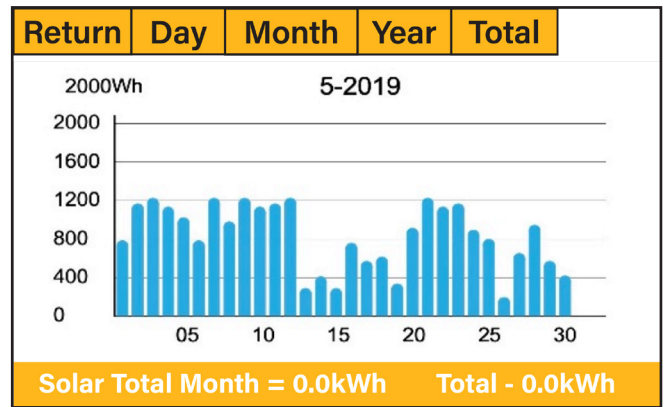
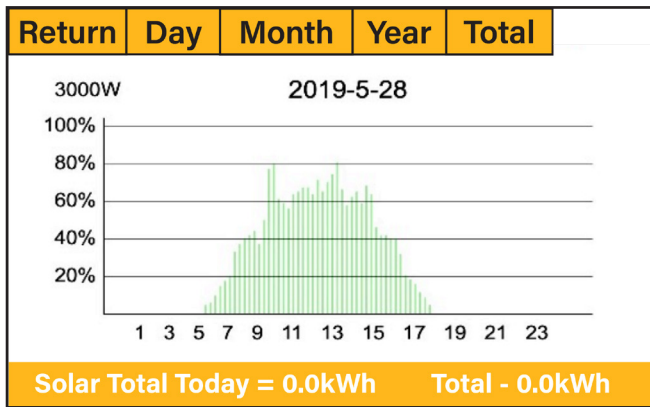

# Grid Power

This page displays the daily, monthly, yearly, and total grid power export or consumption. To access this page, click on the Solar/Turbine icon on the Home Page.

## What this page displays:

- Return/Day/Month/Year/Total: Shows the total grid power exported or consumed for the current day, month, year, and overall total.
- Grid Power Import/Export Day: Displays the total amount of power imported from or exported to the grid for the current day.
- Grid Power Import/Export Month: Shows the total amount of grid power imported or exported for the current month.
- Grid Power Import/Export Year: Displays the total amount of grid power imported or exported for the current year.
- Grid Power Import/Export Total: This displays the total amount of grid power consumed or exported over the entire operational period of the inverter, providing a comprehensive overview of grid-related energy exchanges.

## The graphical display will include:

1. A daily power consumption or export graph for the current day.
2. A monthly power consumption or export graph for the current month.
3. A yearly power consumption or export graph for the current year.
4. A total grid power export or consumption display for the entire period.

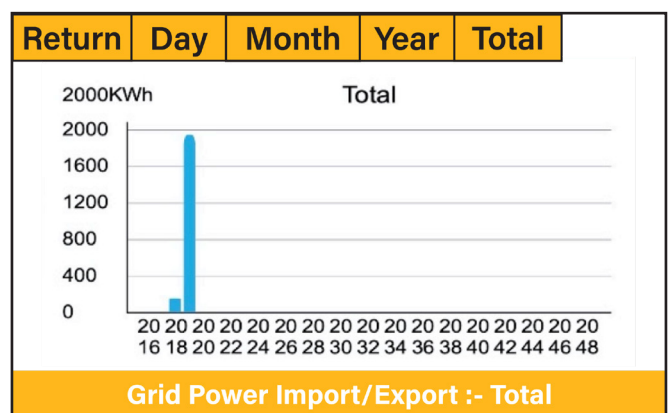
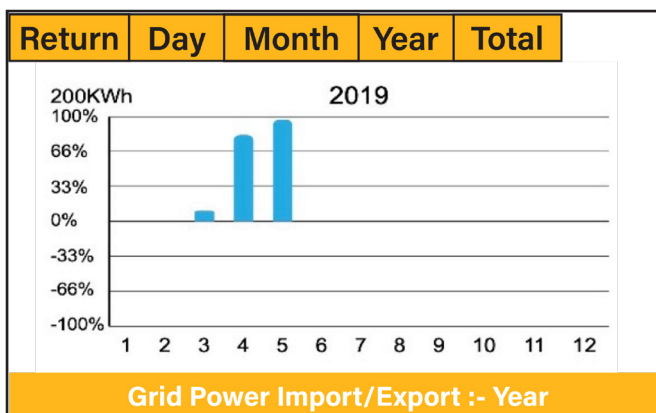
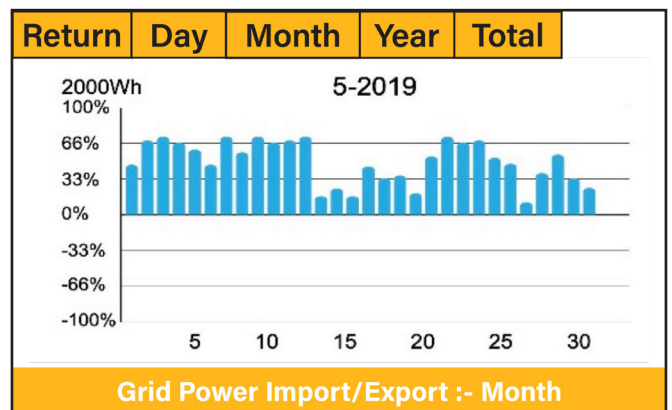
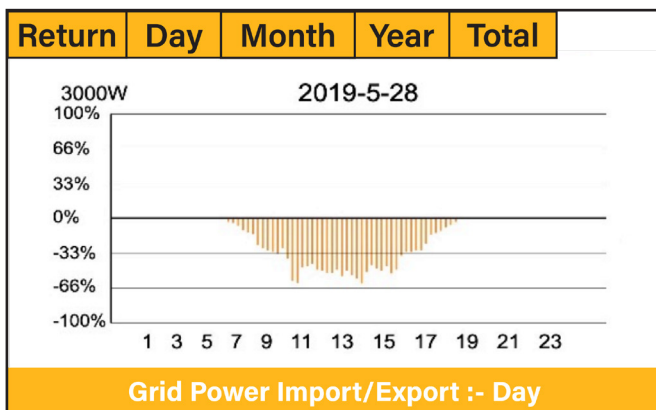

## Advanced Settings for Auxiliary Load

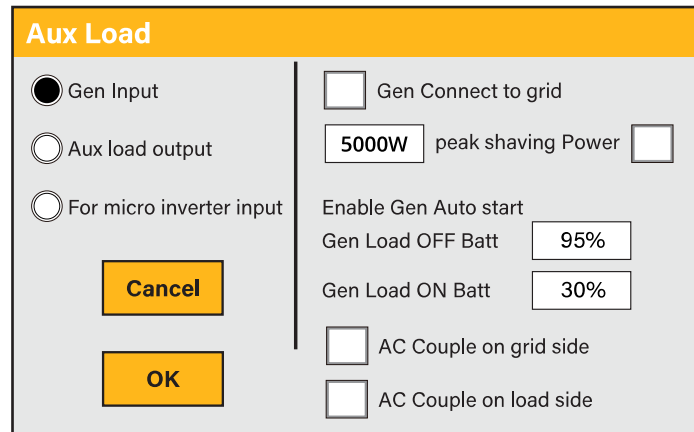

**Aux Load**

Gen Input

Aux load output

For micro inverter input

**Cancel**

**OK**

Gen Connect to grid

5000W peak shaving Power

Enable Gen Auto start

Gen Load OFF Batt 95%

Gen Load ON Batt 30%

AC Couple on grid side

AC Couple on load side

To configure Auxiliary Load (previously known as “smart load”) settings, click on the AUX LOAD icon in the menu.

### What this page displays:

- Use of the Gen (Aux) input or output: Allows you to select whether the generator peak shaving function is active.
- Gen peak shaving: This feature helps reduce electricity consumption during peak hours by managing the load between the inverter and the generator.
- Peak power shaving value: Defines the maximum power output from the generator to meet the demand while managing costs and avoiding excessive grid usage.

### What you can do from this page:

- Set up a generator input: Configure the input for the generator, enabling peak shaving power functionality.
- Set up an auxiliary load: Configure the settings to manage additional loads efficiently.
- Switch on generator and/or grid peak shaving: Enable peak shaving functionality for generator or grid connections, ensuring cost-effective operation during peak demand periods.
- Use additional inverters or micro inverters: Optionally, connect additional inverters or micro inverters for more flexible load management.

### FOR GEN INPUT MODE

- Gen Input: Tick this box if using a generator. You can set the maximum allowed power from the diesel generator.
- Gen Connect to grid: Connect the diesel generator to the grid input port.
- Peak Shaving Power: This function helps reduce electrical consumption during peak hours by diverting power from the grid or generator to manage demand efficiently.
- Gen Load OFF Batt: Defines the battery level at which the inverter switches to auxiliary load operation when the battery level is too low.
- Gen Load ON Batt: Configures the battery level at which auxiliary load will turn on. This ensures that the battery power is available when needed.
- AC Couple on load side: Connects the output of the on-grid inverter at the load port of the hybrid inverter. This ensures the hybrid inverter can handle the load appropriately.

### FOR AUX LOAD OUTPUT MODE

- **Aux Load Output:** This mode utilizes the Gen input connection as an output, which only receives power when the battery State of Charge (SOC) and PV power are above a user-programmable threshold.
  - For example: Power=500W, ON: 100%, OFF=95%. When the PV power exceeds 500W, and the battery bank SOC reaches 100%, the Smart Load Port will automatically switch on to power the connected load.
  - When the battery bank SOC < 95% or PV power < 500W, the Smart Load Port will switch off automatically.
- **Off Grid Immediately Off:** The smart load will stop working immediately when the grid is disconnected if this item is active.
- **On Grid Always On:** When this option is selected, the Smart Load will switch on when the grid is present.
- **Solar Power:** Power limiter to control the maximum power allowed to the Auxiliary load.
- **Aux Load OFF Batt:** Defines the battery SOC at which the Smart Load will switch off.
- **Aux Load ON Batt:** Defines the battery SOC at which the Smart Load will switch on. The PV input power should exceed the set value (Power) at the same time for the Smart Load to turn on.

### FOR MICRO INVERTER INPUT MODE

- **Micro Inverter Input:** This feature allows the Generator input port to be used as a micro-inverter on the grid inverter input (AC coupled). It works with "Grid-Tied" inverters. Tick this box if intending to connect a supplementary inverter or micro inverter (Max. 4kW).
- **AC Couple OFF Batt:** When the battery SOC exceeds the set value, the Microinverter or grid-tied inverter will shut down.
- **AC Couple ON Batt:** If "Micro Inv input" is selected, as the battery SOC reaches the set value (OFF), the output power from the microinverter will gradually decrease. When the battery SOC equals the set value (OFF), the system frequency will match the set value (AC couple Frz high), and the microinverter will stop working, halting the export of power to the grid.



### NOTICE

Micro Inv Input OFF and ON: This setting is valid for specific firmware versions only.

# OPERATING MODES

## Mode I: Basic

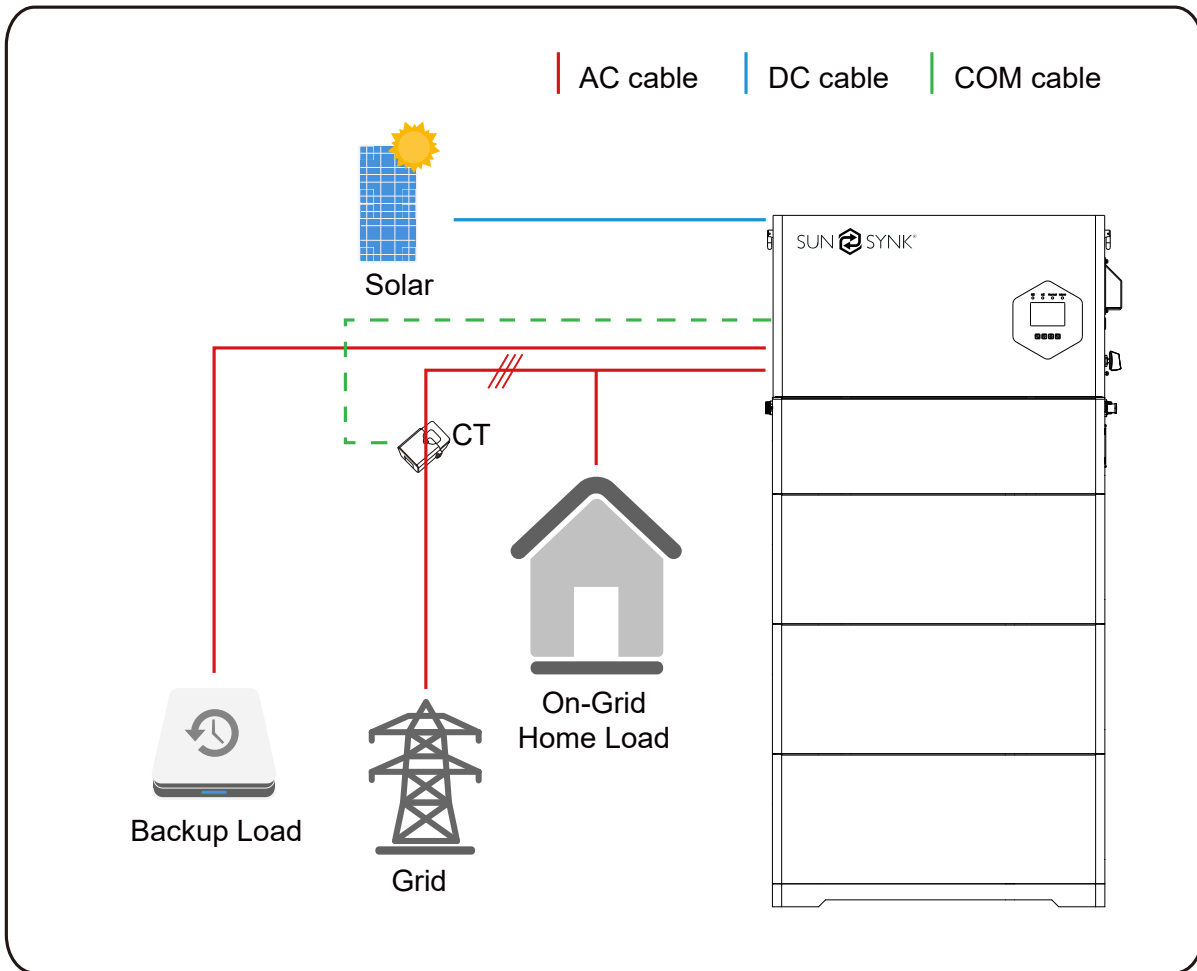

## Mode II: With Generator

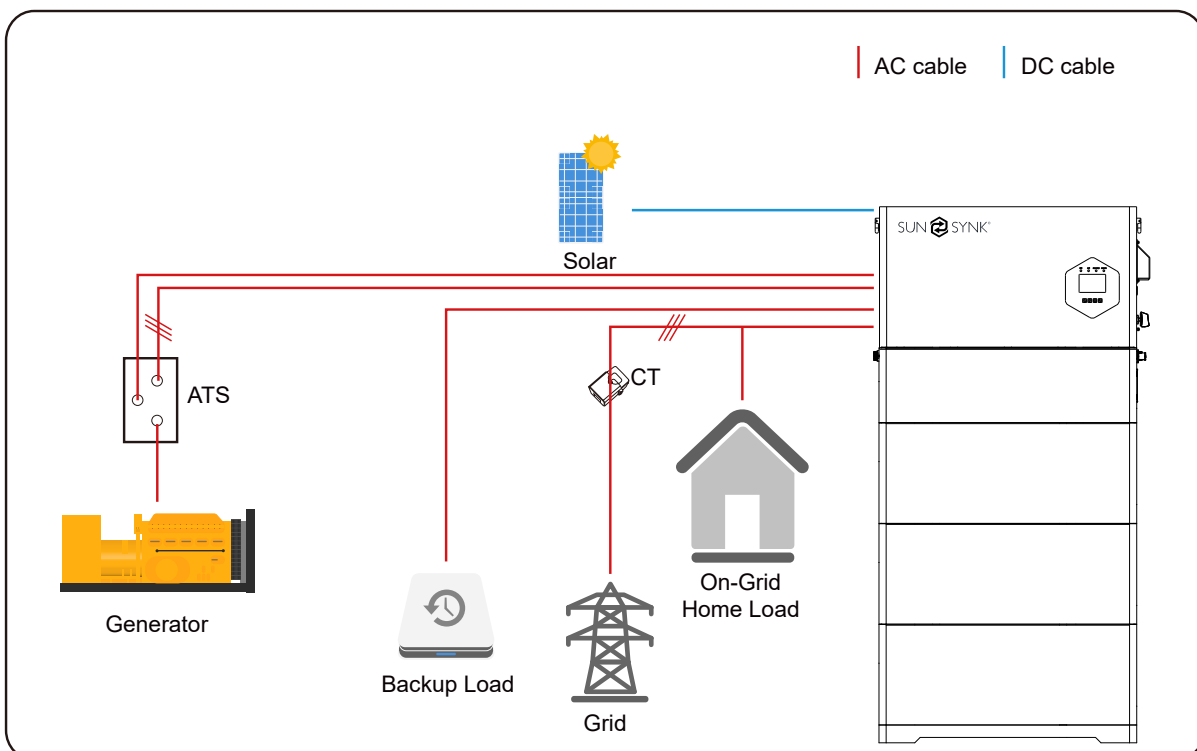

## Mode III: With Aux Load

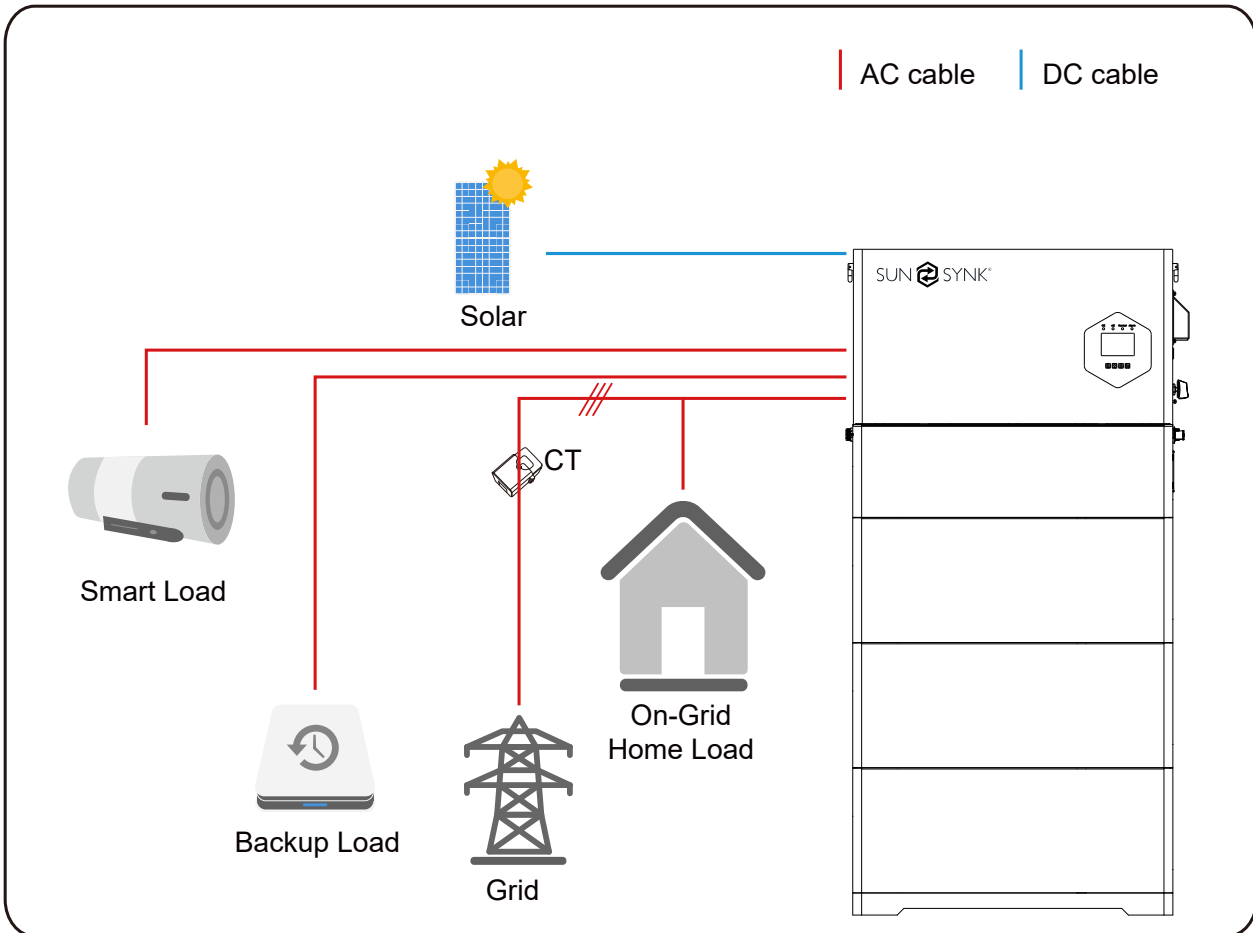

## Mode IV: AC Couple

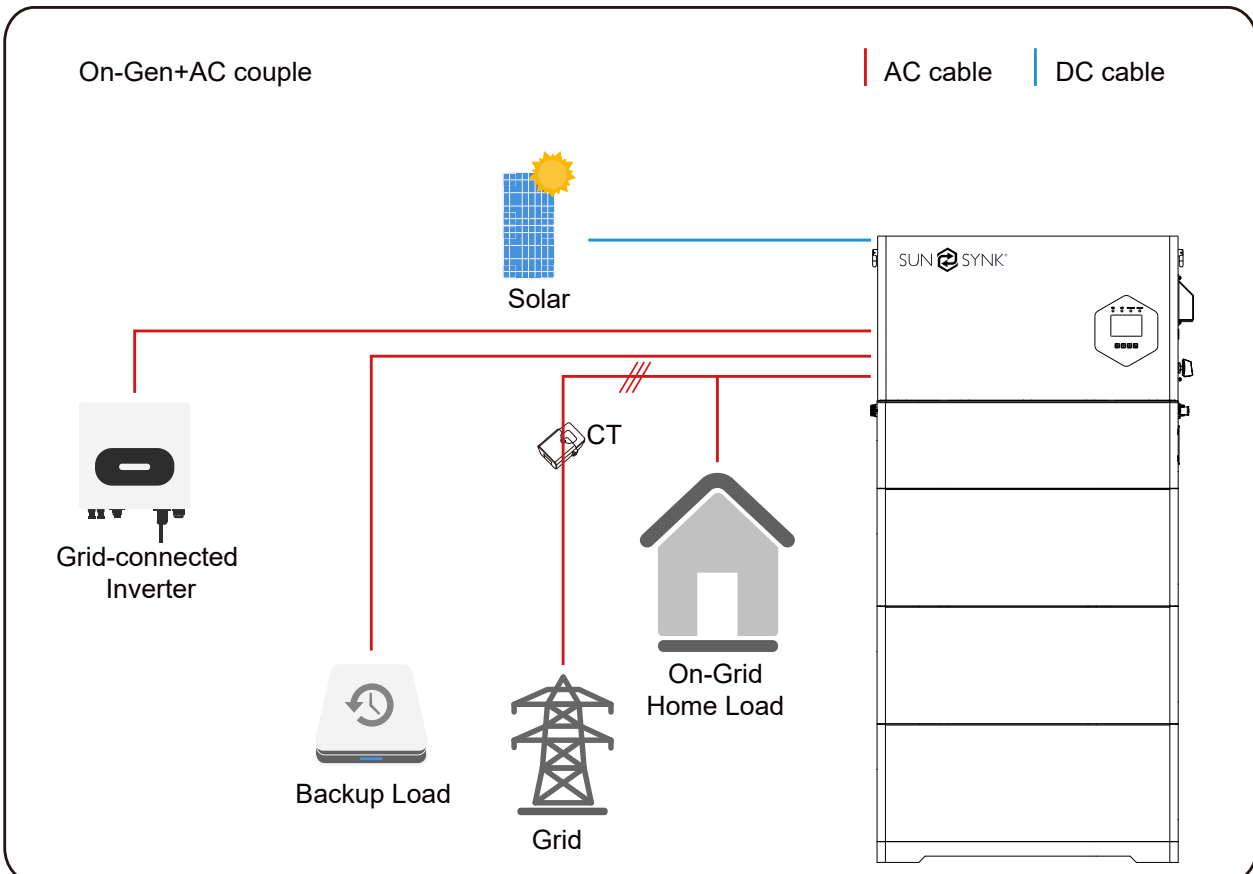

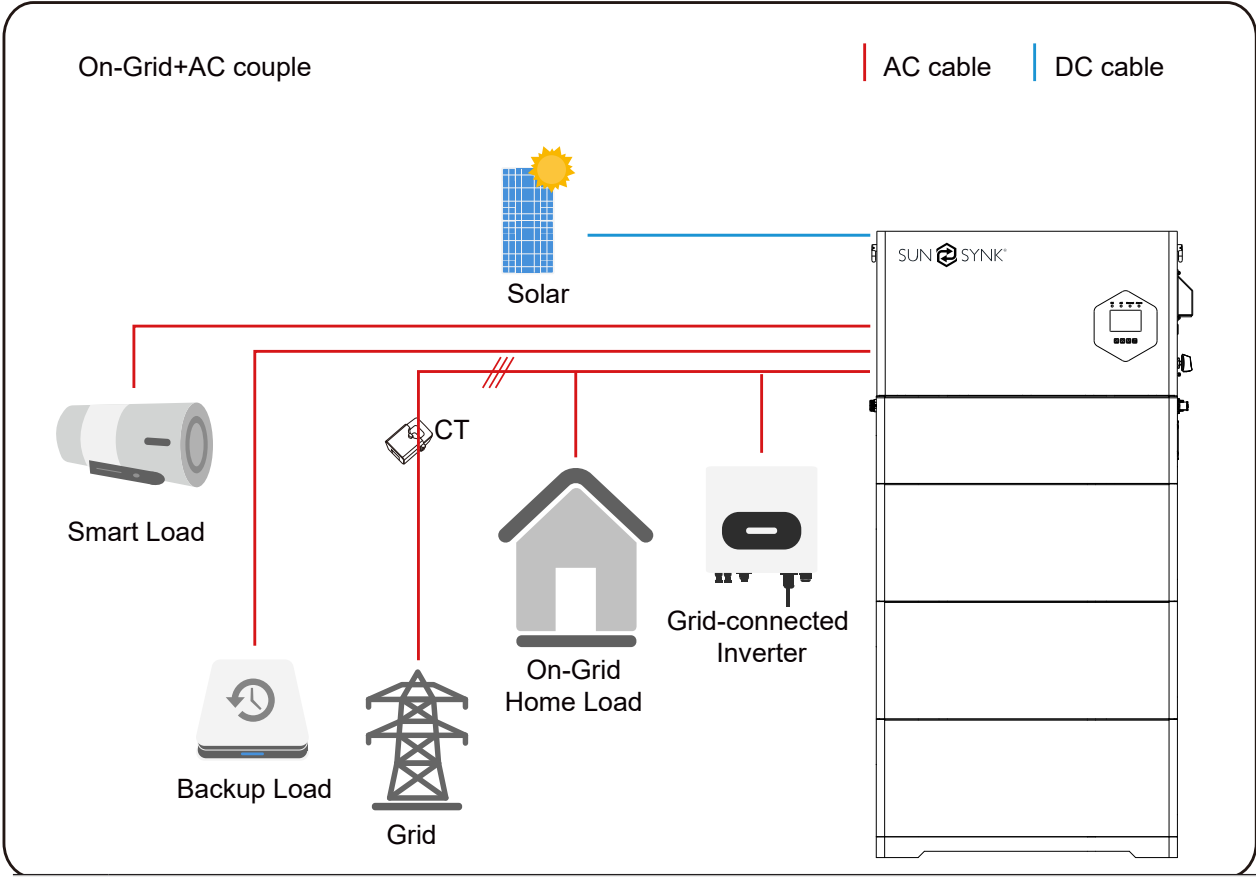
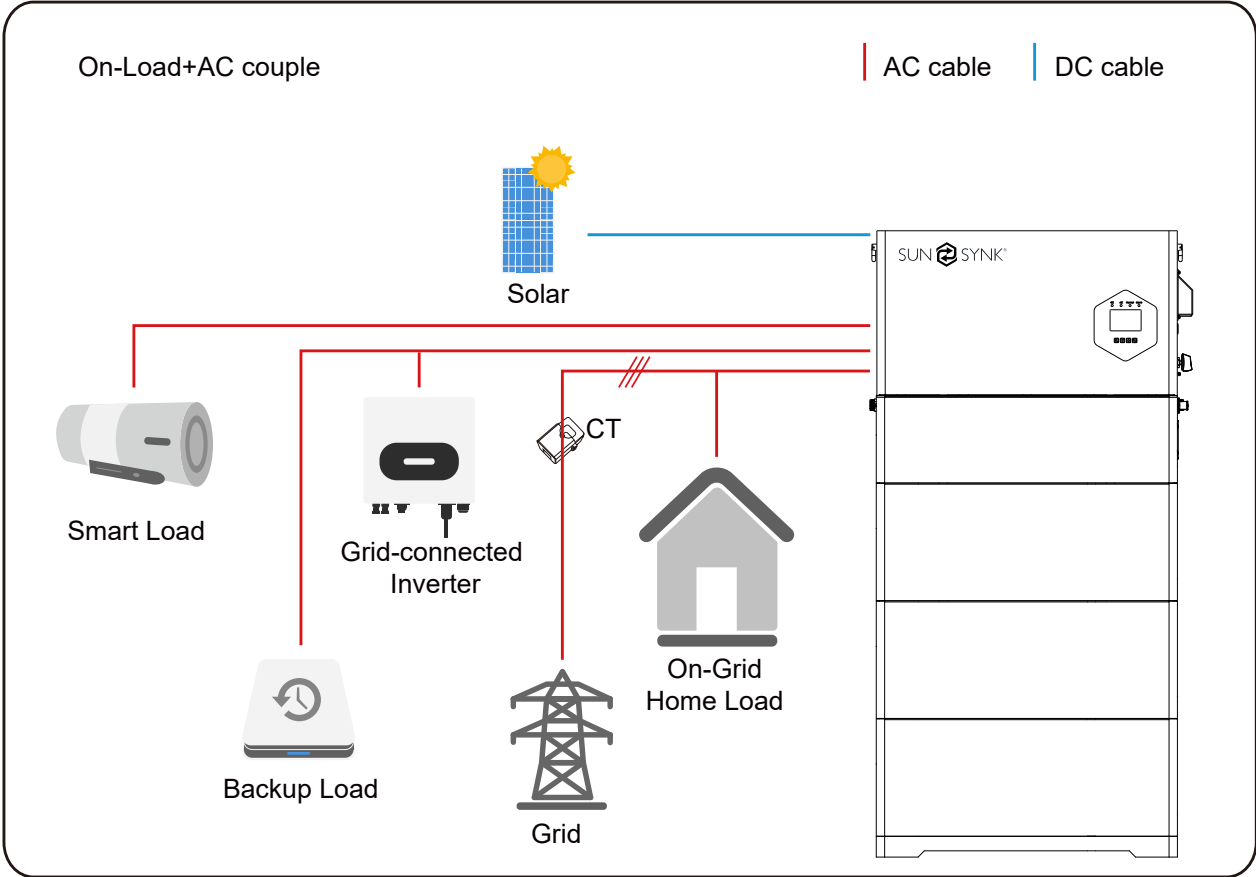

**WARNING**

The system's first priority power source is always solar (PV) power. The second and third priority power sources are the battery bank or grid power, depending on the configuration settings. Generator power will be used as a last resort if available.

# FAULT CODES

FAULT CODES		
Alarms Code	ID:2004244320	Occured
F56	DC_VoltLow_Fault	2022-01-26 12:45
F56	DC_VoltLow_Fault	2022-01-24 11:00
F56	DC_VoltLow_Fault	2022-01-07 18:19
F56	DC_VoltLow_Fault	2022-01-08 01:58
F56	DC_VoltLow_Fault	2021-11-09 13:22
F56	DC_VoltLow_Fault	2021-11-03 17:48
F56	DC_VoltLow_Fault	2021-10-27 16:31
F56	DC_VoltLow_Fault	2021-10-20 19:17

To check the fault codes, click on the FAULT CODES icon in the settings menu.

If any of the fault messages listed in the following table appear on your inverter and the fault has not been resolved after restarting, please contact your local vendor or service centre. The following information is required:

- Inverter serial number.
- Distributor or service centre of the inverter.
- On-grid power generation date.
- A detailed description of the problem (including the fault code and indicator status displayed on the LCD), as much information as possible.
- Owner's contact information.

In order to give you a clearer understanding of the inverter's fault information, we will list all possible fault codes and their descriptions when the inverter is not working properly.

Error Code	Description	Solutions
F08	GFDI_Relay_Failure	<ol style="list-style-type: none"> <li>1. When the inverter is in a Split phase (120/240Vac) or three-phase system (120/208Vac), the backup load port N line needs to connect ground;</li> <li>2. If the fault still exists, please get in touch with Sunsynk for help.</li> </ol>
F13	Working Mode Change	<p>Inverter work mode changed</p> <ol style="list-style-type: none"> <li>1. Reset the inverter.</li> <li>2. Seek help from Sunsynk.</li> </ol>
F18	AC over current fault or hardware	<p>AC Slide over current fault</p> <ol style="list-style-type: none"> <li>1. Check if the backup load power is within the range of the inverter.</li> <li>2. Restart, and check if it is normal.</li> </ol>
F20	DC over current fault of the hardware	<p>DC side over current fault</p> <ol style="list-style-type: none"> <li>1. Check PV module connect and battery connect;</li> <li>2. When in the off-grid mode, the inverter startup with a big power load, and it may report F20. Please reduce the load power connected.</li> <li>3. Turn off the DC and AC switches, wait one minute, and then turn on the DC/AC switch again.</li> <li>4. Seek help from Sunsynk if you can not return to a normal state.</li> </ol>

Error Code	Description	Solutions
F22	Tz_EmergStop_Fault	Please contact your installer for help.
F23	AC leakage current is trans over current	Leakage current fault 1. Check the PV module and inverter cables. 2. You may have a faulty PV panel (earth short) 3. Restart inverter
F24	DC insulation impedance failure	PV isolation resistance is too low 1. Check if the connection of PV panels and inverter are firmly connected. 2. Check if the earth bond cable on inverters is connected to the ground.
F26	The bus bar is unbalanced	1. Please wait 5 minutes to see if it returns to normal. 2. Fully reset the inverter.
F29	Parallel CANbus fault	1. When in parallel mode, check the parallel communication cable connection and hybrid communication address settings. 2. During the parallel system startup period, inverters will report F29. When all inverters are in ON status, it will disappear automatically. 3. If the fault exists, please contact Sunsynk for help.
F34	AC Overcurrent fault	1. Check the backup load connected, make sure it is in allowed power range. 2. If the fault still exists, please contact Sunsynk for help.
F35	No AC grid	No utility 1. Please confirm grid is lost or not. 2. Check the grid connection. 3. Check the switch between inverter and grid in on or not. 4. If the fault still exists, please contact Sunsynk for help.
F41	Parallel system stop	1. Check the hybrid inverter working status. If there's 1 pcs hybrid inverter is in OFF status, the other hybrid inverters may report F41 fault in parallel system. 2. If the fault exists, please contact Sunsynk for help.
F42	AC line low voltage	Grid voltage fault 1. Check if the voltage is in the range of standard voltage in specification this can be adjusted via the grid set up page. 2. Check if grid cables are correctly connected.
F47	AC_OverFreq_Fault	Grid frequency out of range 1. Check if the frequency is in the range of specification. 2. You may need to adjust the frequency on the grid set up page.
F48	AC_UnderFreq_Fault	Grid frequency out of range 1. Check the frequency is in the range of specification or not. 2. Check whether AC cables are firmly and correctly connected. 3. Seek help from us, if can not go back to normal state.

Error Code	Description	Solutions
F56	DC bus bar voltage is too low	<p>Battery low voltage</p> <ol style="list-style-type: none"> <li>1. Check if the battery voltage is too low.</li> <li>2. If the battery voltage is too low use the PV or grid to charge the battery.</li> <li>3. Check the battery BMS.</li> </ol> <p>Important: Especially with Lithium batteries, ensure that the batteries Max. discharge current or power specification is the same or higher than the inverter specification.</p>
F58	Battery_comm_Lose	<ol style="list-style-type: none"> <li>1. It tells the communication between hybrid inverter and battery BMS disconnected when "BMS_Err-Stop" is active.</li> <li>2. If you don't want to see this happen, you can disable "BMS_Err-Stop" item on the LCD.</li> <li>3. If the fault still exists, please contact Sunsynk for help.</li> </ol>
F63	ARC_Fault	<ol style="list-style-type: none"> <li>1. ARC fault detection is only for US market.</li> <li>2. Check PV module cable connection and clear the fault.</li> <li>3. Seek help from Sunsynk, if it can not go back to normal state.</li> </ol>
F64	Heat sink high-temperature failure	<p>Heat Sink temp is too high</p> <ol style="list-style-type: none"> <li>1. Check if the working environment temperature is too high.</li> <li>2. Turn off the inverter for 30 minutes and restart.</li> </ol>

Fault Information	Instruction	Fault Information	Instruction
F01	DC_Inversed_Failure	F33	AC_OverCurr_Fault
F02	DC_Insulation_Failure	F34	AC_Overload_Fault
F03	GFDI_Failure	F35	AC_NoUtility_Fault
F04	GFDI_Ground_Failure	F36	AC_GridPhaseSeque_Fault
F05	EEPROM_Read_Failure	F37	AC_Volt_Unbalance_Fault
F06	EEPROM_Write_Failure	F38	AC_Curr_Unbalance_Fault
F07	GFDI_Fuse_Failure	F39	INT_AC_OverCurr_Fault
F08	GFDI_Relay_Failure	F40	INT_DC_OverCurr_Fault
F09	IGBT_Failure	F41	AC_WU_OverVolt_Fault
F10	AuxPowerBoard_Failure	F42	AC_WU_UnderVolt_Fault
F11	AC_MainContactor_Failure	F43	AC_VW_OverVolt_Fault
F12	AC_SlaveContactor_Failure	F44	AC_VW_UnderVolt_Fault
F13	Working_Mode_change	F45	AC_UV_OverVolt_Fault
F14	DC_OverCurr_Failure	F46	AC_UV_UnderVolt_Fault
F15	AC_OverCurr_Failure	F47	AC_OverFreq_Fault
F16	GFCI_Failure	F48	AC_UnderFreq_Fault
F17	Tz_COM_OC_Fault	F49	AC_U_GridCurr_DcHigh_Fault
F18	Tz_Ac_OverCurr_Fault	F50	AC_V_GridCurr_DcHigh_Fault
F19	Tz_Integ_Fault	F51	AC_W_GridCurr_DcHigh_Fault
F20	Tz_Dc_OverCurr_Fault	F52	AC_A_InductCurr_DcHigh_Fault
F21	Tz_GFDI_OC_Fault	F53	AC_B_InductCurr_DcHigh_Fault
F22	Tz_EmergStop_Fault	F54	AC_C_InductCurr_DcHigh_Fault
F23	Tz_GFCI_OC_Fault	F55	DC_VoltHigh_Fault
F24	DC_Insulation_Fault	F56	DC_VoltLow_Fault
F25	DC_Feedback_Fault	F57	AC_BackFeed_Fault
F26	BusUnbalance_Fault	F58	AC_U_GridCurr_High_Fault
F27	DC_Insulation_ISO_Fault	F59	AC_V_GridCurr_High_Fault
F28	DCIOver_M1_Fault	F60	AC_W_GridCurr_High_Fault
F29	AC_AirSwitch_Fault	F61	AC_A_InductCurr_High_Fault
F30	AC_MainContactor_Fault	F62	AC_B_InductCurr_High_Fault
F31	AC_SlaveContactor_Fault	F63	ARC_Fault
F32	DCIOver_M2_Fault	F64	Heatsink_HighTemp_Fault



## NOTICE

The Single-Phase Hybrid Inverter is designed for grid-connected operation. The inverters meet the main standards concerning safety and electromagnetic compatibility. Before leaving the factory, all inverters undergo rigorous testing to ensure the inverter can operate reliably, as presented in the Technical Specifications chapter.

# INVERTER MONITORING

Sunsynk inverter monitoring is easily accessible via the Sunsynk Connect and Sunsynk Connect Pro Cloud apps. To enable monitoring of inverter functionality and performance, a data logger must be properly connected to the inverter and to WIFI, and a site plant must be created via the Sunsynk Connect or Sunsynk Pro Cloud apps. For detailed instructions on the Sunsynk Connect or Sunsynk Connect Pro Cloud App and setting up system monitoring, refer to the Sunsynk Connect or Sunsynk Connect Pro User Manual on sunsynk.org

The following illustrations show how to register, create a plant for a site and monitor a inverter online with ease.

## Data Logger Installation

**1** Insert the Data Logger into the DB9 interface of the inverter, as shown in the following figure.

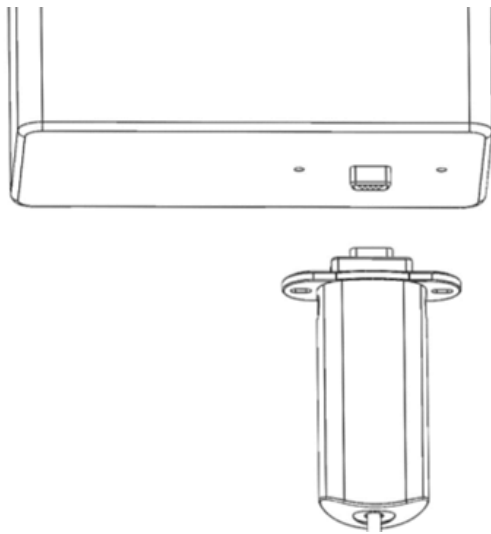

**2** Insert the two screws that come with the Data Logger through the holes, and then tighten them with a Phillips screwdriver, as shown in the figure below.

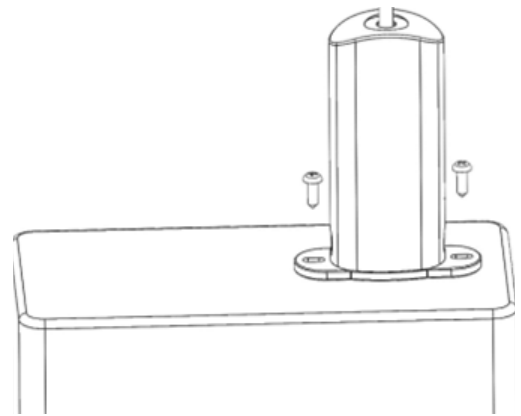

## Connecting to Wi-Fi

To connect the data logger to the Wi-Fi you need to go to the Wi-Fi setting on your device and search for it. You will see an available connection with the SSID 'EAP-\*\*\*\*\*' ('\*\*\*\*\*' are the last 5 digits of the serial number on the data logger).

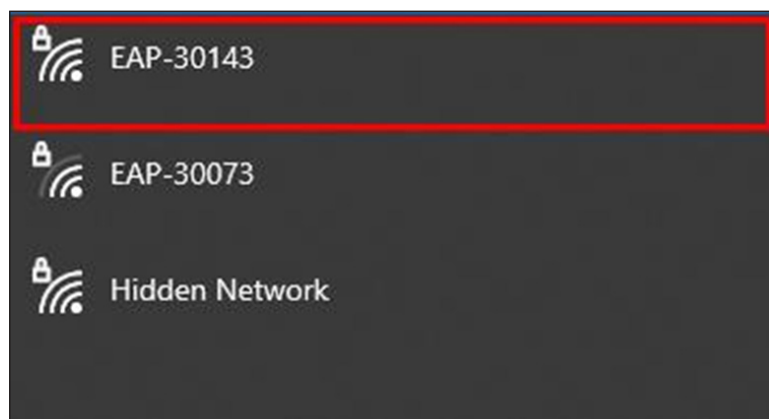

- 1 Select the correct connection and then enter the password 12345678.

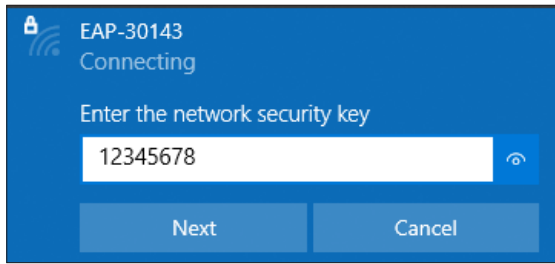

- 2 Once you have connected to the EAP connection, you need to connect it to your own Wi-Fi. To do this, open the Internet browser and search the IP address 10.10.10.1.

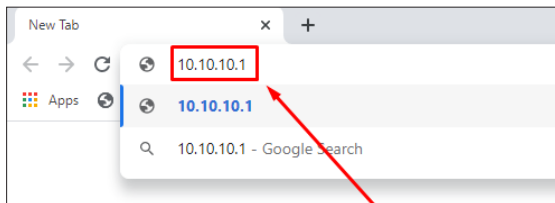

- 3 Once connected, click 'Scan' to search the Wi-Fi List and you should then see your Wi-Fi connection.

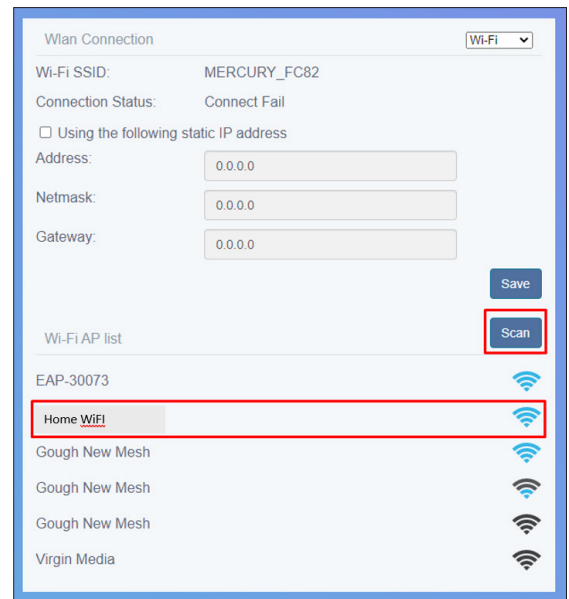

- 4 Select your Internet / Wi-Fi connection, enter your password, and click 'Connect'.

- 5 Once your data logger is connected to your Wi-Fi, you can then disconnect from the data loggers EAP connection and connect back to your usual Wi-Fi connection.

## Network Cable

- 1 Use a flat-blade screwdriver to press the buckles on the left and right sides of the shell, as shown in the following figure. Then extract the DB9 interface part manually.

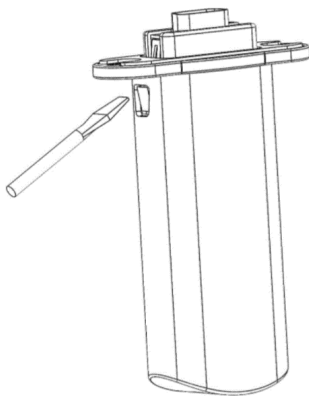

- 2 Pass the network cable through its specific hole at the bottom of the shell. Then, insert the RJ45 plug into the RJ45 socket, and place the sealing plug with the hole on the network cable, as shown in the figure below.

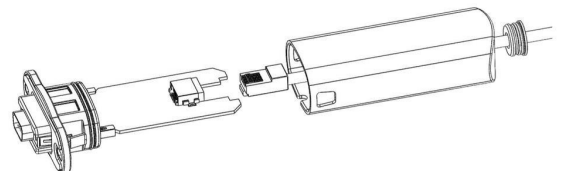

# Registration

**1** Visit <https://sunsynk.net> in your browser to access the web version of the management tool. Click on 'Sign Up' on the Login page to proceed to the Registration page.

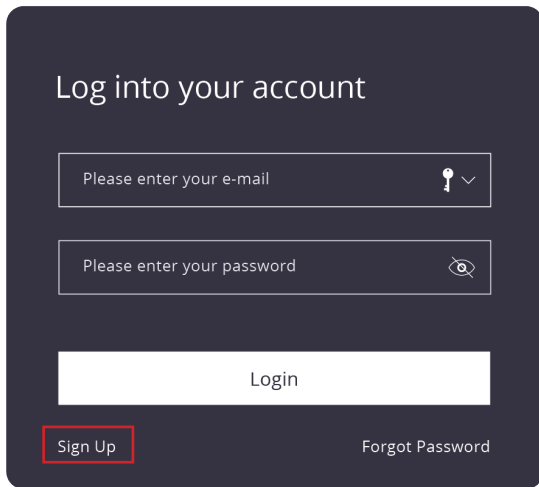

The screenshot shows a dark-themed login page titled "Log into your account". It features two input fields: "Please enter your e-mail" with a key icon and "Please enter your password" with an eye icon. Below these is a "Login" button. At the bottom left, the "Sign Up" button is highlighted with a red box. At the bottom right, there is a "Forgot Password" link.

**2** Enter a valid email address to receive a verification code. Complete the registration form by setting a password, checking the user agreement box to confirm agreement, and then click 'Agree and Register'.

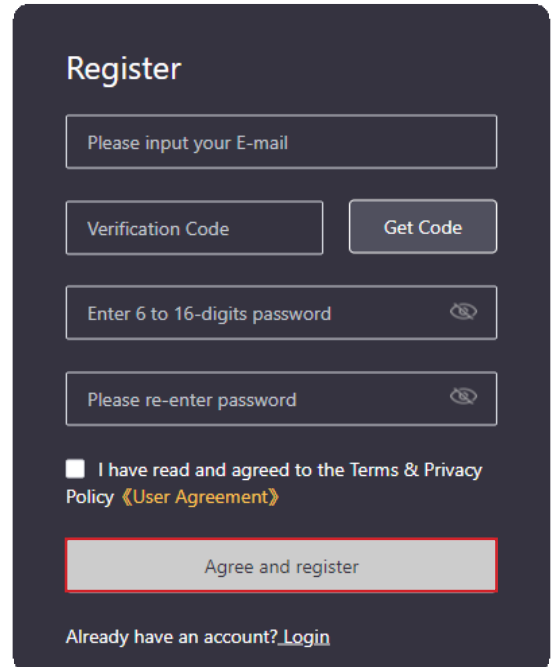

The screenshot shows a dark-themed registration page titled "Register". It includes an "E-mail" input field, a "Verification Code" input field, and a "Get Code" button. Below these is a password input field with the instruction "Enter 6 to 16-digits password" and an eye icon. A second password input field is labeled "Please re-enter password" with an eye icon. A checkbox is checked, with the text "I have read and agreed to the Terms & Privacy Policy" and a link to "User Agreement". The "Agree and register" button is highlighted with a red box. At the bottom, there is a link: "Already have an account? Login".

## Requesting User Level Access Change

If you are an installer who has registered on the Sunsynk Connect platform, you may initially have a basic user account with limited permissions. To request elevated user access for parameter changes, remote inverter upgrades, and other functions, please visit <https://www.sunsynk.org/remote-monitoring> and complete the form provided.

# Creating a Plant

**1** Navigate to the menu and click on 'My Plant', then select 'Plant List'.

**2** To initiate a new plant setup, click on 'Create a Plant' located in the right of the page.

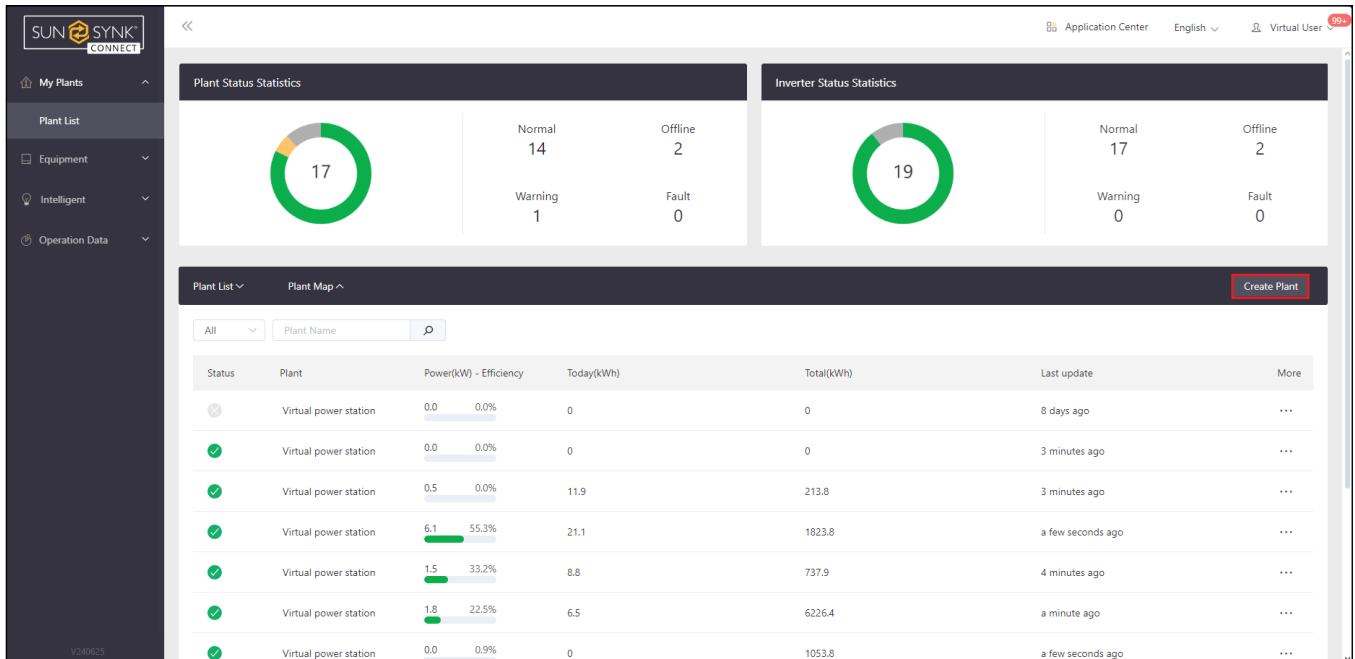

**3** Enter the Serial Number (SN) and KEY from the Data Logger label, then click 'Next'.

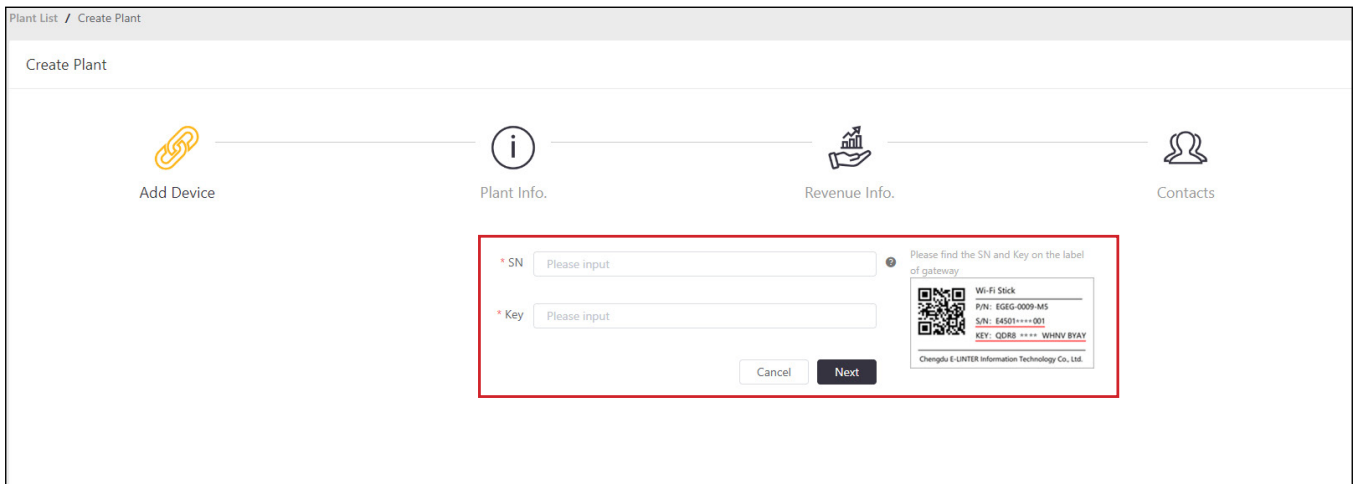

**4** Specify the total capacity in the 'Capacity' field and choose the appropriate 'Plant Type'. Note that different types of plants will display different information on the page. To ensure accurate plant statistics, complete all required fields accurately.

**5** Enter the installation address of the plant in the address input box on the map to pinpoint the exact location, or use the map to select the correct installation site.

**6** Verify and adjust the plant's time zone if necessary. Click 'Next' to proceed.

Plant List / Create Plant

Create Plant

Add Device    Plant Info.    Revenue Info.    Contacts

**4**

\* Plant Name

\* Capacity  MW

\* Commissioning Date

Installer

Upload picture. The file format must be JPG, PNG, PNG, and size can not exceed 10MB

**5**

Please input Address

**6**

Longitude and latitude : -2.715899,53.370591

Address : 60 Frank St, Widnes WAB, Cheshire, UK

\* Time Zone (UTC+04:00)Azerbaijan Ulyanovsk  Check whether the selected time zone is correct

Back Next

**7** Select your currency, specify the total investment, and choose your preferred Valuation Method.  
**Note:** The Live Price option is currently available only for UK customers.

Plant List / Create Plant

Create Plant

Add Device    Plant Info.    Revenue Info.    Contacts

\* Currency

Total Investment  \$

\* Valuation Method  Constant Price  Time of use price  Live Price

\$/kWh

Back Next

**8** Provide the name, phone number, and email address of the user responsible for managing the system.

Plant List / Create Plant

Create Plant

Add Device    Plant Info.    Revenue Info.    Contacts

\* Manager

\* Phone

E-mail

Back Complete

## Adding a Device

- 1 In the menu, first click 'My Plant', then 'Plant List'.
- 2 Select the plant that need to add equipment from the 'Plant List'.
- 3 Click the 'More (...)' button and Select 'Add Gateway'.

The screenshot shows the SUN SYNK CONNECT dashboard. On the left is a navigation menu with 'My Plants' selected, and 'Plant List' is highlighted. The main area displays 'Plant Status Statistics' and 'Inverter Status Statistics' at the top. Below is a 'Plant List' table with columns: Status, Plant, Power(kW) - Efficiency, Today(kWh), Total(kWh), Last update, and More. The first row is highlighted in red. A 'More' menu is open for this row, with 'Add Gateway' selected. Other menu items are 'Edit' and 'Disassociate'.

Status	Plant	Power(kW) - Efficiency	Today(kWh)	Total(kWh)	Last update	More
⊗	Virtual power station	0.0 0.0%	0	0	4 days ago	⋮
✔	Virtual power station	0.0 0.0%	0	0	a minute ago	⋮
✔	Virtual power station	0.3 0.0%	4.8	170.1	a few seconds ago	⋮
✔	Virtual power station	1.2 10.6%	20.8	1719.4	2 minutes ago	⋮

- 4 Input the serial number SN and key of the Data Logger to be connected, then click 'Confirm'.

The screenshot shows the same dashboard as above, but with a modal dialog box titled 'Add Gateway' in the center. The dialog has two input fields: '\* SN' and '\* Key', both with 'Please input' as placeholder text. At the bottom of the dialog are 'Cancel' and 'Confirm' buttons.

## Editing a Plant

- 1 In the menu, first click 'My Plant', then 'Plant List'.
- 2 Select the plant that need to be edited from the 'Plant List'.
- 3 Click the 'More (...)' button and select 'Edit'.

The screenshot shows the same dashboard as above, but with the 'More' menu for the first row open, and 'Edit' selected instead of 'Add Gateway'.

# 4 Review and make edits to any previously entered information as needed.

## Plant Overview

1 In the menu, first click 'My Plant', then 'Plant List'.

2 Select plant list 'Plant List' and click the corresponding plant name to enter the plant Overview page.

Status	Plant	Power(kW) - Efficiency	Today(kWh)	Total(kWh)	Last update	More
✓	Virtual power station	0.5 9.5%	3.4	4265.9	5 minutes ago	...
✓	Virtual power station	4.5 37.7%	22.9	13551.1	4 minutes ago	...
✓	Virtual power station	0.4 5.6%	9.8	5679.4	a minute ago	...

**3** On the Plant Overview page, you can monitor the plant's status, weather conditions, energy flow diagram, inverter status, recent abnormalities, power generation charts, and other relevant information (as illustrated on the next page).

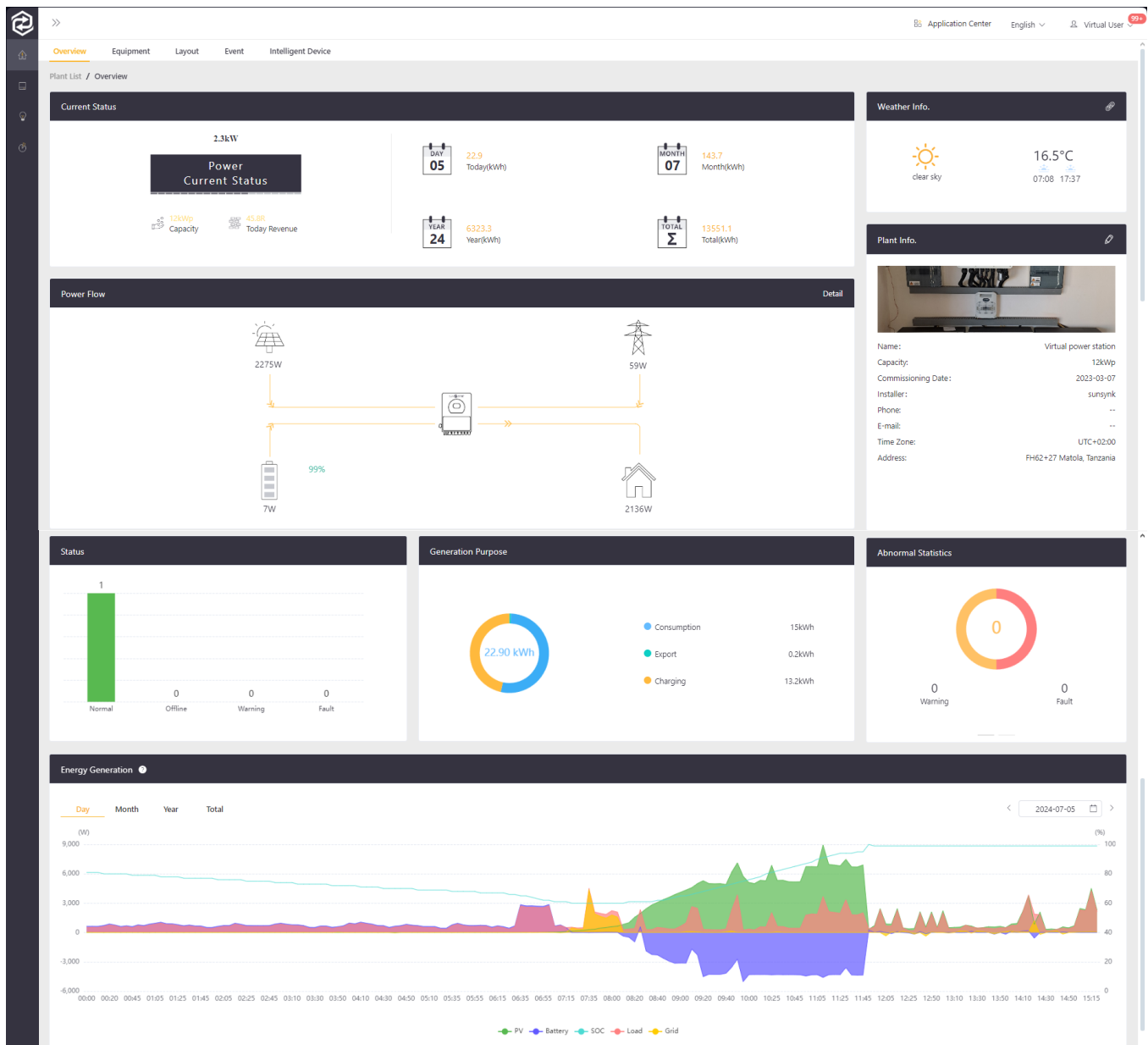

**4** Click on 'Equipment' within the Overview page to access detailed information about all equipment installed in the plant. Here, you can view operational data charts, perform remote upgrades, adjust parameter settings, and manage other operations.

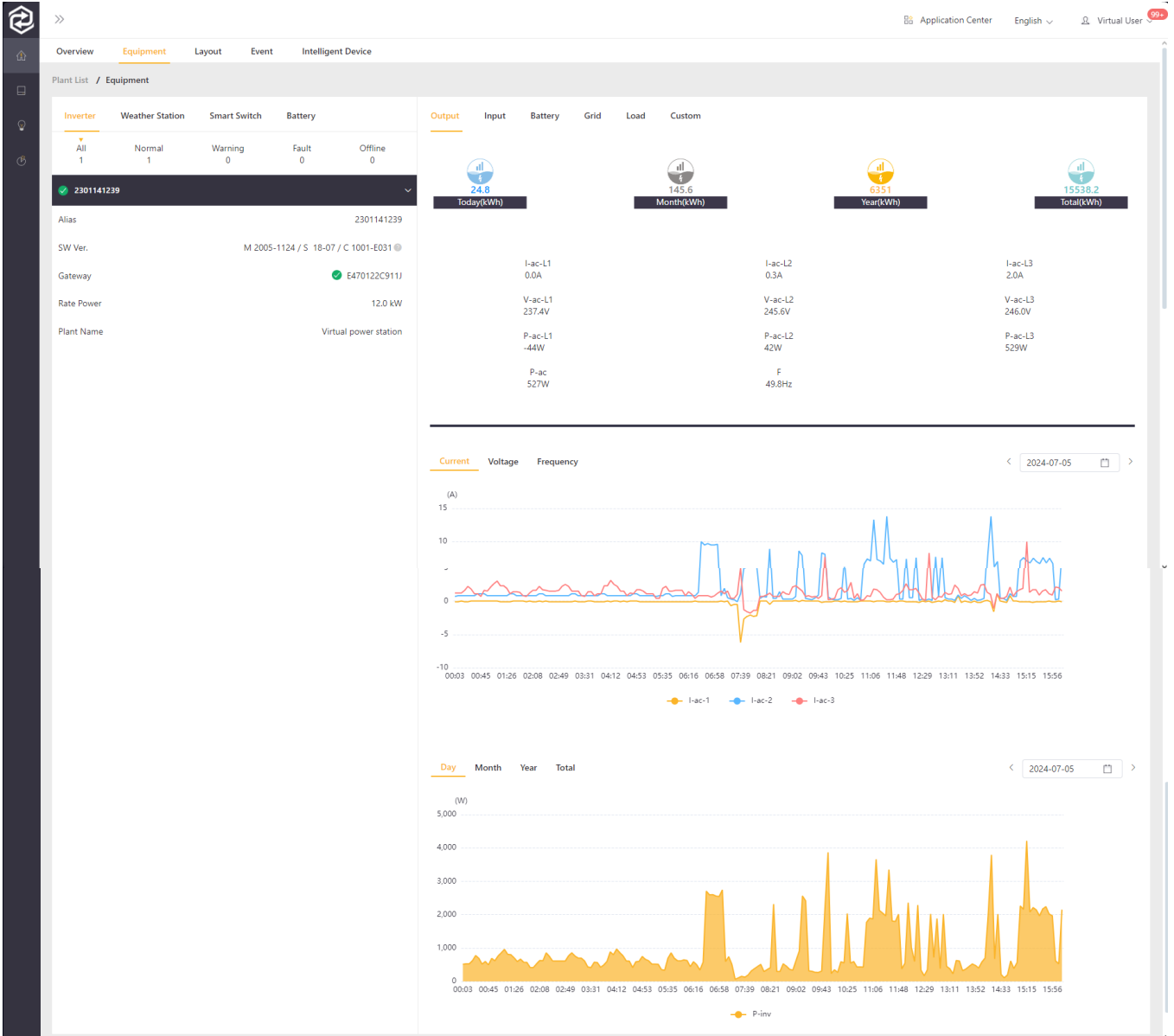

5 On the Plant Layout page, you can monitor the plant's layout.

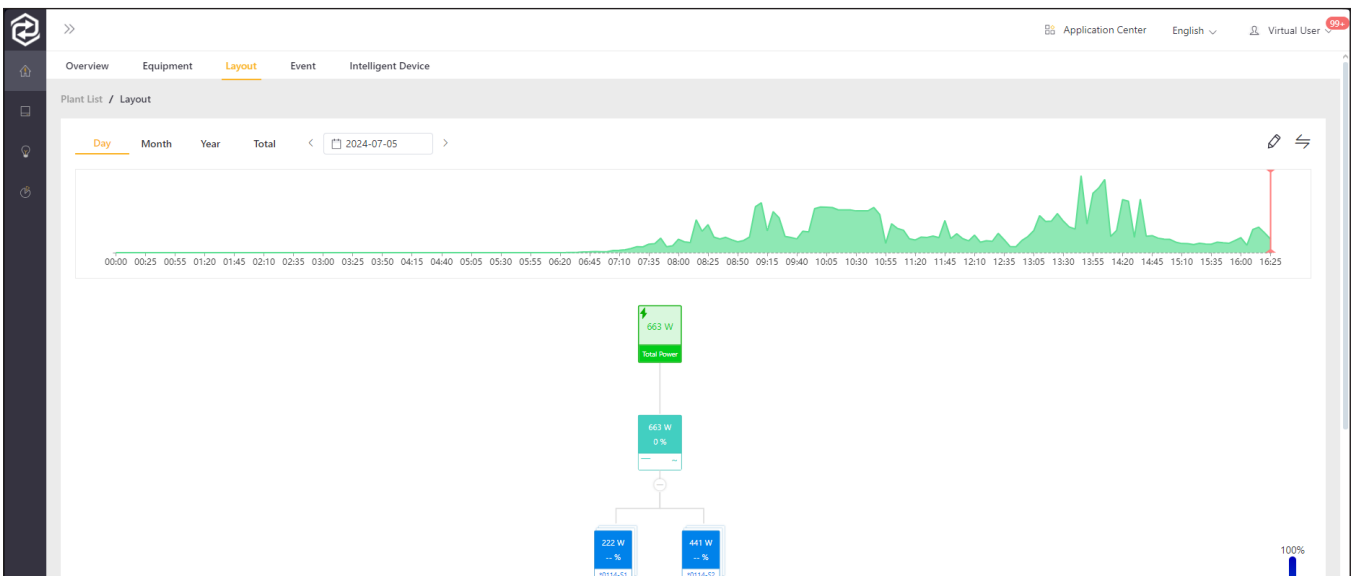

**6** Navigate to the 'Event' menu on the Plant Overview page to switch to the Event page. Here you can view the current plants abnormal information.

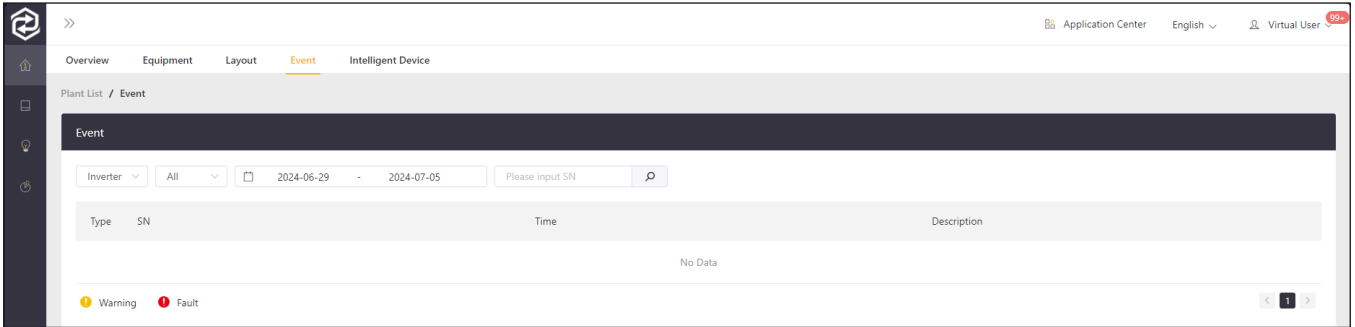

**7** On the Plant Intelligent device...

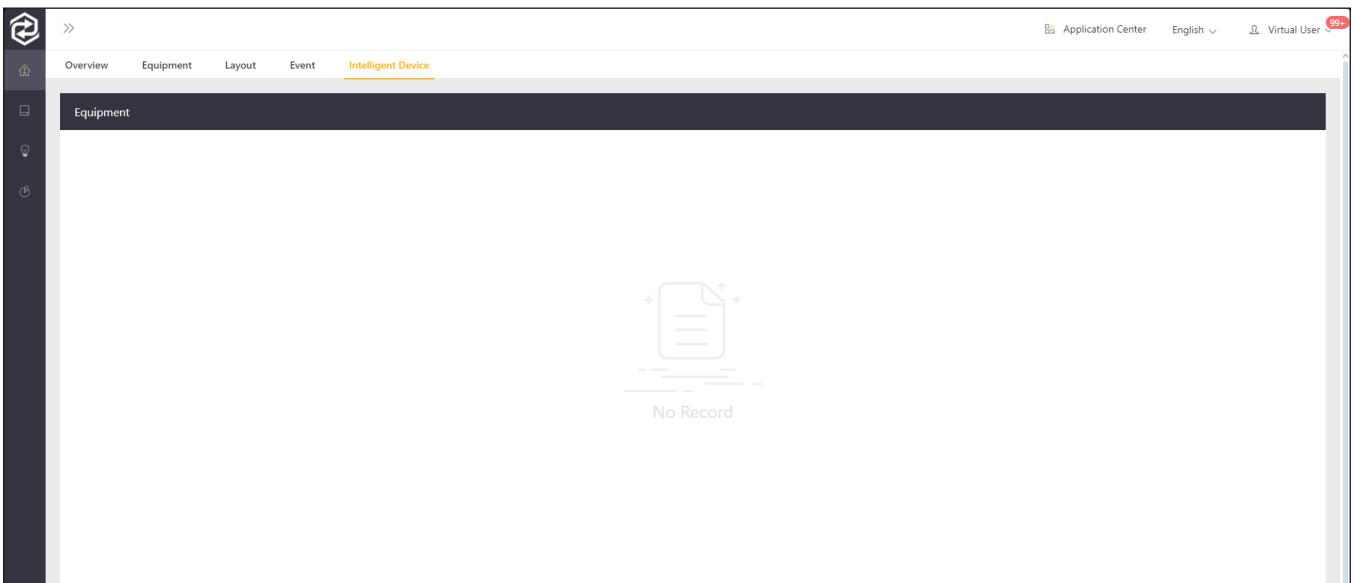

## Inverter Management

**1** In the menu, click 'Equipment', then 'Inverter' to enter the Inverter List page.

**2** In the Inverter List page, click on the SN of an inverter to view the detailed information and operational data of the inverter.

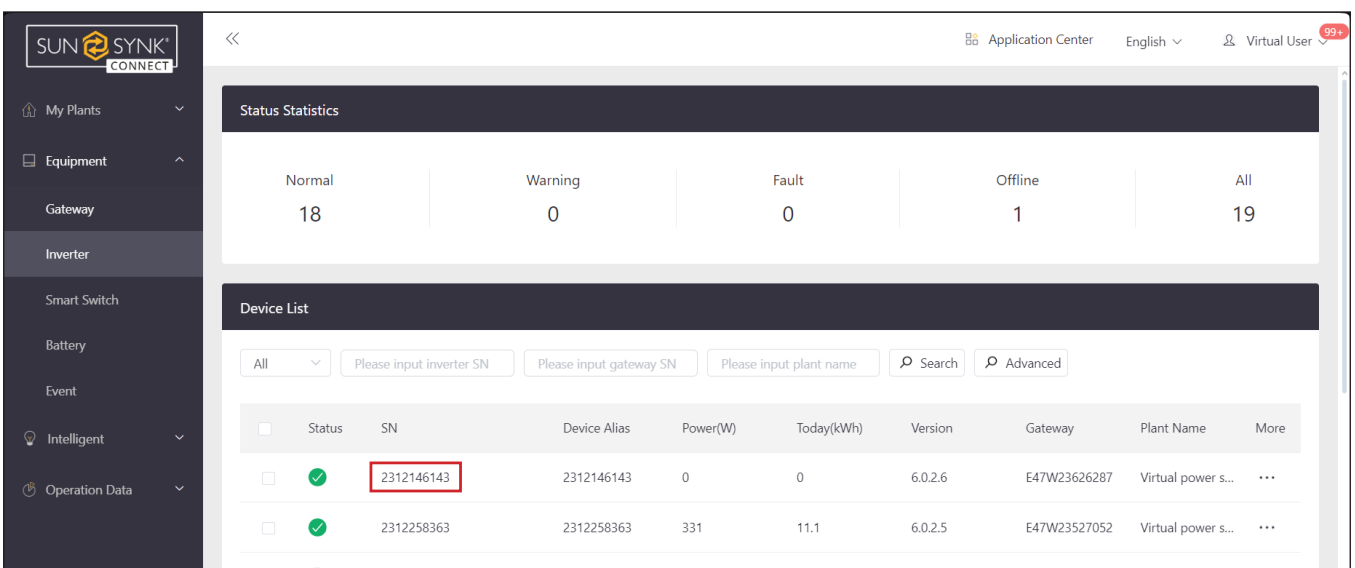

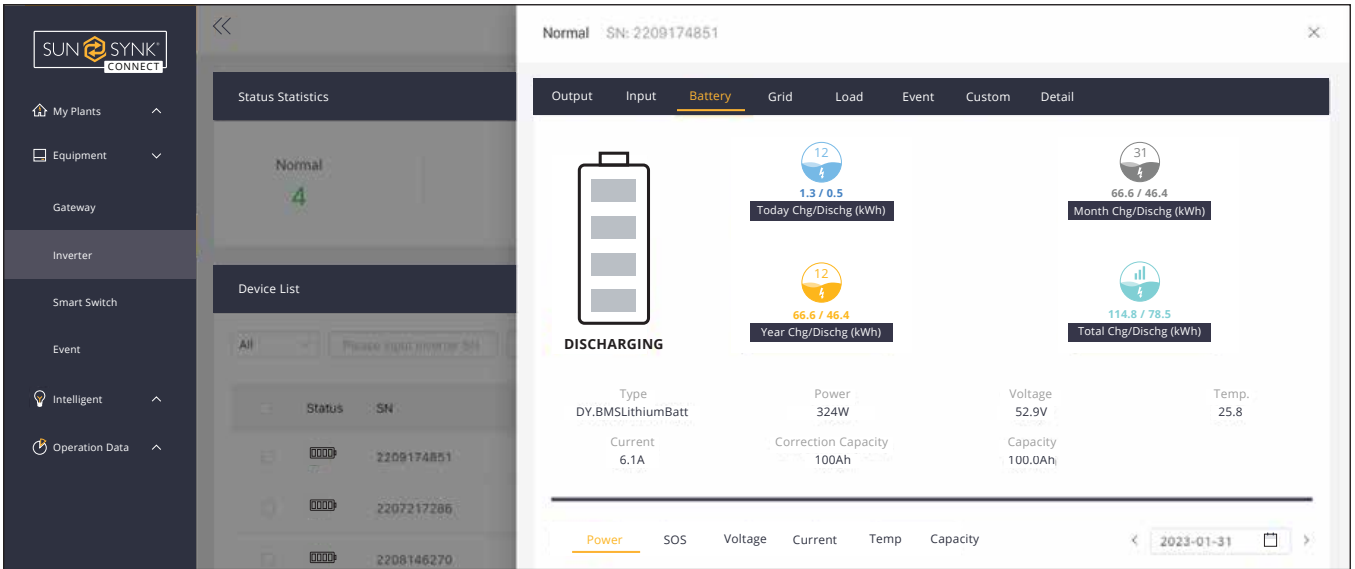

**3** Click on the plant name to enter the plant of the inverter.

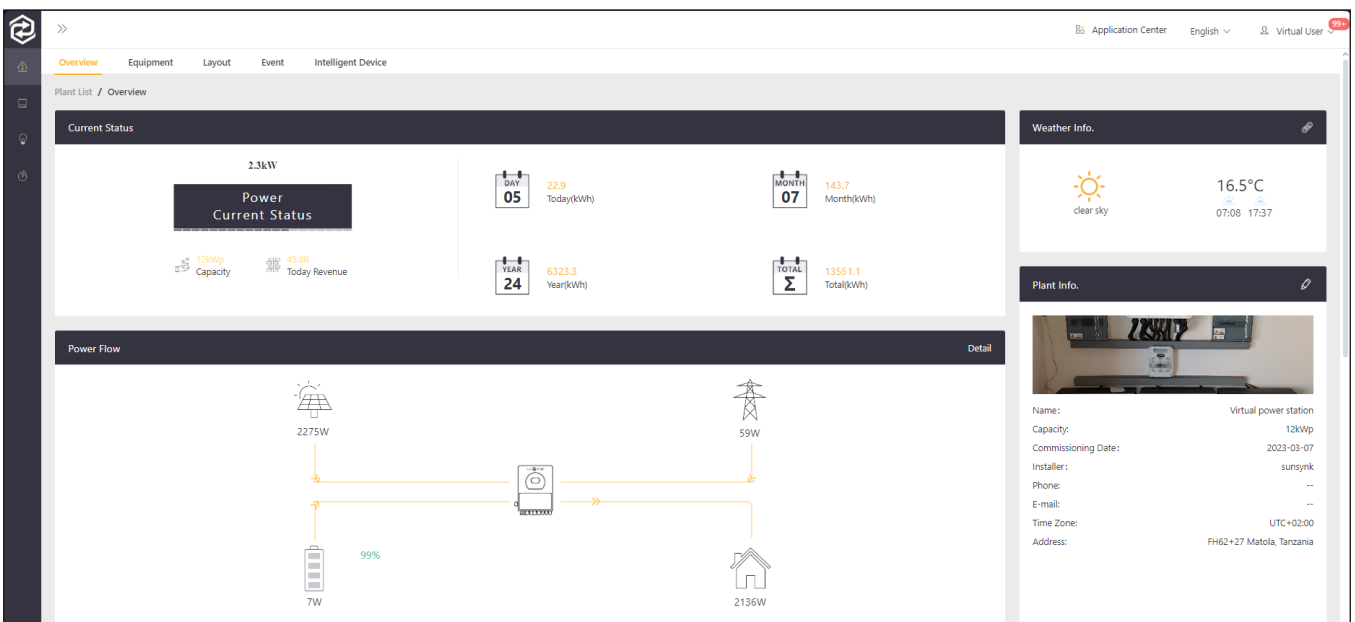
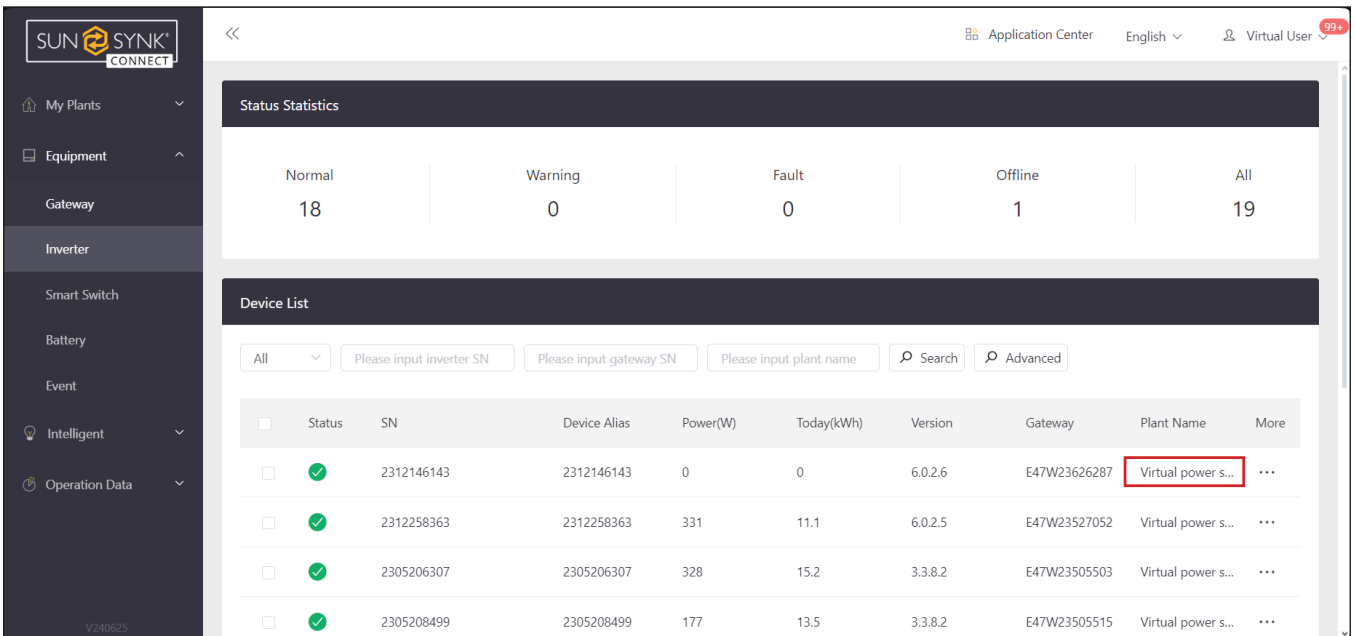

4 Click the 'More (...)' button to set an alias for the device, adjust inverter settings/parameters, or delete a device, as illustrated in the figure below.

The screenshot displays the SUN SYNK CONNECT web interface. On the left is a dark sidebar with navigation options: My Plants, Equipment, Gateway, Inverter (selected), Smart Switch, Battery, Event, Intelligent, and Operation Data. The main content area is titled 'Application Center' and 'Virtual User'. It features a 'Status Statistics' section with a bar chart showing counts for Normal (18), Warning (0), Fault (0), Offline (1), and All (19). Below this is a 'Device List' table with search filters and a table of device data. A red box highlights the 'More' menu for the second device, showing options: Set Alias, Settings, and Delete.

Status	SN	Device Alias	Power(W)	Today(kWh)	Version	Gateway	Plant Name	More
✓	2312146143	2312146143	0	0	6.0.2.6	E47W23626287	Virtual power s...	...
✓	2312258363	2312258363	0	11.5	6.0.2.5	E47W23527052	Virtual p	Set Alias Settings Delete
✓	2305206307	2305206307	0	15.4	3.3.8.2	E47W23505503	Virtual p	
✓	2305208499	2305208499	0	13.6	3.3.8.2	E47W23505515	Virtual p	

# COMMISSIONING

## Start-Up / Shutdown Procedure

The inverter must be installed by a qualified and licensed electrical engineer, following the relevant national wiring regulations. Prior to powering on, the installation engineer must complete the following checks:

- Earth bond test.
- RCD (Residual Current Device) test.
- Earth leakage tests.
- Ensure the solar panel Voc voltage does not exceed 480V.
- Verify battery voltage.

Although the maximum allowable PV input voltage is 500V, the 480V limit provides an additional safety margin to protect the system from potential voltage fluctuations or operational variations that could cause damage.

### Power ON Sequence:



1. Switch on the AC.
2. Press the start button.
3. Switch on the battery and battery breaker.
4. Switch on the DC (PV isolator).



### Shutdown Sequence:

1. Switch off the AC.
2. Press the start button.
3. Switch off the battery and battery breaker.
4. Switch off the DC (PV Isolator).

## Inverter Commissioning Info

After you have successfully powered up the inverter, it must be programmed and set up according to the programming feature above.

 <p><b>Solar</b></p>	<p>Check each bond on the solar panels.</p>	<p>Check the VOC does not exceed 480V MPPT Range.</p>	<p>Ensure both MPPTs are balanced.</p>
 <p><b>GRID</b></p>	<p>Measure the supply voltage check it matches the settings of the inverter.</p>	<p>If it falls out of the setting range it will cause the inverse shut down and alarm.</p>	<p>See Grid Setup page.</p>
 <p><b>BATTERY</b></p>	<p>Check the battery charge and discharge is within the C rating of the battery. Too high will damage the battery.</p>		<p>Check the battery BMS is communicating with the inverter.</p>

 <p><b>SYSTEM MODE</b></p>	<p>This is the heart of the system, this controls everything.</p>	<p>Ensure you are familiar with this, if you fully understand the controller you will fully appreciate the capabilities of there inverter.</p>	<p>See section 'Program Charge / Discharge Times'.</p>
 <p><b>ADVANCE</b></p>	<p>This is for paralleling systems, and wind turbine.</p>	<p>If paralleling inverters in 3-Phase check you phase rotation before switching on the AC Load, in 3-Phase the output voltage will increase across phase to 400V.</p>	<p>If using a wind turbine please ensure you have the correct limiting resistor, caps and rectifier.</p>
 <p><b>FAULT CODES</b></p>	<p>Familiarise yourself with common fault codes.</p>		

## GDFI Fault

Before the inverter connects to the grid, it will check the impedance (effective resistance) of the solar PV+ to ground and the impedance of the solar PV- to ground. If either impedance value is found to be less than 33kΩ, the inverter will prevent grid connection and display an F24 error on the LCD. This is a safety feature designed to protect the system and ensure proper grounding.

## MAINTENANCE

The inverter is designed to require minimal maintenance. However, to ensure optimal performance, it is important to follow these maintenance practices:

- **General Cleaning:** At least twice a year, and more frequently in dusty environments (weekly recommended), clean the cooling fans and air ducts to prevent dust accumulation. This will ensure proper ventilation and prevent overheating.
- **Check Fault Codes:** Regularly check the inverter's display for any fault codes. If fault codes are present, they should be addressed immediately to ensure the system operates effectively.
- **Lithium Battery Communication:** Verify that communication with the Lithium battery is functioning correctly. This can be done through the inverter's monitoring system or the battery management system (BMS).
- **Weekly Cleaning:** In environments with high dust accumulation or micro-ants, it is recommended to use micromesh filters. These filters can help keep dust, insects, and other particles out of the inverter's internal components, preventing damage and ensuring proper airflow.

# APPENDIX A

## Definition of RJ45 Ports

The table below provides the details of the wiring for the RJ45 port connections, which are used for communication with various devices:

No.	Colour	RS485/CAN	Meter	DRM
1	Orange&White	485_B	Meter-485_B	DRM1/5
2	Orange	485_A	Meter-485_A	DRM2/6
3	Green&White	GND_485	-	DRM3/7
4	Blue	CAN-H	Meter-485_B	DRM4/8
5	Blue&White	CAN-L	Meter-485_A	REF-GEN/0
6	Green	GND_485	-	COM LOAD/0
7	Brown&White	485_A	Meter-485_A	NetJ1_7
8	Brown	485_B	Meter-485_B	NetJ1_7

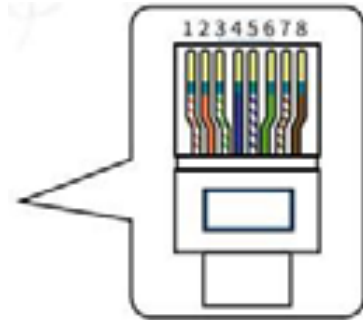

## RS232 Ports

The RS232 port is used to connect the WiFi data logger, allowing communication between the inverter and monitoring systems.

No.	WIFI/RS232
1	
2	TX
3	RX
4	
5	D-GND
6	
7	
8	
9	12Vdc

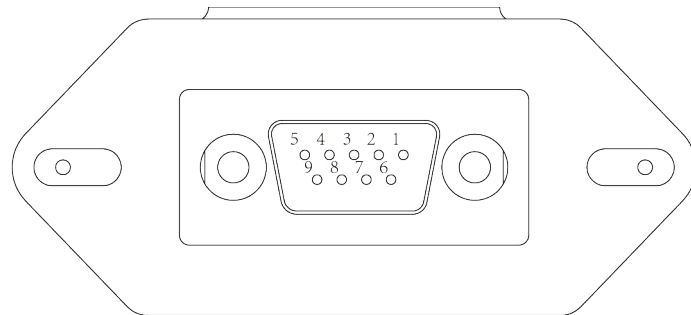

### WIFI/RS232

This RS232 port is used to connect the wifi datalogger

# APPENDIX B

Inverters sold in Australia will be set to the Default Australian standards, ensuring compliance with local regulations and grid compatibility.

# APPENDIX C

The Sunsynk Single-Phase Hybrid Inverter is compatible with the Sunsynk Connect app via Wi-Fi or GSM data logger (see Sunsynk Connect instruction manual for setup details). This integration allows for remote monitoring and control of the inverter system, ensuring ease of use and real-time data access.

## APPENDIX D

---

If an external Residual Current Device (RCD) is used, it should be a Type A/C with a tripping current of 30mA or higher.

### Important Guidelines for Installing RCDs:

1. Disconnect all live conductors (including both active and neutral conductors).
2. Use the type specified in the inverter manufacturer's instructions or as labelled on the inverter.

We recommend the use of an RCD on all circuits and sub-circuits connected to the Sunsynk Inverter. Below are the recommended specifications for a Residual Current Breaker with Overcurrent Protection (RCDO).

Earth-leakage protection class	Type A
Earth-leakage sensitivity	30mA
Curve code	C
Grid type	AC
Poles description	2P
Earth-leakage protection time delay	Instantaneous

## APPENDIX E

---

The Sunsynk inverter can be connected to the internet, but a data logger must be added.

The inverter is compatible with Sunsynk Connect data-loggers, which you can obtain from your distributor.

Available types include:

- LAN-Type Data Logger
- Wi-Fi Type Data Logger
- GSM-Type Data Logger

To set up the internet connection for Sunsynk Connect, please refer to the App User instructions. The Data Logger should be connected to the bottom of the inverter via the connection socket marked WiFi.

For more information on training videos, software updates, help, and forum posts, please visit:

[www.sunsynk.com - Tech Support](http://www.sunsynk.com - Tech Support)

Follow Sunsynk on social media for updates:



Sunsynk



@energysolutions



SunsynkGroup



## Contact Us

---

**Call** +44 151 832 4300 **Email** [sales@sunsynk.com](mailto:sales@sunsynk.com) **Website** [www.sunsynk.com](http://www.sunsynk.com)

- Address**
- HK** Room 702-704, 7/F Texwood Plaza, 6 How Ming Street, Kwun Tong, Kowloon, Hong Kong
  - UK** Sunsynk UK Ltd, 17 Turnstone Business Park, Mulberry Avenue, Widnes, Cheshire, WA8 0WN
  - SA** Stand 375, Northland Business Park, Angus Crecent Road, Hoogland, Randburg, Johannesburg
  - NL** Sunsynk NL BV, Henri Wijnmalenweg 8, 5657 EP Eindhoven, Netherlands
  - AU** Level 1, 982-988 Wellington Street, West Perth WA 6005, Australia
  - ES** Tafetana, 32 P.I. Las Andoriñas 38639 Las Chafiras Santa Cruz de Tenerife
  - US** 100 S. Ashley Drive, Suite 600, Tampa, Florida, 33602, United States of America