



PowerHill (233kWh)

User Manual

Notice

This manual contains important safety instructions, installation, electrical connections, commissioning, maintenance, and troubleshooting of the equipment.

Save the manual!

This manual must be stored carefully and be available at all times.

Copyright Declaration

All rights to the content of this manual are owned by Dunext Technology Suzhou Co., Ltd. (hereinafter called as 'Dunext'). Any corporation or individual should not plagiarize, partially or fully copy it, and reproduce or distribute it in any form or means without prior written permission from Dunext.

Dunext reserves the right of final interpretation. This manual may be updated according to user' s or customer' s feedback. The information in this manual is subject to change without notice. Every effort has been made to ensure the accuracy of the contents of this manual, but nothing mentioned herein expresses or implies any other information.

Please check our website at [http:// www.dunext.com](http://www.dunext.com) for latest version.

Contents

About This Manual	IV
1 Safety Precautions	1
1.1 Statement	1
1.1.1 Personal Safety.....	2
1.1.2 General Requirements	3
1.1.3 Personnel Requirements	3
1.2 Electrical Safety	4
1.2.1 General Requirements	4
1.2.2 Grounding Requirements.....	6
1.2.3 Cabling Requirements.....	6
1.3 Environment Requirements.....	7
1.3.1 General Requirements	8
1.4 Mechanical Safety.....	9
1.4.1 General Requirements	10
1.4.2 Moving Heavy Objects Safety	10
1.4.3 Work-at-height Safety	11
1.4.4 Ladder Use Safety	12
1.4.5 Hoisting Safety	13
1.4.6 Drilling Safety.....	13
1.5 Product Safety	13
1.5.1 ESS Safety	13
1.5.2 Battery Safety	15
2 Product Introduction	20
2.1 Overview	20
2.2 Appearance.....	20
2.3 Components.....	21
2.3.1 Battery Pack	23
2.3.2 High-voltage Box	24
2.3.3 Power Conversion Module	25
2.3.4 MPPT	26
2.3.5 Liquid Cooling Unit	27
2.3.6 Fire Suppression System.....	29
2.3.7 EMS.....	29
2.4 Working Principles.....	30
2.4.1 Circuit Diagram.....	30
2.4.2 ESS Status	31
2.5 Networking Applications.....	32
2.5.1 On-grid Scenarios	32
2.5.2 PV-Storage Scenarios	33
3 Storage Requirements	35
3.1 ESS Storage and Charging	35
3.2 Charging Operation Instructions.....	36
4 Site Requirements	39
4.1 Site Selection Requirements	39
4.1.1 General Requirements	39

4.1.2 Flood Prevention and Flood Control Requirements	41
4.1.3 Outdoor Requirements	41
4.2 Space Requirements	43
4.3 Foundation Requirements	45
5 Unpacking and Acceptance	48
6 Product Installation	49
6.1 Preparation Before Installation	49
6.1.1 Preparing Tools	49
6.1.2 Inspection Before Installation	51
6.2 ESS Installation	52
7 Cables Installation	59
7.1 Cable Preparation	59
7.2 Grounding Cable Installation	62
7.3 Reserved Port Wiring	62
7.3.1 Parallel Wiring of Multiple PCS	64
7.3.2 EMS Wiring	65
7.4 Power Cable Installation	68
7.4.1 AC Power Cable Installation	68
7.4.2 PV Power Cable Installation (Only for MPPT Use)	69
8 ESS Power-On and Power-Off	71
8.1 Check Before Power-On	71
8.1.1 General Check	71
8.1.2 ESS Installation and Check	72
8.2 Power-On and Power-Off Operations	73
9 System Commissioning	76
9.1 Local Startup	76
9.2 IP Address Settings	76
9.3 Scheduling Instructions	77
10 Human-Computer Interaction	80
10.1 Function Overview	80
10.1.1 Monitoring	81
10.1.2 Energy MGT	86
10.1.3 Device Data	89
10.1.4 Device MGT	92
10.1.5 System	94
11 Operation, Maintenance, and Troubleshooting	97
11.1 Monthly Operation & Maintenance Requirements	98
11.2 Annual Operation & Maintenance Requirements	99
11.3 Biennial Operation & Maintenance Requirements	100
11.4 ESS Troubleshooting	101
12 Technical Data	102
A Crimp an OT / DT Terminal	104
B How to Repair Paint Damage	107
C Emergency Handling	110
D How to Recycle Used Batteries	112
E Abbreviations	114

About This Manual

Overview

Please read the product manual carefully before installation, operation, or maintenance of the PowerHill (233kWh). This manual contains important safety instructions and installation instructions that must be followed during installation and maintenance of the equipment.

Designation explanation of the PowerHill (233kWh) (example):

PowerHill-P105M120-233kWh

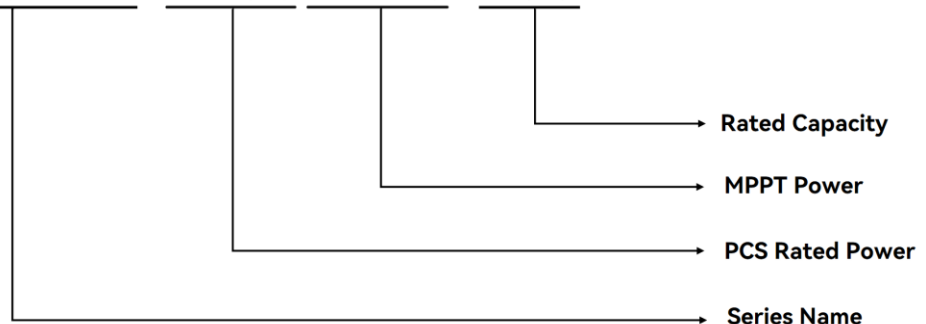







No.	Meaning	Description
1	Series Name	PowerHill: Integrated Outdoor Battery Energy Storage Cabinet
2	PCS Rated Power	P105: System power is 105kW P100: System power is 100kW
3	MPPT Power	① M120: 2 MPPT, 60kW for each ② No MPPT
4	Rated Capacity	233: Nominal capacity is 233kWh









Intended Audience



This manual is intended for technical professionals for installation, commissioning and maintenance of the product. The technical personnel have to be familiar with the product, local standards, and electric systems.

Symbol Conventions

The following types of safety instructions and general information appear in this document as described below:

Symbol	Description
	'Danger' indicates a hazard with a high level of risk that, if not avoided, will result in death or serious injury.
	'Warning' indicates a hazard with a medium level of risk that, if not avoided, will result in death or serious injury.
	'Caution' indicates a hazard with a low level of risk that, if not avoided, could result in minor or moderate injury.
<p>NOTICE</p> 	'Notice' indicates a situation that, if not avoided, could result in equipment or property damage.
	'Note' provides tips that are valuable for the optimal operation of the product.
	CE Mark
	Product should not be disposed as normal household waste.

	<p>Signals danger due to electrical shock and indicates the time (5 minutes) to allow after the equipment has been turned off and disconnected to ensure safety.</p>
	<p>Refer to the user manual.</p>
	<p>Product can be recycled.</p>
	<p>Forbidden to break under load</p>
	<p>High voltage inside</p>
	<p>No activation without fire alarm</p>
	<p>No blocking</p>
	<p>No smoking</p>
	<p>No sparks flames</p>

	Fire will cause toxic fumes
	Warning arc flash hazard wear category III PPE
	Warning electric shock

Change History

Changes between document issues are cumulative. The latest document issue contains all the changes made in earlier issues.

Issue 01 (2025-08-26)

This issue is used for first application

Issue 02 (2025-09-11)

Updated the description and figures in Chapter 7.3, the description in Table 9-1, and the parameters in Chapter 12

Issue 03 (2025-11-18)

Added the description of fire clay in Table 7-1

Issue 04 (2025-12-22)

Updated the description in Chapter 8.2 and 3.2

Issue 05 (2026-01-06)

Updated the description of WAN2 function in Table 7-2

1 Safety Precautions

1.1 Statement

- Before transporting, storing, installing, operating, using, and/or maintaining the equipment, read this document, strictly follow the instructions provided herein, and follow all the safety instructions on the equipment and in this document. In this document, "equipment" refers to the products, software, components, spare parts, and/or services related to this document; "the Company" refers to the manufacturer (producer), seller, and/or service provider of the equipment; "you" refers to the entity that transports, stores, installs, operates, uses, and/or maintains the equipment.
- The Danger, Warning, Caution, and Notice statements described in this document do not cover all the safety precautions. You also need to comply with relevant international, national, or regional standards and industry practices. The Company shall not be liable for any consequences that may arise due to violations of safety requirements or safety standards concerning the design, production, and usage of the equipment.
- The equipment shall be used in an environment that meets the design specifications. Otherwise, the equipment may be faulty, malfunctioning, or damaged, which is not covered under the warranty. The Company shall not be liable for any property loss, personal injury, or even death caused thereby.
- Comply with applicable laws, regulations, standards, and specifications during transportation, storage, installation, operation, use, and maintenance.
- Do not perform reverse engineering, decompilation, disassembly, adaptation, implantation, or other derivative operations on the equipment software. Do not study the internal implementation logic of the equipment, obtain the source code of the equipment software, violate intellectual property rights, or disclose any of the performance test results of the equipment software.

The Company shall not be liable for any of the following circumstances or their consequences:

- The equipment is damaged due to force majeure such as earthquakes, floods, volcanic eruptions, debris flows, lightning strikes, fires, wars, armed conflicts, typhoons, hurricanes, tornadoes, and other extreme weather conditions.
- The equipment is operated beyond the conditions specified in this document.
- The equipment is installed or used in environments that do not comply with international, national, or regional standards.
- The equipment is installed or used by unqualified personnel.
- Fail to follow the operation instructions and safety precautions on the product and in the document.
- Remove or modify the product or modify the software code without authorization.
- You or a third party authorized by you cause the equipment damage during transportation.
- The equipment is damaged due to storage conditions that do not meet the requirements specified in the product document.
- You fail to prepare materials and tools that comply with local laws, regulations, and related standards.
- The equipment is damaged due to your or a third party's negligence, intentional breach, gross negligence, or improper operations, or other reasons not related to the Company.

1.1.1 Personal Safety



- Ensure that power is off during installation. Do not install or remove a cable with power on. Transient contact between the core of the cable and the conductor will cause electric arcs, sparks, fire, or explosion, which may result in personal injury.
- Non-standard and improper operations on the energized equipment may cause fire, electric shocks, or explosion, resulting in property damage, personal injury, or even death.
- Before operations, remove conductive objects such as watches, bracelets, bangles, rings, and necklaces to prevent electric shocks.
- During operations, use dedicated insulated tools to prevent electric shocks or short circuits. The dielectric withstanding

	voltage level must comply with local laws, regulations, standards, and specifications.
 WARNING!	When operating the system, appropriate personal protective equipment (PPE) compliant with local standards should be worn, such as protective clothing, insulated shoes, goggles, a safety helmet, and insulated gloves.

1.1.2 General Requirements



- Do not stop protective devices. Pay attention to the warnings, cautions, and related precautionary measures in this document and on the equipment.
- If there is a likelihood of personal injury or equipment damage during operations, immediately stop, report the case to the supervisor, and take feasible protective measures.
- Do not power on the equipment before it is installed or confirmed by professionals.
- Do not touch the power supply equipment directly or with conductors such as damp objects. Before touching any conductor surface or terminal, measure the voltage at the contact point to ensure that there is no risk of electric shock.
- Do not touch operating equipment because the enclosure is hot.
- Do not touch a running fan with your hands, components, screws, tools, or boards. Otherwise, personal injury or equipment damage may occur.
- In the case of a fire, immediately leave the building or the equipment area and activate the fire alarm or call emergency services. Do not enter the affected building or equipment area under any circumstances.

1.1.3 Personnel Requirements

- Only professionals and trained personnel are allowed to operate the equipment.
 - Professionals: personnel who are familiar with the working principles and structure of the equipment, trained or experienced in equipment operations and are clear of the sources and degree of various potential hazards in equipment installation, operation, maintenance.
 - Trained personnel: personnel who are trained in technology and safety, have required experience, are aware of possible hazards on themselves in certain operations, and are able to take protective measures to minimize the hazards on themselves and other people.
- Personnel who plan to install or maintain the equipment must receive adequate training, be able to correctly perform all operations, and understand all necessary safety precautions and local relevant standards.

- Only qualified professionals or trained personnel are allowed to install, operate, and maintain the equipment.
- Only qualified professionals are allowed to remove safety facilities and inspect the equipment.
- Personnel who will perform special tasks such as electrical operations, working at heights, and operations of special equipment must possess the required local qualifications.
- Only certified high-voltage electricians are allowed to operate medium voltage equipment.
- Only authorized professionals are allowed to replace the equipment or components (including software).
- Only personnel who need to work on the equipment are allowed to access the equipment.

1.2 Electrical Safety

	<ul style="list-style-type: none"> ● Before connecting cables, ensure that the equipment is intact. Otherwise, electric shocks or fire may occur. ● Non-standard and improper operations may result in fire or electric shocks. ● Prevent foreign matter from entering the equipment during operations. Otherwise, equipment short-circuits or damage, load power derating, power failure, or personal injury may occur.
	<p>For the equipment that needs to be grounded, install the ground cable first when installing the equipment and remove the ground cable last when removing the equipment.</p>
	<p>Do not route cables near the air intake or exhaust vents of the equipment.</p>

1.2.1 General Requirements

- Follow the procedures described in the document for installation, operation, and maintenance. Do not reconstruct or alter the equipment, add components, or change the installation sequence without permission.

- Obtain approval from the national or local electric utility company before connecting the equipment to the grid.
- Observe the power plant safety regulations, such as the operation and work ticket mechanisms.
- Install temporary fences or warning ropes and hang "No Entry" signs around the operation area to keep unauthorized personnel away from the area.
- Before installing or removing power cables, turn off the switches of the equipment and its upstream and downstream switches.
- If there is any electrolyte or coolant leakage inside the equipment, disconnect the power supply immediately and do not use the equipment.
- Before performing operations on the equipment, check that all tools meet the requirements and record the tools. After the operations are complete, collect all of the tools to prevent them from being left inside the equipment.
- Before installing the power cables, check that the cable labels are correct and that the cable terminals are securely connected.
- When installing the equipment, use a torque tool of a proper measurement range to tighten the screws. When using a wrench to tighten the screws, ensure that the wrench does not tilt and the torque error does not exceed 10% of the specified value.
- Ensure that bolts are tightened with a torque tool and marked in red and blue after double-check. Installation personnel mark tightened bolts in blue. Quality inspection personnel confirm that the bolts are tightened and then mark them in red, as shown in the figure below. (The marks must cross the edges of the bolts.)

Figure 1-1 Bolts Tightening Marks

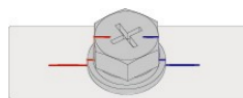

- After the installation is complete, ensure that protective cases, insulation tubes, and other necessary items for all electrical components are in position to avoid electric shocks.
- If the equipment has multiple inputs, disconnect all the inputs before operating the equipment.
- Before maintaining a downstream electrical or power distribution device, turn off the output switch on the power supply equipment.
- During equipment maintenance, attach "Do not switch on" labels near the upstream and downstream switches or circuit breakers as well as warning

signs to prevent accidental connection. The equipment can be powered on only after troubleshooting is complete.

- If fault diagnosis and troubleshooting need to be performed after power-off, take the following safety measures: Disconnect the power supply. Check whether the equipment is live. Install a ground cable. Hang warning signs and set up fences.
- Check equipment connections periodically, ensuring that all screws are securely tightened.
- Only qualified professionals can replace a damaged cable.
- Do not scrawl, damage, or block any labels or nameplates on the equipment. Promptly replace labels that have worn out.
- Do not use solvents such as water, alcohol, or oil to clean electrical components inside or outside of the equipment.

1.2.2 Grounding Requirements

- Ensure that the grounding impedance of the equipment complies with local electrical standards.
- Ensure that the equipment is connected permanently to the protective ground. Before operating the equipment, check its electrical connection to ensure that it is reliably grounded.
- Do not work on the equipment in the absence of a properly installed ground conductor.
- Do not damage the ground conductor.
- If high touch current may occur on the equipment, ground the protective ground terminal on the equipment enclosure before connecting the power supply; otherwise, electric shock as a result of touch current may occur.

1.2.3 Cabling Requirements

- When selecting, installing, and routing cables, follow local safety regulations and rules.
- When routing power cables, ensure that there is no coiling or twisting. Do not join or weld power cables. If necessary, use a longer cable.
- Ensure that all cables are properly connected and insulated, and meet specifications.
- Ensure that the slots and holes for routing cables are free from sharp edges, and that the positions where cables are routed through pipes or cable holes

are equipped with cushion materials to prevent the cables from being damaged by sharp edges or burrs.

- If a cable is routed into the cabinet from the top, bend the cable in a U shape outside the cabinet and then route it into the cabinet.
- Ensure that cables of the same type are bound together neatly and straight and that the cable sheath is intact. When routing cables of different types, ensure that they are at least 30 mm away from each other.
- When cable connection is completed or paused for a short period of time, seal the cable holes with sealing putty immediately to prevent small animals or moisture from entering.
- Secure buried cables using cable supports and cable clips. Ensure that the cables in the backfill area are in close contact with the ground to prevent cable deformation or damage during backfilling.
- If the external conditions (such as the cable layout or ambient temperature) change, verify the cable usage in accordance with the IEC-60364-5-52 or local laws and regulations. For example, check that the current-carrying capacity meets requirements.
- When routing cables, reserve at least 30 mm clearance between the cables and heat-generating components or areas. This prevents deterioration or damage to the cable insulation layer.
- When the temperature is low, violent impact or vibration may damage the plastic cable sheathing. To ensure safety, comply with the following requirements:
 - Cables can be laid or installed only when the temperature is higher than 0°C. Handle cables with caution, especially at a low temperature.
 - Cables stored at below 0°C must be stored at room temperature for more than 24 hours before they are laid out.
- It is forbidden to directly push the cable from the car and other non-standard operations, to avoid the damage of the cable performance decline, affecting the current load and temperature rise.

1.3 Environment Requirements



- Do not expose the equipment to flammable or explosive gas or smoke. Do not perform any operation on the equipment in such environments.
- Do not store any flammable or explosive materials in the equipment area.
- Do not place the equipment near heat sources or fire sources, such as smoke, candles, heaters, or other heating

	devices. Overheat may damage the equipment or cause a fire.
	<ul style="list-style-type: none"> ● Install the equipment in an area far away from liquids. Do not install it under areas prone to condensation, such as under water pipes and air exhaust vents, or areas prone to water leakage, such as air conditioner vents, ventilation vents, or feeder windows of the equipment room. Ensure that no liquid enters the equipment to prevent faults or short circuits. ● To prevent damage or fire due to high temperature, ensure that the ventilation vents or heat dissipation systems are not obstructed or covered by other objects while the equipment is running.



1.3.1 General Requirements

- Ensure that the equipment is stored in a clean, dry, and well-ventilated area with proper temperature and humidity and is protected from dust and condensation.
- Keep the installation and operating environments of the equipment within the allowed ranges. Otherwise, its performance and safety will be compromised.
- Do not install, use, or operate outdoor equipment and cables (including but not limited to moving equipment, operating equipment and cables, inserting connectors to or removing connectors from signal ports connected to outdoor facilities, working at heights, performing outdoor installation, and opening doors) in harsh weather conditions such as lightning, rain, snow, and level 6 or stronger wind.
- Do not install the equipment in an environment with dust, smoke, volatile or corrosive gases, infrared and other radiations, organic solvents, or salty air.
- Do not install the equipment in an environment with conductive metal or magnetic dust.
- Do not install the equipment in an area conducive to the growth of microorganisms such as fungus or mildew.
- Do not install the equipment in an area with strong vibration, noise, or electromagnetic interference.
- Ensure that the site complies with local laws, regulations, and related standards.
- Ensure that the ground in the installation environment is solid, free from spongy or soft soil, and not prone to subsidence. The site must not be located

in a low-lying land prone to water or snow accumulation, and the horizontal level of the site must be above the highest water level of that area in history.

- Do not install the equipment in a position that may be submerged in water.
- If the equipment is installed in a place with abundant vegetation, in addition to routine weeding, harden the ground underneath the equipment using cement or gravel.
- Before opening doors during the installation, operation, and maintenance of the equipment, clean up any water, ice, snow, or other foreign objects on the top of the equipment to prevent foreign objects from falling into the equipment.
- When installing the equipment, ensure that the installation surface is solid enough to bear the weight of the equipment.
- All cable holes must be sealed. Seal the used cable holes with sealing putty. Seal the unused cable holes with the caps delivered with the equipment.
- After installing the equipment, remove the packing materials such as cartons, foam, plastics, and cable ties from the equipment area.

1.4 Mechanical Safety

	<p>When working at heights, wear a safety helmet and safety harness or waist belt and fasten it to a solid structure. Do not mount it on an insecure moveable object or metal object with sharp edges. Make sure that the hooks will not slide off.</p>
	<ul style="list-style-type: none"> ● Ensure that all necessary tools are ready and inspected by a professional organization. Do not use tools that have signs of scratches or fail to pass the inspection or whose inspection validity period has expired. Ensure that the tools are secure and not overloaded. ● Before installing equipment in a cabinet, ensure that the cabinet is securely fastened with a balanced centre of gravity. Otherwise, tipping or falling cabinets may cause bodily injury and equipment damage. ● When pulling equipment out of a cabinet, be aware of unstable or heavy objects in the cabinet to prevent injury. ● Do not drill holes into the equipment. Doing so may affect the sealing performance and electromagnetic containment of the equipment and damage components or cables inside. Metal shavings from drilling may short-circuit boards inside the equipment.

1.4.1 General Requirements

- Repaint any paint scratches caused during equipment transportation or installation in a timely manner. Equipment with scratches must not be exposed for an extended period of time.
- Do not perform operations such as arc welding and cutting on the equipment without evaluation by the Company.
- Do not install other devices on the top of the equipment without evaluation by the Company.
- When performing operations over the top of the equipment, take measures to protect the equipment against damage.
- Use correct tools and operate them in the correct way.

1.4.2 Moving Heavy Objects Safety

- Be cautious to prevent injury when moving heavy objects, follow instructions in the figure below.

Figure 1-2 Moving Heavy Objects Instructions

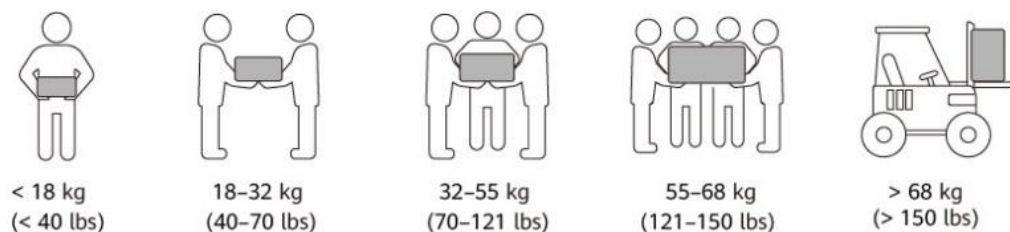

- If multiple persons need to move a heavy object together, determine the manpower and work division with consideration of height and other conditions to ensure that the weight is equally distributed.
- If two persons or more move a heavy object together, ensure that the object is lifted and landed simultaneously and moved at a uniform pace under the supervision of one person.
- Wear personal protective gears such as protective gloves and shoes when manually moving the equipment.
- To move an object by hand, approach to the object, squat down, and then lift the object gently and stably by the force of the legs instead of your back. Do not lift it suddenly or turn your body around.

- Move or lift the equipment by holding its handles or lower edges. Do not hold the handles of modules that are installed in the equipment.
- Do not quickly lift a heavy object above your waist. Place the object on a workbench that is half-waist high or any other appropriate place, adjust the positions of your palms, and then lift it.
- Move a heavy object stably with balanced force at an even and low speed. Put down the object stably and slowly to prevent any collision or drop from scratching the surface of the equipment or damaging the components and cables.
- When moving a heavy object, be aware of the workbench, slope, staircase, and slippery places. When moving a heavy object through a door, ensure that the door is wide enough to move the object and avoid bumping or injury.
- When transferring a heavy object, move your feet instead of turning your waist around. When lifting and transferring a heavy object, ensure that your feet point to the target direction of movement.
- When transporting the equipment using a pallet truck or forklift, ensure that the tynes are properly positioned so that the equipment does not topple. Before moving the equipment, secure it to the pallet truck or forklift using ropes. When moving the equipment, assign dedicated personnel to take care of it.
- Choose sea or roads in good conditions for transportation. Do not transport the equipment by railway or air. Avoid tilt or jolt during transportation.
- When moving and transporting an air conditioner, keep it upright and do not place it horizontally or upside down. If the package of the air conditioner is damaged or the tilt indicator on the package changes color, contact Dunext's service engineers.

1.4.3 Work-at-height Safety

- Any operations performed 2m or higher above the ground shall be supervised properly.
- Only trained and qualified personnel are allowed to work at heights.
- Do not work at heights when steel pipes are wet or other risky situations exist. After the preceding conditions no longer exist, the safety owner and relevant technical personnel need to check the involved equipment. Operators can begin working only after safety is confirmed.
- Set a restricted area and prominent signs for working at heights to warn away irrelevant personnel.
- Set guard rails and warning signs at the edges and openings of the area involving working at heights to prevent falls.

- Do not pile up scaffolding, springboards, or other objects on the ground under the area involving working at heights. Do not allow people to stay or pass under the area involving working at heights.
- Carry operation machines and tools properly to prevent equipment damage or personal injury caused by falling objects.
- Personnel involving working at heights are not allowed to throw objects from the height to the ground, or vice versa. Objects shall be transported by slings, hanging baskets, aerial work platforms, or cranes.
- Do not perform operations on the upper and lower layers at the same time. If unavoidable, install a dedicated protective shelter between the upper and lower layers or take other protective measures. Do not pile up tools or materials on the upper layer.
- Dismantle the scaffolding from top down after finishing the job. Do not dismantle the upper and lower layers at the same time. When removing a part, ensure that other parts will not collapse.
- Ensure that personnel working at heights strictly comply with the safety regulations. The Company is not responsible for any accident caused by violation of the safety regulations on working at heights.
- Behave cautiously when working at heights. Do not rest at heights.

1.4.4 Ladder Use Safety

- Use wooden or insulated ladders when you need to perform live-line working at heights.
- Platform ladders with protective rails are preferred. Do not use single ladders.
- Before using a ladder, check that it is intact and confirm its load bearing capacity. Do not overload it.
- Ensure that the ladder is securely positioned and held firm, as shown in the figure below.

Figure 1-3 Ladder Holding Example



- When climbing up the ladder, keep your body stable and your center of gravity between the side rails, and do not overreach to the sides.
- When a step ladder is used, ensure that the pull ropes are secured.

1.4.5 Hoisting Safety

- Only trained and qualified personnel are allowed to perform hoisting operations.
- The hoisting area is to be isolated by erecting temporary warning signs or fences.
- Ensure that the foundation where hoisting is performed on meets the load bearing requirements.
- Before hoisting objects, ensure that hoisting tools are firmly secured onto a fixed object or wall that meets the load-bearing requirements.
- During hoisting, it is strictly prohibited to stand or walk under the crane or hoisted object.
- Do not drag steel ropes and hoisting tools or bump the hoisted objects against hard objects during hoisting.

1.4.6 Drilling Safety



- Obtain consent from the client and contractor before drilling.
- Wear protective equipment such as safety goggles and protective gloves when drilling holes.
- To avoid short circuits or other risks, do not drill holes into buried pipes or cables.
- When drilling holes, the equipment should be shielded and protected to prevent debris from falling into the equipment, and debris should be cleaned up in time after drilling.

1.5 Product Safety

1.5.1 ESS Safety



- Do not open the cabinet door when the system is running.
- When the energy storage system is faulty, DO NOT stand at the cabinet door (including the open range of the cabinet door).

	<ul style="list-style-type: none"> ● The energy storage system is an enclosed system and will not release any gases under normal operations. If the energy storage system is improperly treated, for example, burnt, struck by lightning, overcharged, or subject to other adverse conditions that may cause battery thermal runaway, the system may be damaged or an abnormal chemical reaction may occur inside the battery, resulting in electrolyte leakage or production of gases such as CO and H₂. To prevent fire or device corrosion, ensure that flammable gas is properly exhausted.
 WARNING!	<ul style="list-style-type: none"> ● Before unpacking, storage, and transportation, ensure that the packing cases are intact and the energy storage system are correctly placed according to the labels on the packing cases. ● Install the energy storage system in a dry area. Do not install it under areas prone to water leakage, such as air conditioner vents, ventilation vents, feeder windows of the equipment room, or water pipes. Ensure that no liquid enters the equipment to prevent faults or short circuits. ● Before installing and commissioning the energy storage system, prepare firefighting facilities, such as fire sand and carbon dioxide fire extinguishers, according to construction standards and regulations. Before putting into operation, ensure that firefighting facilities that comply with local laws and regulations are installed. ● Tighten the screws on copper bars or cables to the torque specified in this document. Periodically confirm whether the screws are tightened, check for rust, corrosion, or other foreign objects, and clean them up if any. Loose screw connections will result in excessive voltage drops and batteries may catch fire when the current is high. ● After the energy storage system is discharged, the system should be charged in time, otherwise the battery inside the system may be damaged due to over discharge.
 CAUTION!	<p>Once the buzzer is triggered, evacuate from the site immediately.</p>
NOTICE NOTICE!	<p>Take protection and isolation measures for the energy storage system, such as installing fences, walls, and safety warning signs to prevent personal injury or property damage caused by unauthorized access during operations.</p>

- When installing the energy storage system, comply with the fire separation distance or fire wall requirements specified in local standards, including but not limited to NFPA 855 Standard for the Installation of Stationary Energy Storage Systems.
- When inspecting the system with power on, pay attention to the hazard warning signs on the equipment and DO NOT stand at the cabinet door.
- It is recommended that you prepare camera devices to record the detailed process of installation, operation and maintenance of the equipment.

1.5.2 Battery Safety



- Do not connect the positive and negative poles of a battery together. Otherwise, the battery may be short-circuited. Battery short circuits can generate high instantaneous current and releases a large amount of energy, which may cause battery leakage, smoke, flammable gas release, thermal runaway, fire, or explosion. To avoid battery short circuits, do not maintain batteries with power on.
- Do not expose batteries at high temperatures or around heat sources, such as fire sources, transformers, and heaters. Battery overheating may cause leakage, smoke, flammable gas release, thermal runaway, fire, or explosion.
- The battery is strictly prohibited from fall, collision, hard object puncture and pressure impact, otherwise it may lead to battery damage or fire.
- To avoid leakage, smoke, flammable gas release, thermal runaway, fire, or explosion, do not disassemble, alter, or damage batteries, for example, insert foreign objects into batteries, squeeze batteries, or immerse batteries in water or other liquids.
- It is strictly prohibited to touch the battery terminals with other metal objects, which may cause heat generation or electrolyte leakage.
- There is a risk of fire or explosion if the model of the battery in use or used for replacement is incorrect. Use a battery of the model recommended by the manufacturer.
- Battery electrolyte is toxic and volatile. Do not get contact with leaked liquids or inhale gases in the case of battery leakage or odor. In such cases, stay away from the battery and contact professionals immediately. Professionals must wear safety goggles, rubber gloves, gas masks, and protective clothing, power off the equipment, remove the battery, and contact

	technical engineers. <ul style="list-style-type: none"> ● Gases from burning batteries can irritate eyes, skin and throat. Take protective measures promptly.
--	--

1.5.2.1 Statement

The Company shall not be liable for any battery damage, personal injury, death, property loss, and/or other consequences caused by the following reasons:

- Force majeure such as earthquakes, floods, volcanic eruptions, debris flows, lightning strikes, fires, wars, armed conflicts, typhoons, hurricanes, tornadoes, and other extreme weather conditions
- The battery warranty period has expired. You are advised not to use a battery whose warranty period has expired, as this poses safety risks.
- Actions that do not follow instructions in the user manual or direct advice from the Company, including but not limited to the following scenarios:

The onsite equipment operating environment or external power parameters do not meet the environment requirements for normal operation, for example, the actual operating temperature of batteries is too high or too low, or the power grid is unstable and experiences outages frequently.

- Batteries are dropped or incorrectly operated or connected.
- Batteries are over discharged due to delayed acceptance or power-on after battery installation.
- Battery running parameters are incorrectly set.
- Different types of batteries, for example, batteries of different brands or rated capacities, are used together without prior approval from the Company.
- Batteries are frequently overdischarged due to improper battery maintenance or operation.
- Battery use scenarios are changed without prior approval from the Company.
- Battery maintenance is not performed according to the instructions in the user manual, for example, failing to check battery terminals regularly.
- Batteries are not transported, stored, or charged according to the instructions in the user manual.
- Instructions from the Company are not followed during battery relocation or reinstallation.

1.5.2.2 General Requirements

NOTICE
NOTICE!

To ensure battery safety and battery management accuracy, use batteries provided by the Company. The Company is not responsible for any faults of batteries not provided by it.

- Before installing, operating, and maintaining batteries, read the battery manufacturer's instructions and comply with their requirements. The safety precautions specified in this document are highly important and require special attention. For additional safety precautions, see the instructions provided by the battery manufacturer.
- Do not use a damaged battery (such as damage caused when a battery is dropped, bumped, bulged, or dented on the enclosure), because the damage may cause electrolyte leakage or flammable gas release. In the case of electrolyte leakage or structural deformation, contact the installer or professional O&M personnel immediately to remove or replace the battery. Do not store the damaged battery near other devices or flammable materials and keep it away from non-professionals.
- Before battery operation, make sure there are no irritating, burning or other scorched smell around the battery.
- It is strictly prohibited to place installation tools, metal parts and sundries on the battery during installation. After the installation is completed, clean up the items on and around the battery in a timely manner.
- Prohibit the installation of the battery pack in rain, snow, fog and other weather to avoid the battery pack being eroded by moisture and rain.
- If the battery is accidentally drenched in water, it is prohibited to continue installation. Transport it to a safe isolation point and promptly scrap it for disposal.
- Check whether the positive and negative battery terminals are grounded unexpectedly. If so, disconnect the battery terminals from the ground.
- Do not perform welding or grinding work around batteries to prevent fire caused by electric sparks or arcs.
- If batteries are left unused for a long period of time, store and charge them according to the battery requirements.
- Prohibit the use of equipment for charging and discharging that does not meet the requirements of local laws, regulations and codes.
- Keep the battery circuit disconnected during installation and maintenance.
- Monitor damaged batteries during storage for signs of smoke, flame, electrolyte leakage, or heat.
- If a battery is faulty, its surface temperature may be high. Do not touch the battery to avoid scalds.

- Do not stand on, lean on, or sit on the top of the equipment.
- In backup power scenarios, do not use the batteries for the following situations:
 - Medical devices substantially important to human life
 - Control equipment such as trains and elevators, as this may cause personal injury
 - Computer systems of social and public importance
 - Locations near medical devices
 - Other devices similar to those described above

1.5.2.3 Short Circuit Protection

- When installing and maintaining the battery, you need to wrap the exposed cable terminals on the battery with insulation tape.
- Avoid foreign bodies (such as conductive objects, screws, liquids, etc.) from entering the battery and causing a short circuit.

1.5.2.4 Leakage Handling

NOTICE 	Electrolyte leakage may damage the equipment. It will corrode metal parts and boards, and ultimately damage the boards.
--	---

The electrolyte is corrosive and can cause skin irritation and chemical burns. If you come into direct contact with the battery electrolyte, take the following measures:

- Inhalation: Evacuate from contaminated areas, get fresh air immediately, and seek immediate medical attention.
- Eye contact: Immediately flush eyes with plenty of water for at least 15 minutes, do not rub, and seek immediate medical help.
- Skin contact: Wash the affected areas immediately with soap and water and seek immediate medical attention.
- Intake: Seek immediate medical help.

1.5.2.5 Recycling

- Please dispose of used batteries in accordance with local laws and regulations, and do not dispose of batteries as household waste. Improper disposal of batteries may lead to environmental pollution or explosion.
- If a battery leaks or is damaged, contact technical support or a battery recycling company for disposal.

- When the batteries are out of service life, contact a battery recycling company for disposal.
- Avoid exposing waste batteries to high temperatures or direct sunlight.
- Avoid exposing waste batteries to high humidity or corrosive environments.
- Do not use faulty batteries and must be reported to a battery recycling company for disposal as soon as possible to avoid environmental pollution.

2 Product Introduction

2.1 Overview

PowerHill (233kWh) is an integrated outdoor battery energy storage cabinet including battery, BMS, PCS, MPPT (optional), auxiliary power system, fire suppression system, liquid cooling system and grounding system.

2.2 Appearance

Figure 2-1 Appearance and Dimensions

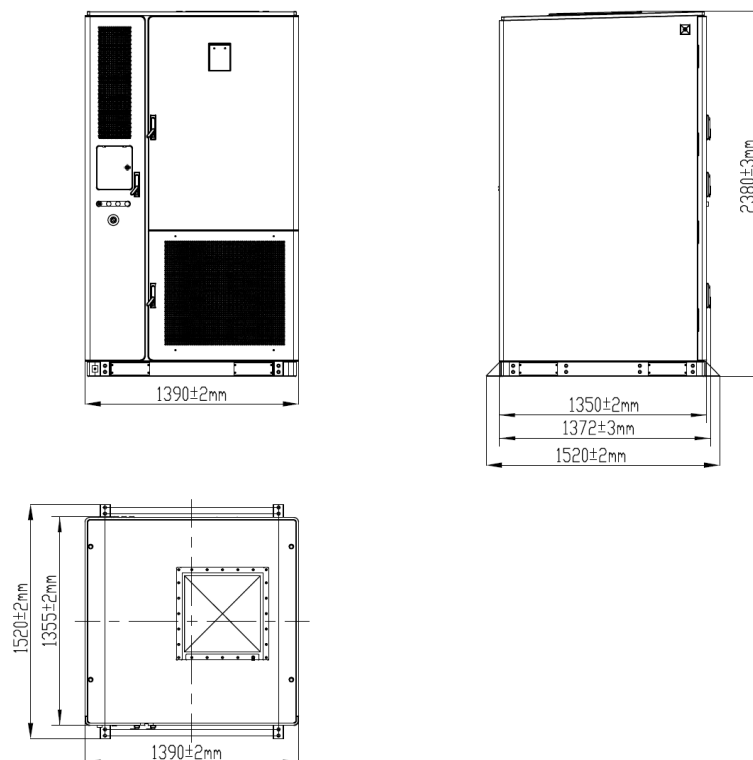

2.3 Components

Figure 2-2 Components (Door Closed)

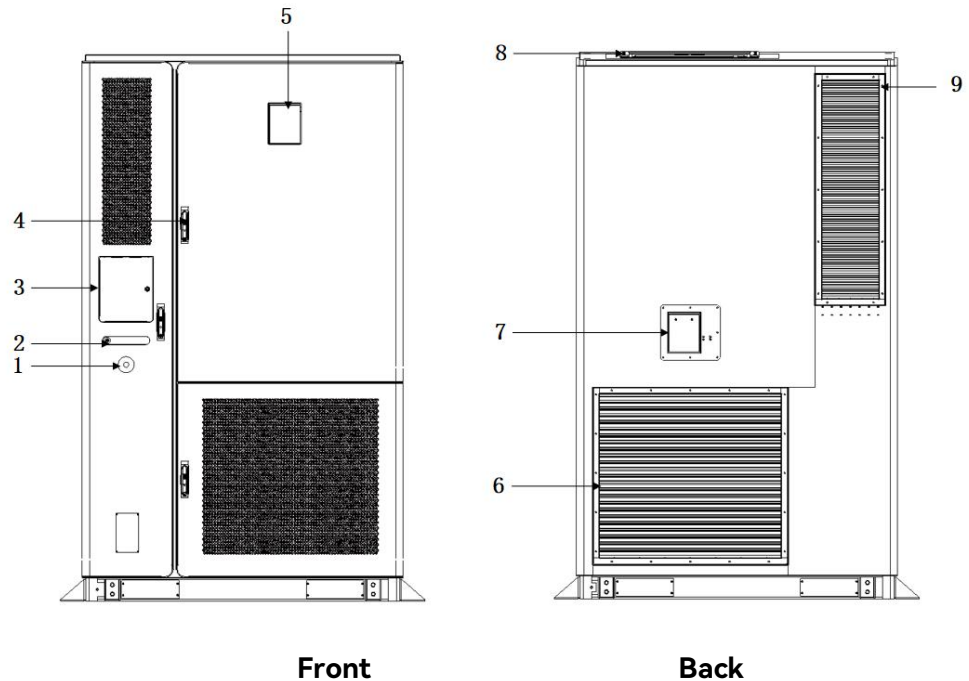
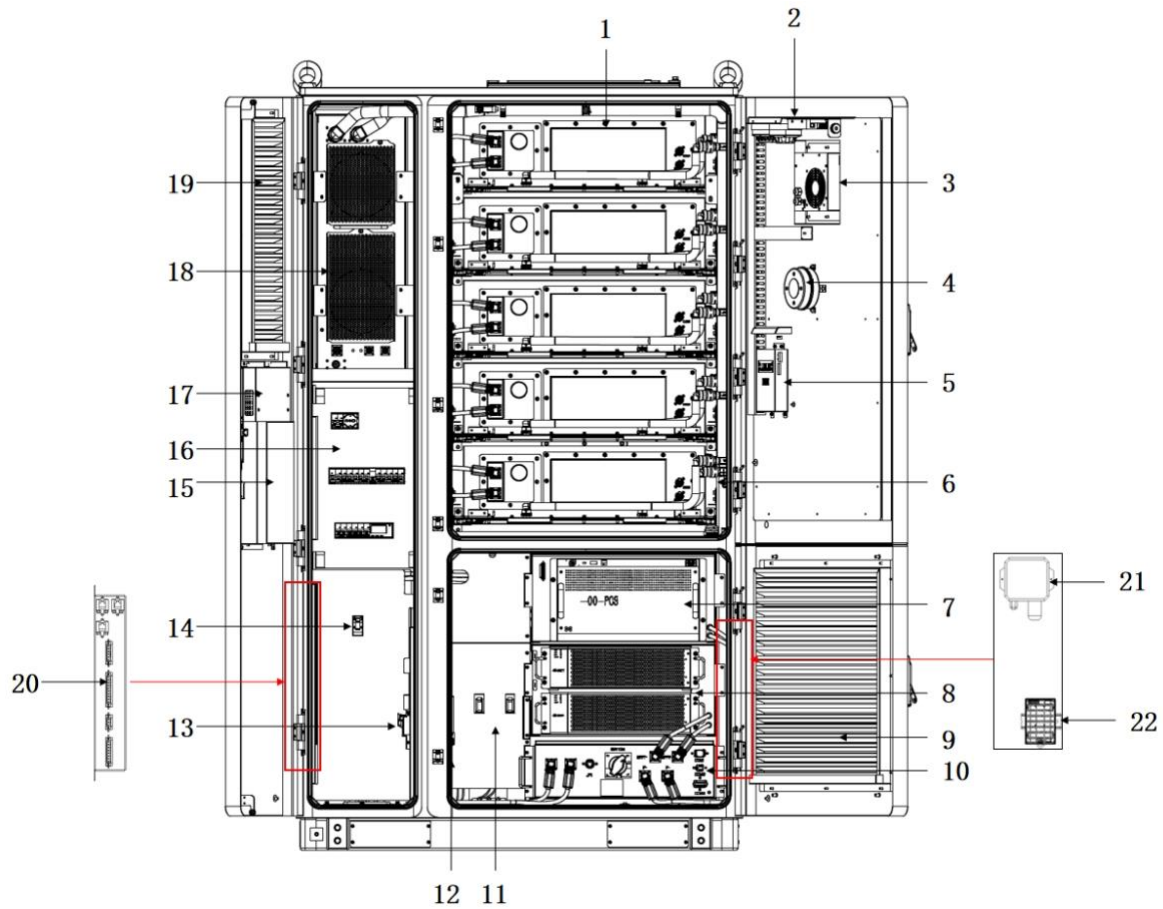

Table 2-1 Component (Door Closed)

No.	Item	Description
1	Emergency stop switch	For system emergency stops
2	Buzzer and indicator light	Indicate system alarm status
3	EMS cover	For EMS protection
4	Door lock	For door lock
5	Exhaust fan	Exhaust combustible gases from the cabinet
6	Electrical cabinet rear air inlet	Cools electrical components such as PCS, MPPT, etc.
7	Air inlet	Allows rapid airflow into the cabinet in case of thermal runaway
8	Deflagration panel	Relieve explosion pressure
9	Electrical cabinet rear air outlet	Cools the liquid cooling unit

Figure 2-3 Components (Door Opened)

Table 2-2 Components (Door Opened)

No.	Item	Description
1	Battery pack	1P52S/280Ah-0.5P
2	Smoke detector, temperature sensor, combustible gas detector (optional)	Smoke detector: Detects the current concentration of smoke in the environment Temperature sensor: Detects the current ambient temperature Combustible gas detector: Detects the concentration of combustible gases (H ₂ and CO)
3	Exhaust fan	Exhaust combustible gases from the cabinet
4	Cabinet-level aerosol	Suppresses thermal runaway inside the cabinet
5	Dehumidifier	Dehumidifies the cabinet
6	Liquid cooling pipes	Serves as the circulation medium for liquid cooling
7	PCS	For DC/AC conversion
8	MPPT	For PV connection
9	Electrical cabinet front air inlet	Cools electrical components such as PCS, MPPT, etc.
10	High-voltage box	Monitors battery status and controls battery circuit in

No.	Item	Description
		real time
11	PV side circuit breaker	PV side circuit breaker
12	PV side surge protector	Surge protection for PV side circuit
13	AC surge protector	Surge protection for AC side
14	PCS AC circuit breaker	PCS AC circuit breaker
15	Wiring cover	Shields wiring
16	Auxiliary power distribution module	For switch control of AC220V and DC24V powered devices
17	EMS cover	For EMS protection
18	Liquid cooling unit	Heats or cools the battery cell
19	Electrical cabinet front air outlet	Cools the liquid cooling unit
20	Reserved ports	Reserved ports for on-site wiring and commissioning
21	Noise sensor	Detects ambient noise inside the cabinet
22	Water sensor	Monitors water level inside the cabinet

2.3.1 Battery Pack

Figure 2-4 Battery Pack (Front View)

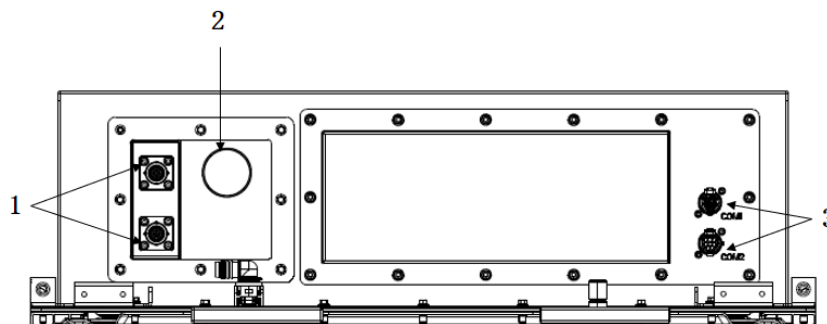

Table 2-3 Battery Pack (Front View)

No.	Item	Description
1	Positive/Negative connectors	Used for high-voltage connections between battery packs
2	Explosion-proof valve	Used to relieve internal pressure from the battery pack
3	Communication ports	Used for communication between PACKs

Table 2-4 Battery Pack Parameters

Item	Battery Pack
Rated voltage (V)	166.4
Rated capacity (Ah)	280

Item	Battery Pack
Configuration	1P52S
Standard charging current (A)	140
Standard discharging current (A)	140
End of charge voltage (Vdc)	187.2
End of discharge voltage (Vdc)	148.2
Dimensions (W*D*H) (mm)	(1160±3) * (810±2) * (245±2)
Weight (kg)	333±5

2.3.2 High-voltage Box

Figure 2-5 High-voltage Box (Front View)

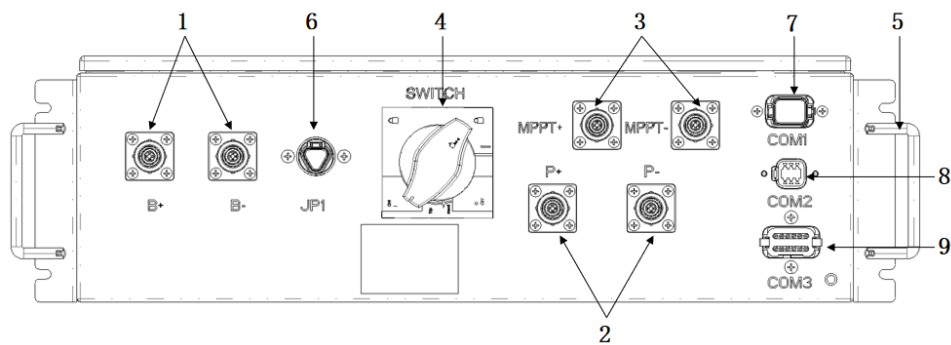

Table 2-5 High-voltage Box (Front View)

No.	Item	Description
1	B+ / B- connectors	Connects to the total positive and total negative terminals of the battery cluster
2	P+ / P- connectors	Connects to the DC side of the PCS
3	MPPT+ / MPPT- connectors	Connects to the high-voltage side of the MPPT
4	Battery circuit switch	Used for opening/closing the DC circuit
5	Handle	Control box handle, used to pull out the control box during maintenance
6	JP1	AC 220V input
7	COM1	24V power cable and BMS communication cable (battery pack communication)
8	COM2	BMS communication cable (PCS communication) and leakage current sensor communication cable
9	COM3	24V power cable and BMS communication cable (EMS communication)

Table 2-6 High-voltage Box Parameters

Item	High-voltage Box
Operating voltage range (Vdc)	741~936
Rated current (A)	140
Rated power (kW)	105
Dimensions (W*D*H) (mm)	(560±2) * (700±2) * (177±2)
Weight (kg)	34.8

2.3.3 Power Conversion Module

PCS

The PCS (Power Conversion System) can control the charging and discharging processes of lithium batteries, enabling bidirectional AC/DC conversion.

Figure 2-6 PCS (Front View)

Figure 2-7 PCS (Back View)

Table 2-7 PCS Description

No.	Item	Description
1	Indicator light	Displays the operating status of the PCS
2	Ethernet port	Communication interface with the EMS
3	Power port	220V AC power input (for commissioning only)
4	Handle	PCS handle, convenient for pulling out the unit
5	AC port	Power connection port on the AC side
6	DC port	Power connection port on the DC side
7	COM communication port	External communication signal port, can be used for module parallel operation

Table 2-8 PCS Parameters

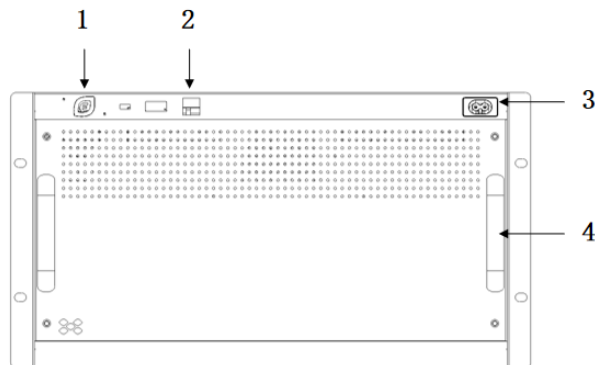
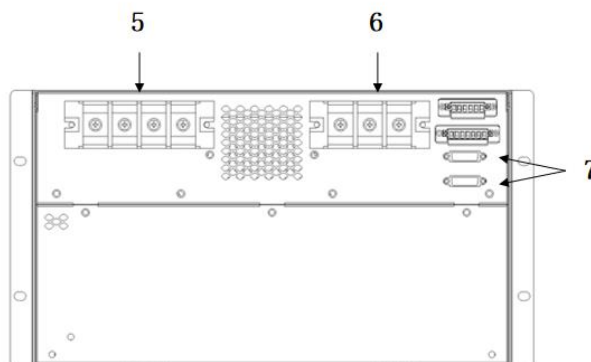
Model		PCS 105kW
DC Side	Operating DC voltage range (Vdc)	650~950
	Maximum DC current (A)	170
AC Side	Rated operating AC voltage (Vac)	230/400
	Rated operating AC frequency (Hz)	50/60
	Rated operating AC current (A)	167
	Rated AC power (kW)	105
General	Dimensions (W*H*D) (mm)	(484±2) * (703±2) * (255±2)
	Weight (kg)	58±2

2.3.4 MPPT

It is used for PV connection.

Figure 2-8 MPPT (Front View)

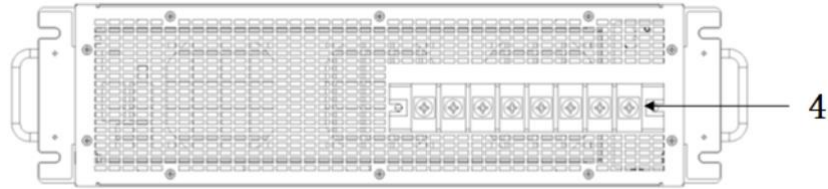
Figure 2-9 MPPT (Back View)

Table 2-9 MPPT Description

No.	Item	Description
1	Indicator light	Displays the operating status of the MPPT
2	Handle	MPPT handle, convenient for pulling out the unit
3	Dust cover	For dust protection
4	Input/Output terminals	Connection terminals for the MPPT's low-voltage and high-voltage sides

Table 2-10 MPPT Parameters

Mode		MPPT 60A
Low voltage side	PV input voltage range (Vdc)	300~670
	Max. input current (A)	200
High voltage side	Operating voltage range (Vdc)	350~1000 (More than 50V Higher Than the Low-Voltage Side)
	Rated current (A)	100
General	Rated Power (kW)	60
	Dimensions (W*D*H) (mm)	(490±2) * (600±2) * (130±2)
	Weight (kg)	30±1

2.3.5 Liquid Cooling Unit

It is a refrigeration product developed specifically for applications such as heat dissipation of energy storage batteries. It is suitable for scenarios where the batteries inside the energy storage cabinet generate significant heat and the internal devices are sensitive to ambient temperature.

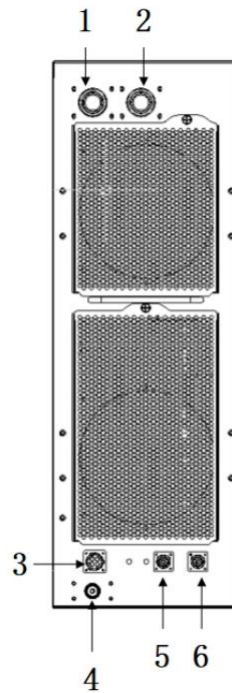
Figure 2-10 Liquid Cooling Unit (Front View)

Table 2-11 Liquid Cooling Unit (Front View)

No.	Item	Description
1	Coolant inlet	For connection to the coolant inlet port
2	Coolant outlet	For connection to the coolant outlet port
3	Power port	For connection to the power supply
4	Filling port	For connection to the coolant refill port
5	Commissioning port	For system commissioning of the liquid cooling unit
6	Communication port	For communication with the EMS

Table 2-12 Liquid Cooling Unit Parameters

Item	Liquid Cooling Unit
Refrigerant	R134a
Refrigerating medium	Pure water or 50% ethylene glycol solution
Maximum power consumption (kW)	3.52
Rated operating voltage (Vac)	220
Maximum operating current (A)	16A
Dimensions (W*D*H) (mm)	(275±2) * (1050±2) * (800±2)
Weight (kg)	85±3

2.3.6 Fire Suppression System

Figure 2-11 Position of the Fire Suppression System

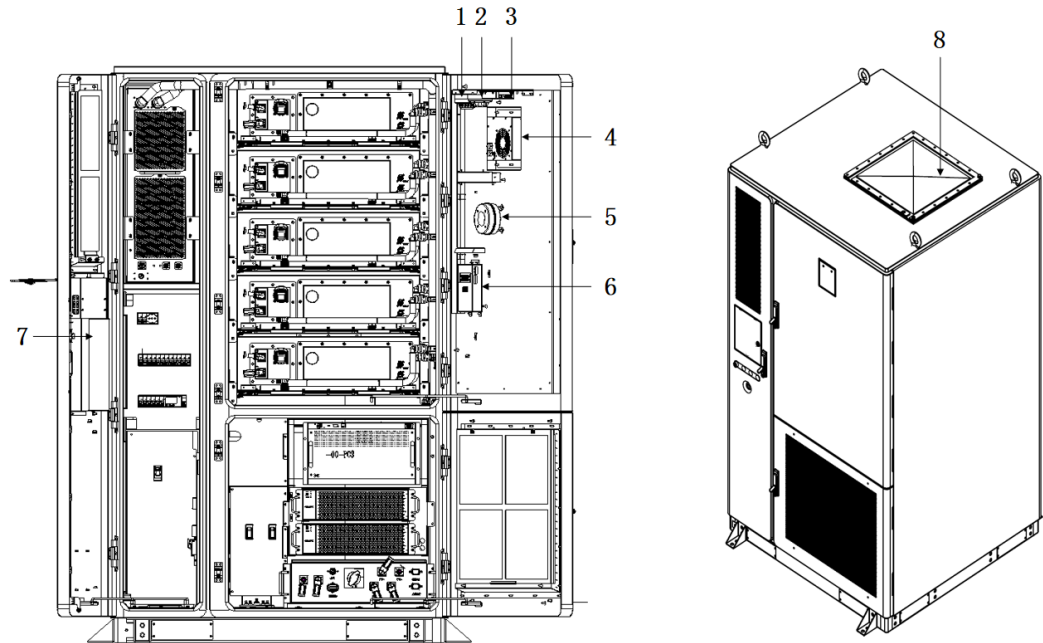

Table 2-13 Position of the Fire Suppression System

No.	Item	Description
1	Smoke detector	Detects the current concentration of smoke in the environment
2	Temperature sensor	Detects the current ambient temperature
3	Combustible gas detector (optional)	Detects the concentration of combustible gases (H ₂ and CO)
4	Exhaust fan	Exhaust combustible gases from the cabinet
5	Aerosol (optional)	Suppresses thermal runaway inside the cabinet
6	Dehumidifier	Dehumidifies the cabinet
7	Buzzer	Indicate system alarm status
8	Deflagration panel (optional)	Relieve explosion pressure

2.3.7 EMS

The Energy Management System (EMS) serves as the central control hub of the energy storage system. It is responsible for real-time monitoring of equipment operating status, coordinating multi-energy collaborative operations, and optimizing energy distribution through intelligent strategies.

Its core capabilities include:

- Real-time acquisition of key parameters such as voltage, current, and State of Charge (SOC) of energy storage devices
- Dynamic management of the charging and discharging process to extend battery life
- Balancing load demand and energy supply
- Seamless integration with external systems via standardized communication protocols, enabling remote control and comprehensive data visualization

The EMS can be used in commercial and industrial energy storage scenarios such as peak-load shifting, self-consumption, dynamic capacity expansion, emergency backup power, and integrated PV-storage systems.

Table 2-14 EMS Description

No.	Item	Description
1	Control functions	Peak-load shifting, self-consumption, dynamic capacity expansion, emergency backup power
2	Communication ports	<ul style="list-style-type: none"> ● 6 Ethernet ports (2 WAN, 4 LAN) ● 8 RS485 ports ● 2 CAN ports ● 16 digital inputs (DI) ● 8 digital outputs (DO)
3	Communication protocols supported	Modbus TCP, IEC 104, MQTT, etc.
4	Dimensions (W*D*H) (mm)	$(210\pm 2) * (165\pm 2) * (44.5\pm 2)$
5	Weight (kg)	2

2.4 Working Principles

2.4.1 Circuit Diagram

Figure 2-12 Power Circuit Electrical Diagram (Pure Storage, with 105kW PCS only)

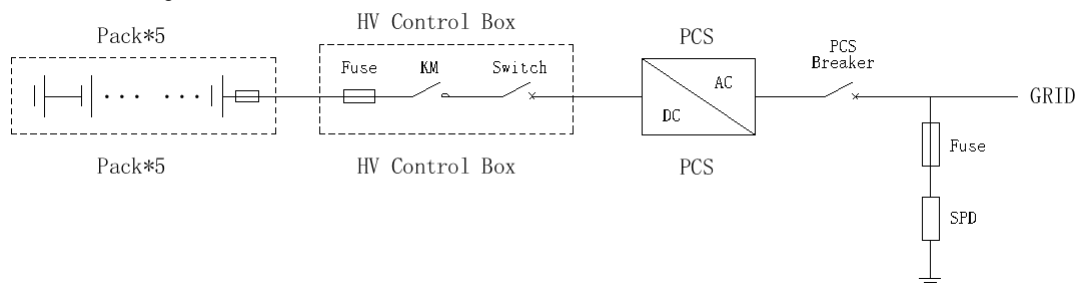

Figure 2-13 Power Circuit Electrical Diagram (PV + ESS, with 105kW PCS and 2*60kW MPPTs)

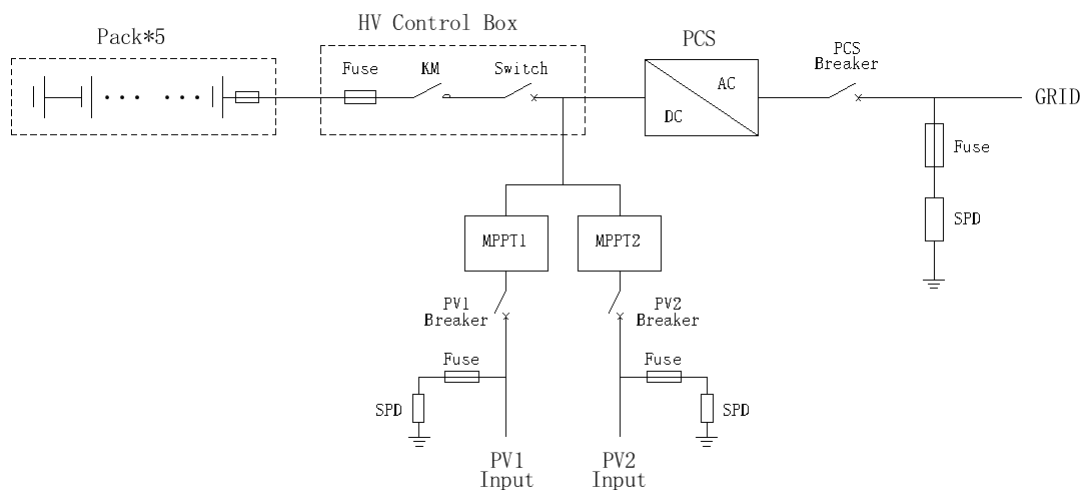
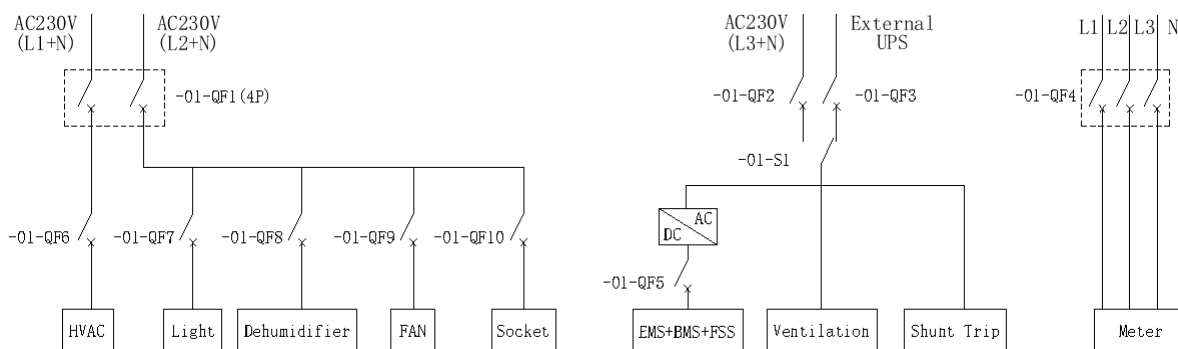

Figure 2-14 AC Auxiliary Power Circuit Electrical Diagram



2.4.2 ESS Status

The PowerHill (233kWh) has three operating states: Running, Alarm, and Fault.

Table 2-15 Operating States

State	Description
Running	The power circuit is operating normally for charge/discharge
Alarm	A general device alarm has been detected; normal operation can resume after the alarm is cleared
Fault	A critical fault related to safety has been detected; the system is shut down

2.5 Networking Applications

Distribution cabinets and external connection cables/lugs are provided by the customer.

2.5.1 On-grid Scenarios

Figure 2-15 Single BESS Pure Storage Electrical Diagram

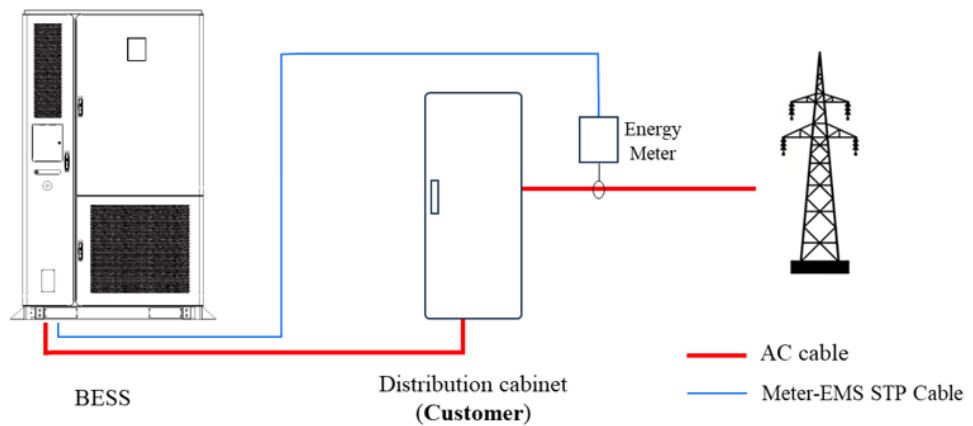

When multiple pure storage BESS units are connected to the grid, they can use an AC Hub for power convergence. The electrical diagram is as follows:

Figure 2-16 Multiple BESS Pure Storage Electrical Diagram

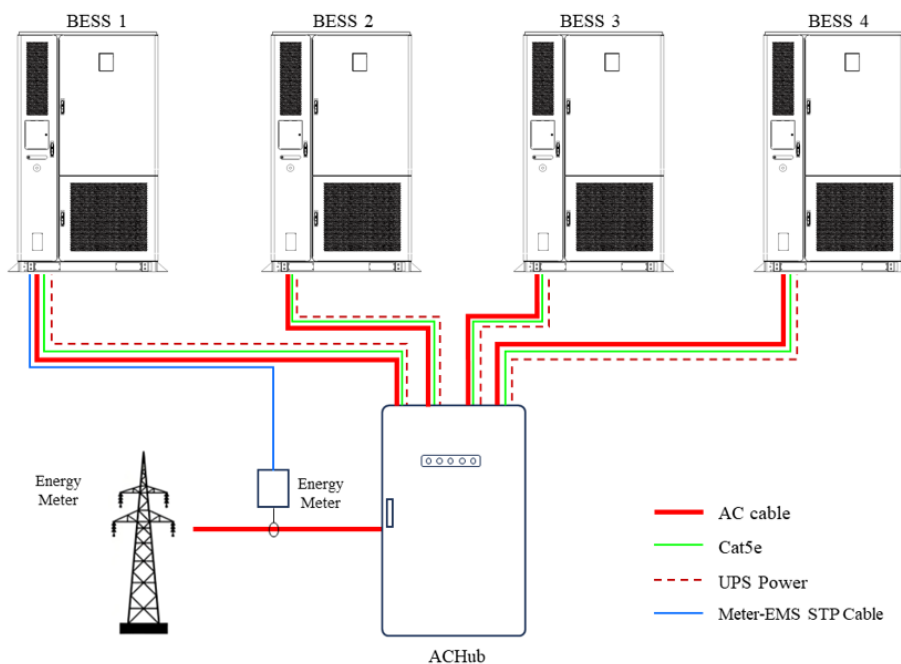

2.5.2 PV-Storage Scenarios

The BESS can optionally be equipped with two 60kW single-channel MPPTs. For individual MPPT input parameters, refer to MPPT section in Chapter 2.3.3. The wiring diagrams are as follows:

Figure 2-17 Electrical Diagram of Single DC-Coupled on-grid system

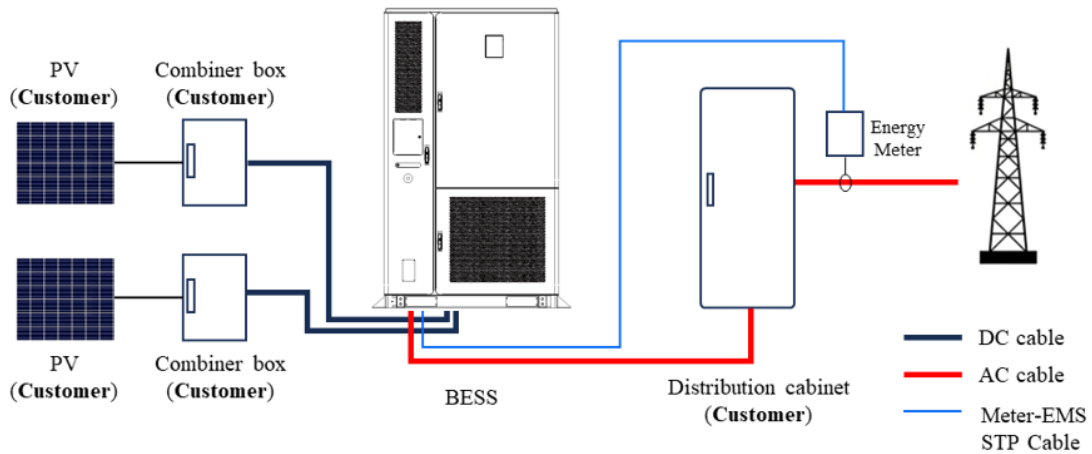
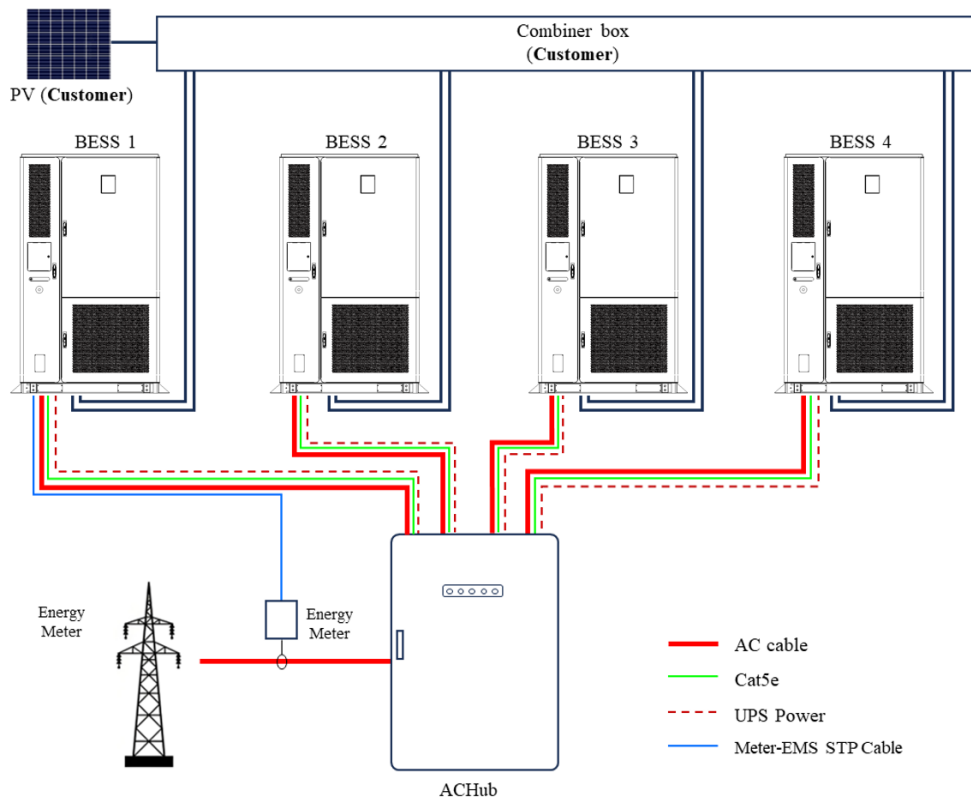
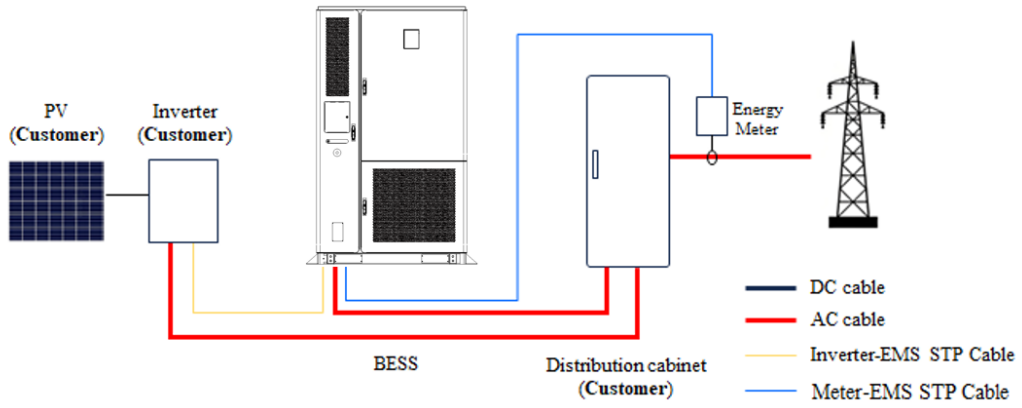

Figure 2-18 Electrical Diagram of Multiple DC-Coupled on-grid systems



If MPPTs are not selected, the system can also be grid-connected using the AC-coupled PV-storage solution shown below:

Figure 2-19 Electrical Diagram of Single AC-Coupled Grid-Connected System



3 Storage Requirements

3.1 ESS Storage and Charging

Environmental Control: The "Golden Range" for Temperature and Humidity

1. Temperature Management

- Energy storage batteries are sensitive to temperature.
- Storage temperature range: -30°C to $+60^{\circ}\text{C}$
- Recommended long-term storage temperature: 20°C to 30°C

2. Humidity Protection

- Humidity should be controlled between 5% and 95% RH (recommended around 45%).
- Excessive humidity may lead to electrolyte leakage or corrosion of metal components.
- The storage environment should be dry and well-ventilated, and exposure to rain must be avoided.
- Desiccants are recommended for long-term storage. In coastal or high-humidity areas, additional dehumidification equipment is required.

Charge Management: SOC "Safe Thresholds"

1. Storage SOC Levels

The State of Charge (SOC) directly affects battery lifespan.

For long-term storage: maintain SOC at $50\% \pm 10\%$, avoid overcharging (SOC > 80%) or deep discharging (SOC < 5%)

2. Periodic Maintenance

Check SOC every 3 months. If SOC < 20%, recharge to 50%.

Maintenance Cycle and Inspection

1. Routine Inspections

- Appearance: Check for deformation, leakage, corrosion
 - Voltage Consistency: For battery packs in series, the voltage difference between cells should be $\leq 8\text{mV}$ (to prevent the “barrel effect”)
 - BMS Status: Ensure there are no alarms, and communication is normal
2. Activation After Long-Term Storage

Before first use: If stored for more than 6 months, slow charge to 50%, then perform 1–2 charge–discharge cycles to restore performance

Safety Measures: From Physical Isolation to Fire Protection

1. Physical Safety

- Storage location: Batteries must be stored separately, not mixed with other equipment.
- Stacking height: Must not exceed the packaging label limits
- Transport precautions: Handle with care, avoid impacts or tilting. Packaging must remain intact
- Abnormal batteries (e.g., swollen or leaking) should be moved to a hazardous materials storage area, at least 3 m away from flammable materials

2. Electrical Isolation

- Power disconnection: Disconnect the battery from load/charger to avoid short circuits
- Insulation: Battery terminals must be covered with protective insulation caps

3. Fire Protection and Monitoring

- Fire equipment: CO₂ extinguishers and fire sand must be available in storage areas
- Water-based extinguishers are prohibited
- Status monitoring: Install temperature/humidity sensors, smoke detectors, and use smart monitoring systems to track battery health in real time.
- If abnormalities (e.g., cell voltage imbalance) are detected, immediate action is required.

3.2 Charging Operation Instructions

Prerequisites

The AC side of PowerHill (233kWh) has been connected to the power grid.

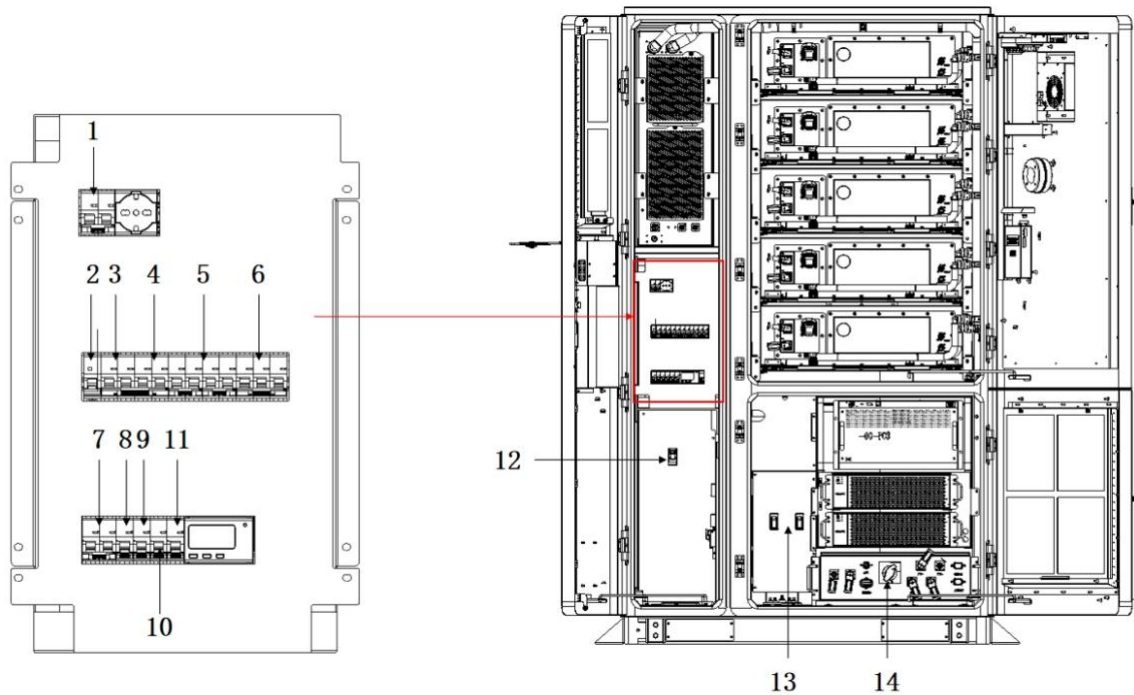
Figure 3-1 Auxiliary Power Distribution Components

Table 3-1 Auxiliary Power Distribution Components

No.	Item	Function
1	-01-QF10	Socket Circuit
2	-01-S1	Switch
3	-01-QF2	Mains Power
4	-01-QF3	External UPS
5	-01-QF1	Auxiliary Power
6	-01-QF4	Voltage Sampling (Meter)
7	-01-QF5	24V
8	-01-QF6	HAVC
9	-01-QF7	Light
10	-01-QF8	Dehumidifier
11	-01-QF9	FAN
12	-00-QF3	PCS Breaker
13	-00-QF1, -00-QF2	PV1 Breaker, PV2 Breaker
14	-02-QF1	PDU Breaker

Procedure and precautions

Step 1: Close "Auxiliary Power", and set "Socket Circuit" handle upwards to ensure grid power supplies the EMS

Step 2: Close "Mains Power" and "24V" to power on EMS, BMS, and fire detectors

Step 3: Sequentially close "Voltage Sampling (Meter)", "HAVC", "Dehumidifier", and "FAN".

Step 4: Close "PDU Breaker"; check on EMS master software that the main control screen shows no alarms

Step 5: Close "PCS Breaker"; this powers the PCS control system (power circuit). Check the EMS master software for any alarms on the PCS interface

Step 6: Close "PV1 Breaker" and "PV2 Breaker" to power on MPPT1 and MPPT2 control systems (indicator lights on). Check EMS master software to confirm no alarms for MPPT1 and MPPT2 (optional, if PV strings are connected)

At this stage, both MPPT and PCS power circuits remain powered off and inactive (power = 0). From the main control interface, close the precharge circuit, then start PCS or MPPT. After confirming no alarms via the EMS interface, set power levels and the equipment will begin operating.

4 Site Requirements

4.1 Site Selection Requirements

NOTICE

NOTICE!

The ESS site selection and fire safety must comply with local laws and regulations.

4.1.1 General Requirements

- The installation level should be above the highest historical water level in the area and at least 300mm above ground level, and the installation location should not be in a low-lying area.
- The energy storage system or energy storage power station must be set up in an environment with no risk of ignition or explosion.
- The site has convenient transportation conditions and reliable fire suppression system equipment.



NOTE!

- The installation, commissioning and operation phases of the energy storage system should satisfy the principle of fire-fighting first: the number of gaseous fire extinguishers configured near each unit should be ≥ 2 , such as Heptafluoropropane, Perfluorohexanone and Carbon Dioxide.
- Meet the necessary site area in the near future, and should leave room for expansion according to the needs of the whole life cycle.

- The energy storage system should be installed at a location greater than 30m from third-party wireless communication facilities.
- Select a well-ventilated site.
- Site location should avoid scenarios that are not recommended by industry standards and regulations, including but not limited to the following lots, areas, and places:
 - Areas with strong vibration, strong noise sources and strong electromagnetic field interference.
 - Sites that produce or have dust, fumes, noxious gases, corrosive gases, etc.
 - Places where corrosive, flammable and explosive substances are produced or stored.
 - Places with existing underground facilities.
 - Places with poor geology such as rubberized soil, weak soil, etc., and ground that is prone to water accumulation and subsidence.
 - Underneath cisterns, water features, and water intake houses.
- If it is unavoidable to set up in a place where water may accumulate, water-blocking and drainage facilities or measures to raise the ground level should be installed.
- Cable trenches should not be used as drainage paths, and cable routing openings (e.g., holes where cables run through partition walls and floor slabs) should be sealed with fire-resistant blocking.
- Earthquake faults and seismic zones with an intensity of defense higher than 9 degrees.
- Lots with mudslides, landslides, quicksand, caves and other direct hazards.
- Within the boundary of mining trap (misalignment) area.
- Within the blasting hazard areas.
- Areas that may be flooded if a dam or dike breaks.
- Important sanitary protection areas for water supply sources.
- Historical relics and monuments protection zones.
- Personnel-intensive places, high-rise buildings, and underground buildings.

-
- Intersections of urban arterial roads and busy traffic sections.
-

4.1.2 Flood Prevention and Flood Control Requirements

- Large electrochemical energy storage system (power $\geq 100\text{MW}$) station area site design elevation should be higher than the flood water level with a frequency of 1% or the highest historical waterlogging level.
- The design elevation of the station area for small and medium-sized electrochemical energy storage systems (power $< 100\text{MW}$) shall be higher than the flood level with a frequency of 2% or the highest historical flood level.
- When the site design elevation of the station area cannot meet the above requirements, another site should be selected, or different flood prevention and flood control measures should be taken for different situations.
- For energy storage stations along rivers, streams, lakes and seas that are affected by wind and waves, the elevation of the flood prevention facilities should take into account a wind and wave height with a frequency of 2% and a safety over-height of 0.5m.
- When there is a large catchment of water at the periphery of the base that converges into or crosses the base, it is appropriate to set up side ditches or drainage (interception) ditches to carry out surface drainage in an organized manner.

4.1.3 Outdoor Requirements

General requirements for the siting of outdoor energy storage systems are as follows:

- The energy storage system or energy storage plant installation site and the surrounding 3m area shall be free of vegetation and flammable plants to prevent wildfires caused by high summer temperatures from causing fires in the energy storage system. (Exemption: single specimens of trees, shrubs, or cultivated ground cover that do not readily constitute a passing fire, such as green grass, ivy, succulents, or similar plants used as ground cover, shall be exempt.)
- The safe distance between the energy storage system and the building shall comply with local fire codes or standards.

Energy storage systems located outdoors shall be separated from boundaries, public roads, buildings, flammable materials, hazardous materials, high stockpiles, parking spaces, and other hazards not related to the grid infrastructure by a minimum of 10 feet (3.048m).

The distance between the energy storage system and the production building can be reduced to 0.914m when one of the following conditions is met, while space requirements for equipment transportation, installation, and maintenance need to be considered.

The energy storage system has a 1h fire-resistant independent firewall, and the length and height of the firewall should exceed the outer contour of the energy storage system by 1.5m each.

The walls in the vicinity of the energy storage system are provided with non-combustible exterior walls with no openings or combustible exterior finishes, and the exterior walls have a 2h fire resistance rating in accordance with ASTM E119 or UL 263.

The distance between the exhaust of the energy storage system and heating, ventilation, and air conditioning intakes, windows, doors, loading platforms, and sources of ignition of other buildings or facilities should be >4.6m.

The energy storage system will be corroded if it is installed in salt-affected or polluted areas, do not install the energy storage system in salt-affected or polluted areas. The energy storage system can be used in the following or better environments:

Outdoor environments greater than 10km from the coast. The use of the energy storage system is not recommended when the distance from the coast is 2km to 10km (if it is necessary to use it, please confirm with your dealer or our engineers). Outdoor deployment is not allowed when the distance from the coast is less than 2km, and indoor deployment should be performed according to indoor requirements.

Distance from heavy pollution sources such as smelters, coal mines, thermal power plants, etc. is more than 5000m.

Distance to medium pollution sources such as chemical, rubber, electroplating, etc. is greater than 3000m.



NOTE!

When the safety spacing of the selected site cannot meet the requirements of the relevant standards, it is recommended to select a new site.

Anti-trespassing fence:

It is recommended that the area of energy storage equipment be isolated and protected by solid walls or fences with door locks, and the height of the fences should be >2.2 meters, and the firewall can replace part or all of the fence, which can be considered by the designer.

4.2 Space Requirements

Figure 4-1 Space Requirements for 1 ESS

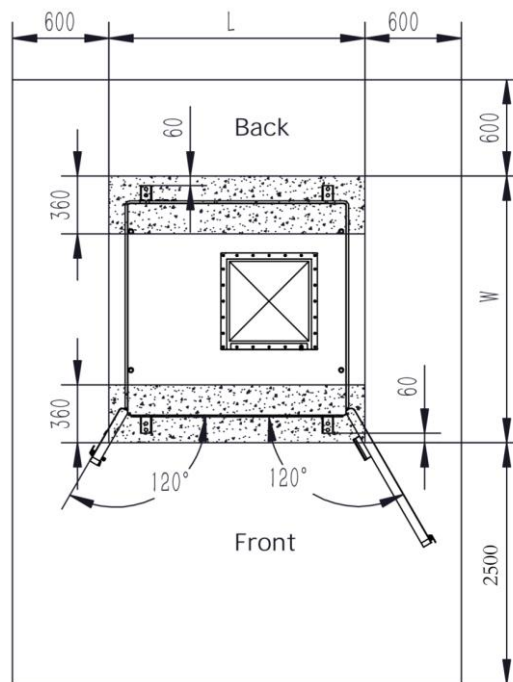

Table 4-1 Minimum Hardening Area for 1 ESS

Category	Parameter
Minimum Hardening Area	$L \geq 1590\text{mm}$, $W \geq 1660\text{mm}$

Figure 4-2 Space Requirements for 2 ESS

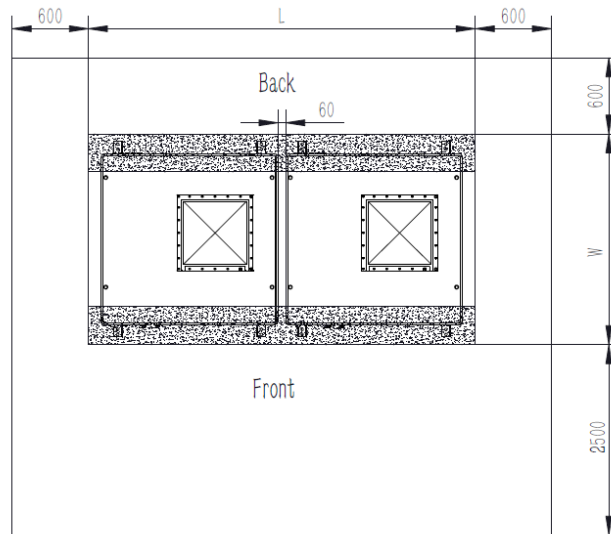

Table 4-2 Minimum Hardening Area for 2 ESS

Category	Parameter
Minimum Hardening Area	$L \geq 3040\text{mm}$, $W \geq 1660\text{mm}$

Figure 4-3 Space Requirements for 2 ESS (Back-to-back Installation)

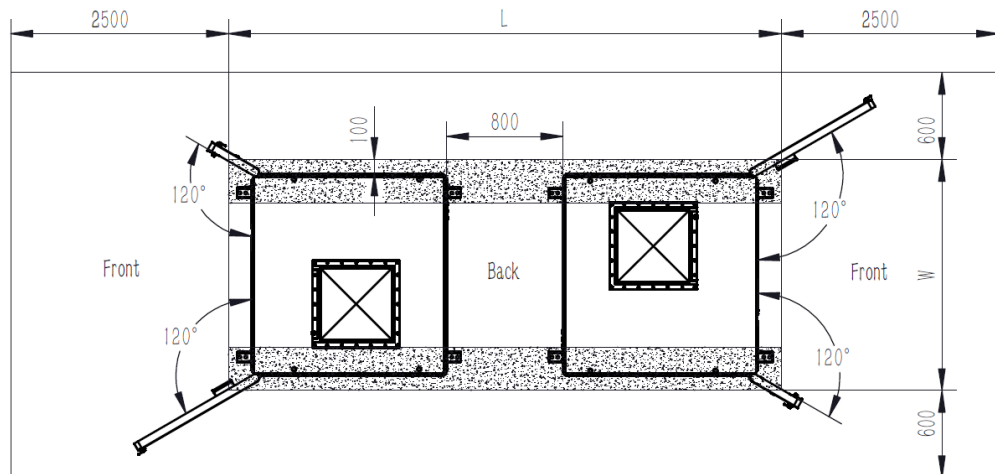
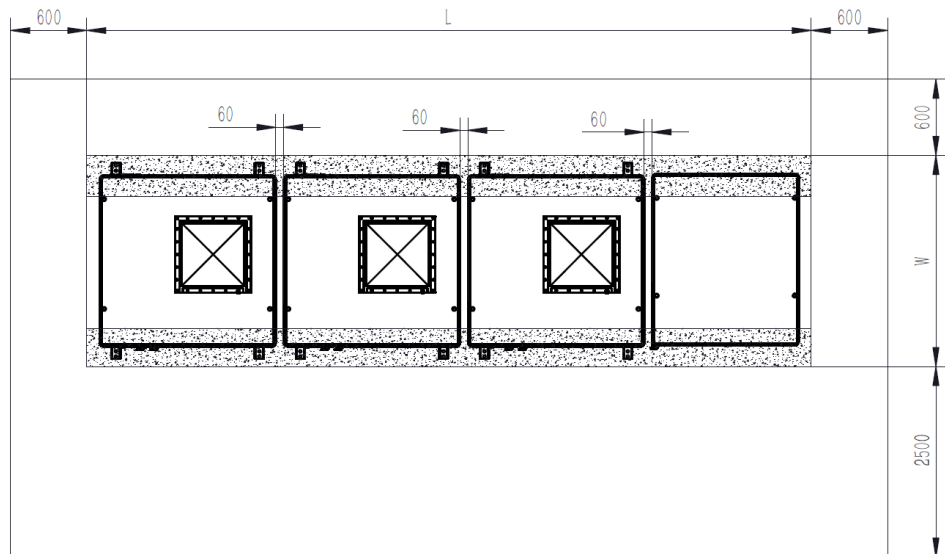

Table 4-3 Minimum Hardening Area for 2 ESS (Back-to-back Installation)

Category	Parameter
Minimum Hardening Area	$L \geq 3810\text{mm}$, $W \geq 1590\text{mm}$

Figure 4-4 Space Requirements for 3 ESS + PCC

Table 4-4 Minimum Hardening Area for 3 ESS + PCC

Category	Parameter
Minimum Hardening Area	$L \geq 5940\text{mm}$, $W \geq 1660\text{mm}$

4.3 Foundation Requirements

Requirements of the foundation design scheme:

- The energy storage system must be installed on concrete or other non-combustible surfaces, and must ensure that the installation plane is level, firm, and flat, with sufficient bearing capacity, and depressions or tilts are prohibited.
- Equipment foundations are configured according to the total weight of the equipment, and need to be reviewed when the load-bearing capacity of the foundation is not satisfied.
- The bottom of the pit of the equipment foundation must be compacted and filled.
- Equipment foundations should not be disturbed by soaking water after excavation, and should continue to be excavated and refilled if disturbed by soaking water.
- The leveling error of the contact surface between the equipment foundation and the cabinet is $\leq 3\text{mm}$.
- The foundation must be higher than the highest water level in local history and at least 100mm above the horizontal ground.

- Drainage facilities shall be constructed in accordance with the local geology and municipal drainage requirements to ensure that no water accumulates at the foundation of the equipment.
- The foundation should be constructed to meet the local historical maximum rainfall drainage requirements, and the discharged water should be disposed of in accordance with local laws and regulations.
- When constructing the equipment foundation, consider the cable outlet of the energy storage system, and reserve a trench or a hole for the cable.
- The holes reserved for the equipment foundation and the inlet holes at the bottom of the equipment should be blocked.
- The foundation drawing cannot be regarded as the final construction drawing and is for reference only, please contact our product manager for details. Users should review the foundation design parameters of the energy storage system according to the installation environment, ground bearing capacity, geological conditions and seismic requirements of the project site.

Figure 4-5 Foundation Diagram

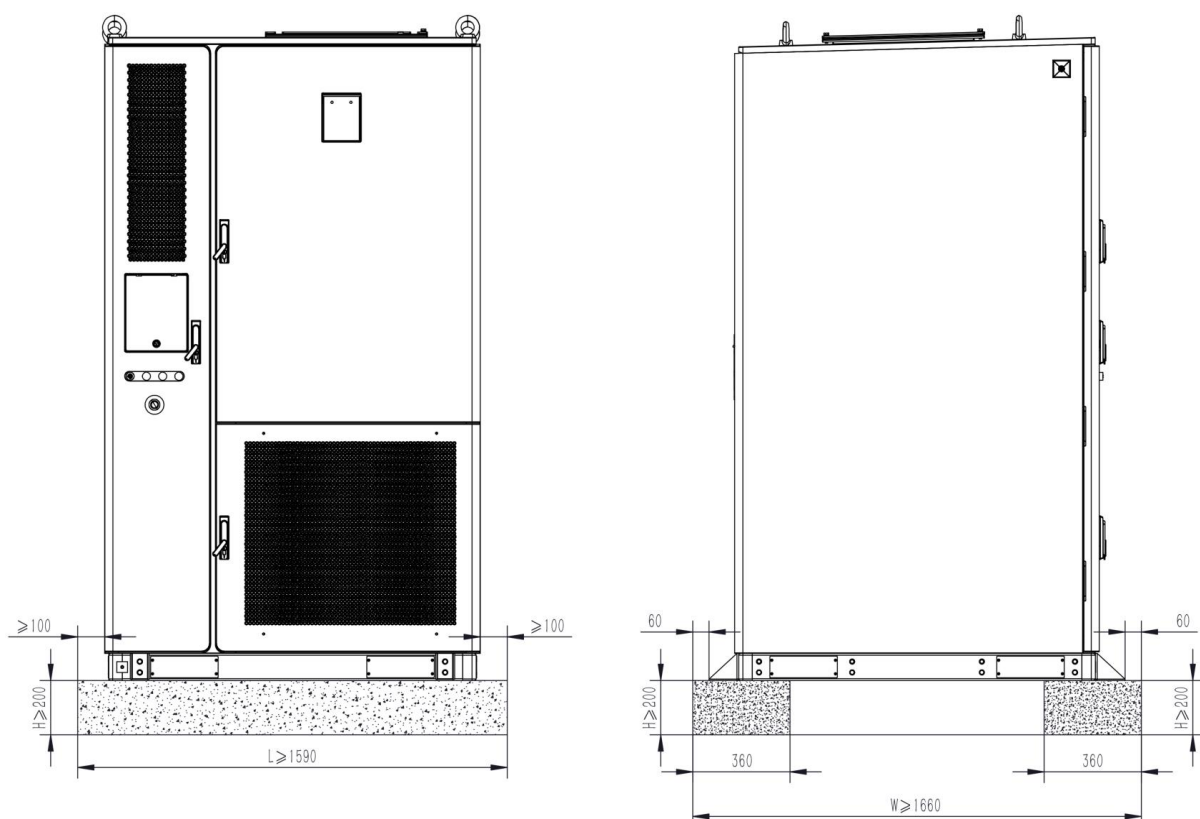

NOTE!

L indicates the width of the mounting surface of a single cabinet, W indicates the depth of the mounting surface of a single cabinet, the site can be prepared in advance of the steel shims, the cabinet mounting base levelling.

Table 4-5 Foundation Diagram

Category	Parameter
Minimum Hardening Area	$L \geq 1590 \text{ mm}$, $W \geq 1660 \text{ mm}$
Installation Foundation Height	$H \geq 200 \text{ mm}$ (above the highest historical flood level)
Install Foundation Loading Capacity	Loading Capacity $> 3 \text{ T} / \text{m}^2$
Service Life of the Foundation	$\geq 20 \text{ years}$
Leveling of the Foundation	$3 \text{ mm}/\text{m}^2$

5 Unpacking and Acceptance

Precautions & Inspection Items

The integrated energy storage system has been thoroughly inspected and securely packaged by our staff prior to shipment. However, collisions or damage may still occur during transportation. Upon receipt of the equipment, it is essential to inspect the integrity and condition of the shipment. At a minimum, the following items should be carefully verified:

- Check all delivered components against the "Scope of Supply" to ensure completeness.
- Confirm that the received integrated energy storage system and internal devices match the model and specifications of your original order.
- Carefully inspect the system and its internal devices for any damage that may have occurred during transportation.

If any issues are found or if you have any concerns during the inspection, please contact the carrier or Dunext immediately.



WARNING!

Only integrated energy storage systems that are complete and undamaged may be installed and put into trial operation!
Before beginning installation, please ensure the following:

- The energy storage system itself is intact and free of any damage.
- All internal devices within the system is in good condition and undamaged.

6 Product Installation

6.1 Preparation Before Installation





6.1.1 Preparing Tools







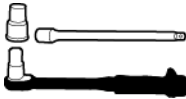

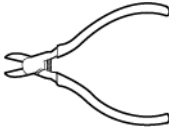

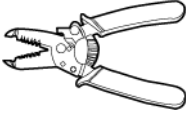

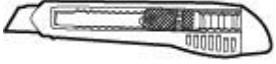
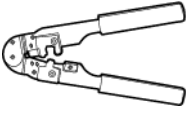
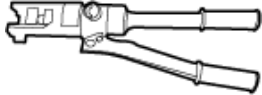

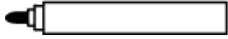
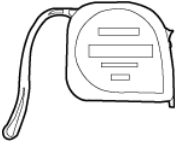

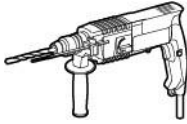
NOTE!

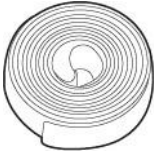
- The tools shown in the picture are for reference only, please refer to the physical object.
- Due to the different site conditions, this tool list cannot completely list a few tools that may be used, site installers and users please prepare the unlisted tools according to the actual situation.

Table 6-1 Installation Tools

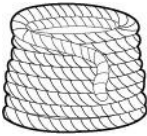
  <p>Phillips Insulated Torque Screwdriver</p>	 <p>Insulated Torque Socket Wrench (Including extension bar)</p> <ul style="list-style-type: none"> • Socket specifications: 7mm~19mm • Socket depth ≥ 32mm • Sleeve interface and torque • Matching with torque wrench • Torque range: 1.2N- m~45N-m 	  <p>Slotted Insulated Torque Screwdriver</p>	 <p>Diagonal Nose Pliers</p>
--	---	--	---

 Wire Strippers Pliers	 Wire Cutting Pliers	 Rubber Hammer	 Knife
 Crystal Head Crimping Pliers	 Hydraulic Pliers	 Multi-meter DC Voltage Range $\geq 1500V$ DC	 Marking Pen
 Steel Tape Measure	 Horizontal Ruler	 Vacuum Cleaner	 Impact Drill
 Impact Drill $\Phi 16mm$	 Heat Shrink Tubing	 Hot Air Gun	 Wire Tie
 Insulation Ladder	 Crane	 Lanyard Rope Rope length $\geq 1,845mm \times 4$	 Electric Forklift









	-	-	-
Manual Forklift			

Table 6-2 Personal Protection Tools

			
Insulated Gloves	Protective Gloves	Goggles	Dust Mask
			
Insulated Shoes	Reflective Undershirt	Safety Helmet	Safety Belt

6.1.2 Inspection Before Installation

Package Inspection

Before unpacking the outer packaging of the PowerHill (233kWh), check the package for visible damage such as holes, cracks, or other signs of possible internal damage, and verify the product model number. If there are any package anomalies or if the product model number does not match, do not unpack it and contact your dealer as soon as possible.



NOTE!

It is recommended to remove the outer packaging within 24 hours prior to equipment installation.

 WARNING!	<p>When removing the outer packaging, please take precautions for overhead operation.</p>
--	---

Delivery Parts Inspection



After unpacking the device, please check that the delivery parts are complete and that there is no visible external damage. If any items are missing or there is any damage, please contact your dealer.

 NOTE!	<p>For the number of delivery parts dispatched with the box, please refer to the Packing List inside the package. Please keep the key properly after use. After opening the package, please check the delivery parts and quantity of the package according to the Packing List, if there are any missing parts, please contact your dealer as soon as possible.</p>
---	---

6.2 ESS Installation

Transportation Requirements

All devices inside the outdoor ESS are pre-installed and securely fastened before delivery. The ESS should be transported as a whole using lifting equipment.

 WARNING!	<ul style="list-style-type: none"> ● During the entire loading, unloading, and transportation process, local outdoor cabinet safety regulations must be followed. ● All machinery used for handling the cabinet must be well-maintained. ● All personnel involved in loading, unloading, and securing must be properly trained, especially in safety protocols.
 CAUTION!	<p>Keep the mechanical parameters of the outdoor battery cabinet in mind throughout transportation.</p> <p>Conditions for Moving the Cabinet:</p> <ul style="list-style-type: none"> ● All cabinet doors must be locked. ● Choose an appropriate crane or lifting equipment according to the site conditions. Ensure it has sufficient load-bearing capacity, boom length, and swing radius. ● Additional traction equipment may be required if moving on slopes. ● Remove all actual or potential obstacles in the transport path, such as trees or cables.

- Preferably conduct transport operations in good weather.
- Warning signs or barriers must be installed to prevent unauthorized personnel from entering the lifting area.

Forklift Transport

If the installation site is flat, a forklift can be used. The cabinet base has fork holes for this purpose. Remove the protective plates covering the fork holes before use. Reinstall them after installation is complete.

Forklift Transport Requirements:

- The forklift should have a load capacity of at least 4 t.
- Forks should be at least 1500 mm long and inserted into the designated fork holes on the cabinet base (see figure below for red-circled locations).
- Transport and placement should be slow and stable. Test runs are recommended.
- The cabinet must only be placed on a stable, level surface that is well-drained and obstacle-free.
- The cabinet should be secured using the four corner mounting brackets.

Figure 6-1 Fork Holes

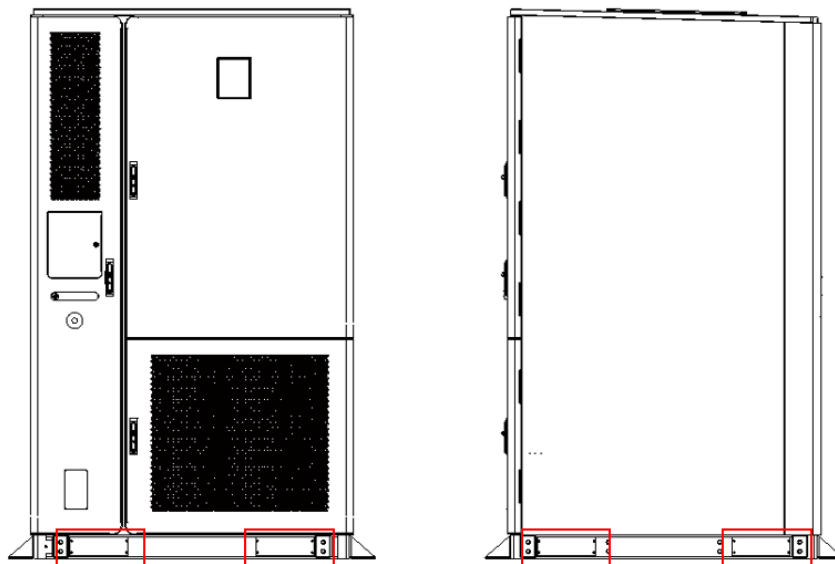

Figure 6-2 Forklift Requirements

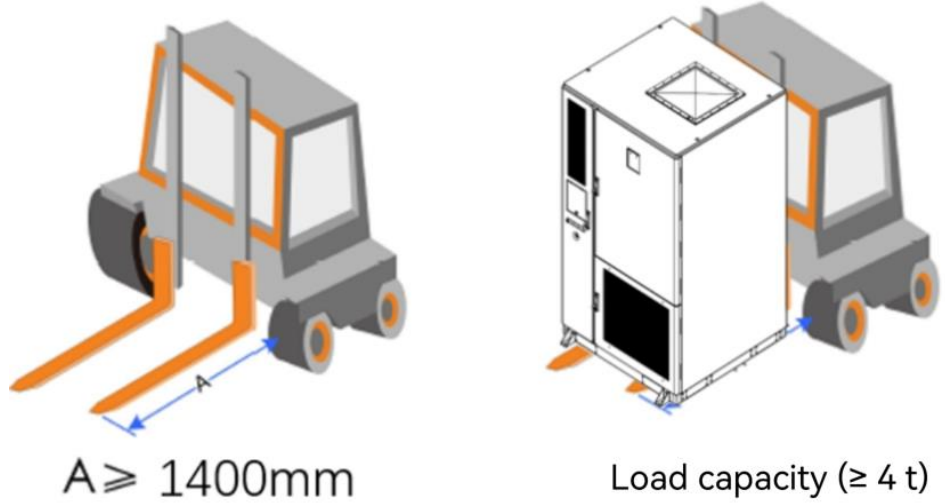
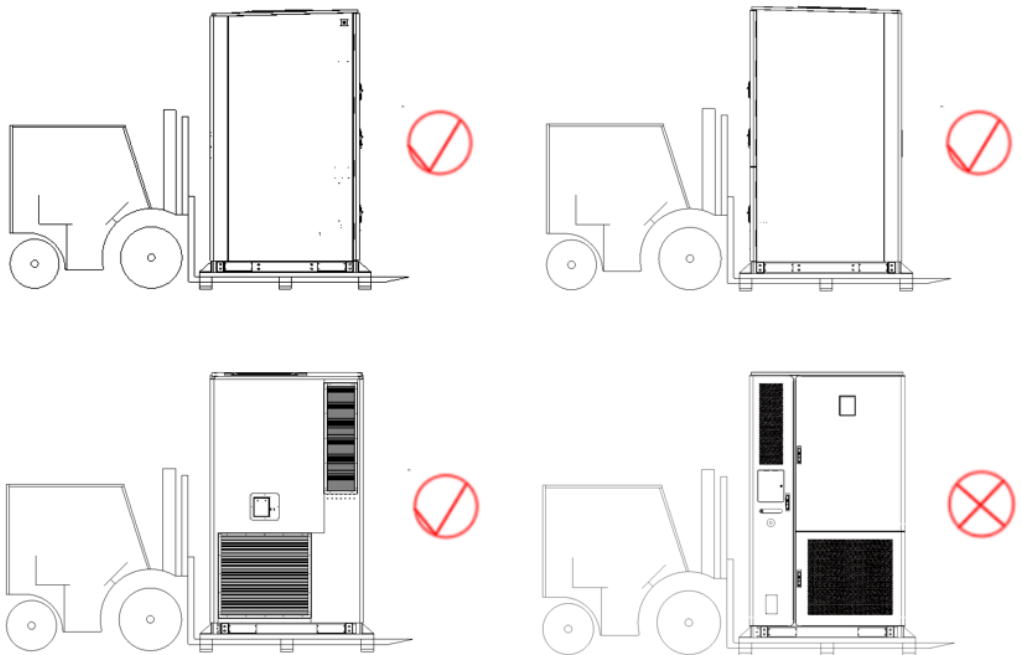

Figure 6-3 Forklift Transport Requirements



Note: the figure above is for reference only.

Crane Transport

Lifting Precautions



WARNING!

- Operate the crane strictly in accordance with its safety operation manual.
- No personnel are allowed within a 5-10 m radius of the operating area, especially under the boom or lifted equipment.
- Lifting must stop in extreme weather such as heavy rain, fog, or strong winds.

Lifting Requirements:

- Ensure on-site safety during the entire lifting process.
- A professional must supervise the entire lifting and installation process.
- The lifting straps must be strong enough to support the cabinet weight.
- Ensure all strap connections are secure and that all segments are of equal length.
- Adjust strap lengths as necessary according to site conditions.
- The cabinet must be lifted smoothly and without tilting.
- Use all four lifting eyes on the cabinet.
- Take all necessary auxiliary measures to ensure safe and smooth lifting.

The figure below illustrates the crane's working range. The inner dashed circle indicates the crane's operation area; no personnel should be inside the outer solid circle during operation.

Figure 6-4 Crane Working Range

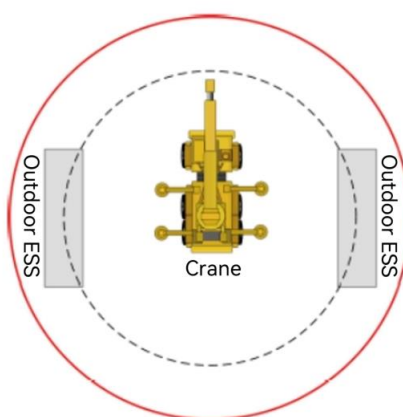

Fasten the Lifting Eyes

Top Lifting Eye Installation: The lifting eyes are shipped as accessories and must be installed before lifting.

Installation Requirements:

- Check the lifting eye specifications: M24, Grade 12.9 carbon steel, free of cracks, deformation, or thread damage. The installation hole must be perpendicular to the surface and deep enough for the entire thread.
- Recommended tightening torque: 1100 N·m (tighten in steps: initial 550 N·m → second 880 N·m → final 1100 N·m), with 5-minute intervals to release stress. Mark the bolt and contact surface after final tightening.
- Use a calibrated torque wrench (±3% accuracy) and record torque values.
- Apply thread-locking adhesive to the thread before installation to prevent loosening.
- The lifting eye should be perpendicular to the lifting direction to avoid side forces (see figure below).

Figure 6-5 Lifting Eye Direction

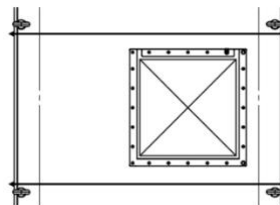



- Post-installation Inspection: Ensure there are no cracks, deformation, or thread damage, and that the anti-loosening marks align.

Lifting straps with hooks or U-hooks can be used.

The lifting device must be correctly connected to the cabinet.

Table 6-3 Lifting Position and Precautions

Lifting Position	Lifting Eye	U-type Lifting Eye
Image		
Remarks	Hooks must be placed from inside to outside (not vice versa)	Horizontal pins must be tightened.



WARNING!

- Never lift the cabinet from the fork holes.
- Always comply with the safety standards and regulations of the destination country/region.
- The company assumes no responsibility for personal injury or property loss resulting from violations of these

requirements or other safety standards.

Lifting Procedure:

- Always lift the cabinet vertically. Dragging on the ground or across other cabinets is strictly prohibited.
- After lifting the cabinet 300 mm off the ground, pause and inspect the connections before proceeding.
- Place the cabinet down gently and ensure it lands stably. Do not swing the straps to position the cabinet outside the vertical drop area.
- The cabinet should be placed on a solid, flat, well-drained surface free from obstructions or protrusions. Secure the cabinet using its four corner brackets.

If vertical lifting is not possible due to site limitations, lift from the four lifting eyes using angled force as required.

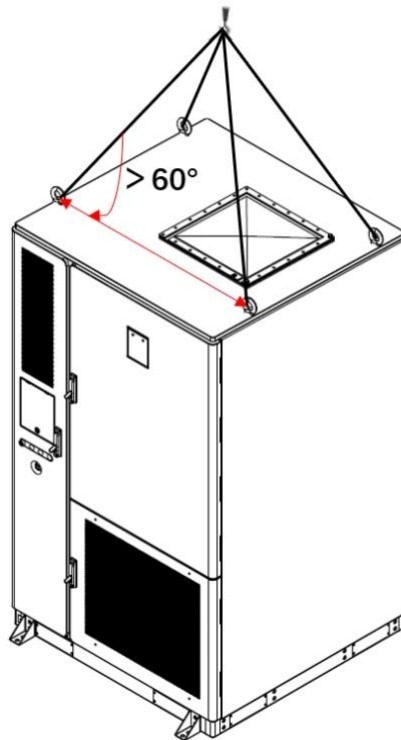
Figure 6-6 Lifting Angle

Note: The figure above is for reference only; please refer to the actual delivered equipment.

Fixed Installation

After confirming that the foundation meets requirements and is dry, solid, and level, lift and place the cabinet in the designated position.

Use anchor bolts to fasten the L-shaped steel brackets at the cabinet base to the foundation. Refer to the figure below for the bracket locations.

Figure 6-7 L-shaped Steel Bracket Location (Top View)

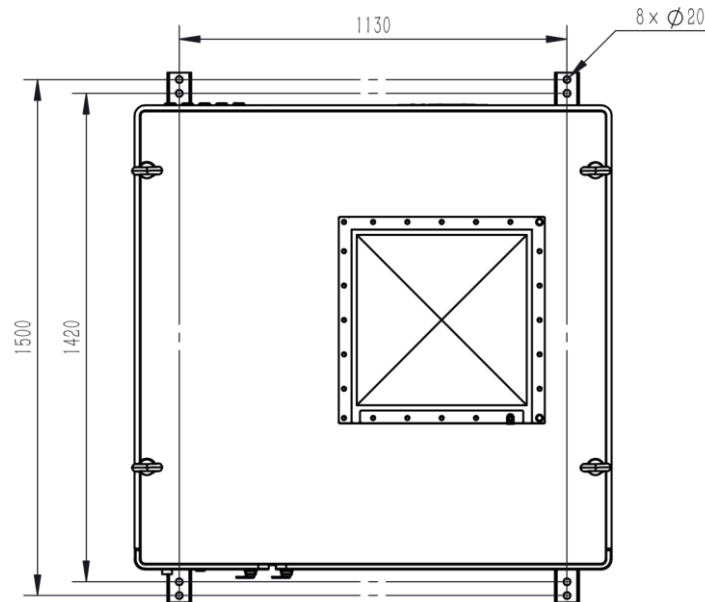

Each L-shaped steel bracket has two oblong holes (diameter: 20 mm). Use M16 bolts.

Figure 6-8 L-shaped Steel Bracket Fastening

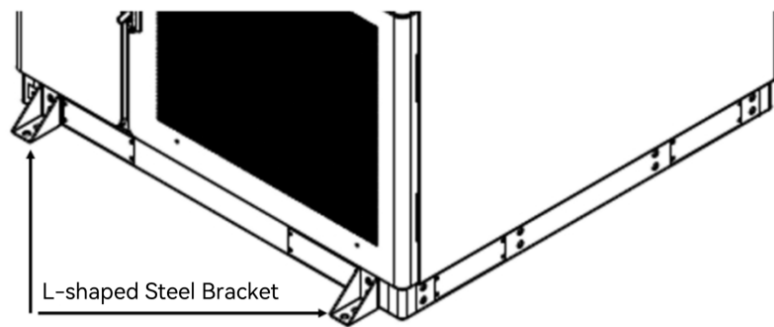

After fastening, apply rust protection (e.g., rustproof paint) to the brackets.

7 Cables Installation

7.1 Cable Preparation

Product Model	Rated Current (A)	Cable Type	Cable Material	Cross-section Area (mm ²)	Terminal	Remarks
PowerHill-P105-233 kWh	152A	L1, L2, L3	Copper	50	SC 50-8	/
			Aluminum	70	SC 70-8	/
		Neutral/ Ground	Copper	25	SC 25-8	If there are big single-phase loads, and the three-phase load imbalance are huge, it is recommended that the cross-section area of the Neutral Cable be the same as that of L1, L2, L3.
			Aluminum	35	SC 35-8	
	/	PCS Parallel Cable	CAN: Shielded Twisted Pair Cable	0.5	/	Characteristic Impedance: 120Ω
			Other: Shielded Cable	0.5	/	/
PCS-STC Communication Cable			CAN: Shielded Twisted Pair Cable	0.5	/	Characteristic Impedance: 120Ω

Product Model	Rated Current (A)	Cable Type	Cable Material	Cross-section Area (mm ²)	Terminal	Remarks	
			Other: Shielded Cable	0.5	/	/	
		RS485	Shielded Twisted Pair Cable	/	/	Characteristic Impedance: 120Ω	
		Network Cable	CAT 5E Network Cable	/	RJ45 connector	/	
		UPS Power Cable	Copper	1.5	/	/	
PowerHill-P105M120-233kWh	152A	L1, L2, L3	Copper	50	SC 50-8	/	
			Aluminum	70	SC 70-8	/	
		Neutral/ Grounding	Copper	25	SC 25-8	If there are big single-phase loads, and the three-phase load imbalance are huge, it is recommended that the cross-section area of the Neutral Cable be the same as that of L1, L2, L3.	
			Aluminum	35	SC 35-8		
	≤ 200A	PV	Copper	50	SC 50-8	Voltage ≤670Vdc	
			Aluminum	70	SC 70-8		
	/		PCS Parallel Cable	CAN: Shielded Twisted Pair Cable	0.5	/	Characteristic Impedance: 120Ω
				Other: Shielded Cable	0.5	/	/
			PCS-STC Communication Cable	CAN: Shielded Twisted Pair Cable	0.5	/	Characteristic Impedance: 120Ω
				Other: Shielded Cable	0.5	/	/

Product Model	Rated Current (A)	Cable Type	Cable Material	Cross-section Area (mm ²)	Terminal	Remarks
		RS485	Shielded Twisted Pair Cable	/	/	Characteristic Impedance: 120Ω
		Network Cable	CAT 5E Outdoor Shielded Network Cable	/	/	Internal resistance ≤ 1.5Ω/10m, with RJ45 connector

Cable selection shall comply with local cable standards. Factors affecting cable selection include: current-carrying capacity, cable type, installation method, ambient temperature, and maximum allowable line losses.

Routing Recommendation:

- Cables should enter the cabinet from the bottom via cable trenches.
- The cabinet base is equipped with removable panels for easy cable threading during installation.

Figure 7-1 Cable Position

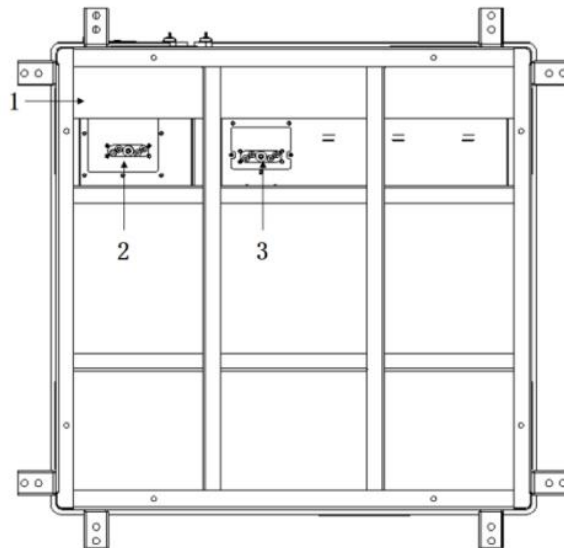

Table 7-1 Cable Position

No.	Cable	Remarks
1	PCS-STC Communication Cable PCS Parallel Cable UPS Power Cable 485 Communication Cable	After cable installation, all openings must be sealed with fire clay to prevent pest entry.

No.	Cable	Remarks
2	AC Cable (Grid)	
3	DC Cable (PV)	

7.2 Grounding Cable Installation

System Connection Method: 3W+N+PE

Figure 7-2 Grounding Point Location

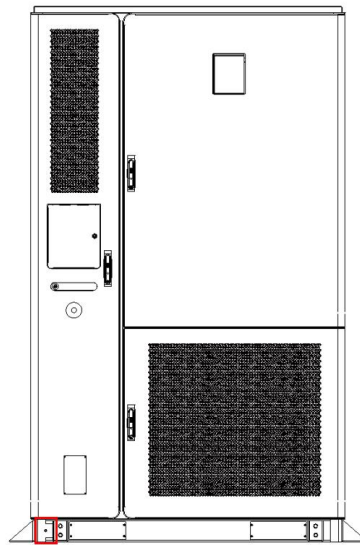

Grounding Points: Designed on the front-left and rear-right of the system chassis near the leveling feet.

BESS Grounding: A repeated grounding connection is required for the BESS in the power distribution network, with a grounding impedance $\leq 4\Omega$.

7.3 Reserved Port Wiring

The pin definitions and cable requirements for the ESS's reserved ports are listed in the table below. Refer to the port silkscreen labels and wiring figure for details.

Table 7-2 Reserved Port Description

Port	Terminal	Recommended Cable	Function	Wiring Scenario
RJ45 Port	WAN1	Network Cable (Cat5e)	For inter-EMS information exchange during multi-cabinet parallel operation	Parallel multiple BESS with AC Hub/PCC present
	WAN2	Network Cable	Internet access or	/

Port	Terminal	Recommended Cable	Function	Wiring Scenario
		(Cat5e)	northbound communication for EMS. (Requires a network switch for simultaneous use.)	
	Switch1 /IO	Network Cable (Cat5e)	For communication between EMS and switch (AC Hub or PCC)	Applicable for multiple parallel cabinets with AC Hub/PCC
-06-X41	1, 2	CAN: Shielded Twisted Pair Cable	During multi-cabinet operation: Communication between PCS in current cabinet and PCS in previous cabinet, or communication between PCS in current cabinet and STS in the PCC	
	3, 4, 5	Shielded Cable		
	6, 7	CAN: Shielded Twisted Pair Cable	During multi-cabinet operation: Communication between PCS in current cabinet and PCS in next cabinet	
	8, 9, 10	Shielded Cable		
-06-X42	1, 2	CAN: Shielded Twisted Pair Cable	Reserved BMS debugging port	For debugging purposes only - no wiring required during field installation
	3, 4	CAN: Shielded Twisted Pair Cable	Reserved CAN communication ports for MPPT1	
	5, 6	CAN: Shielded Twisted Pair Cable	Reserved CAN communication ports for MPPT2	
-06-X43	1, 2	RS485: Shielded Twisted Pair Cable	RS-485 Communication ports between EMS and external inverter	PV-storage AC coupling
	3, 4	RS485: Shielded Twisted Pair Cable	RS-485 Communication ports between EMS, STS, PCC meter and generator	When an external PCC cabinet or generator is configured
	5, 6	RS485: Shielded Twisted Pair Cable	RS-485 Communication ports between EMS and grid meter	When a utility metering point is required/installed
-06-X31	1, 2	220V Power cable, Conductor cross-sectional area $\geq 1.5 \text{ mm}^2$	External UPS power supply port reserved for BESS	Required when external UPS power supply is needed

Figure 7-3 Reserved Port Silkscreen and Wiring

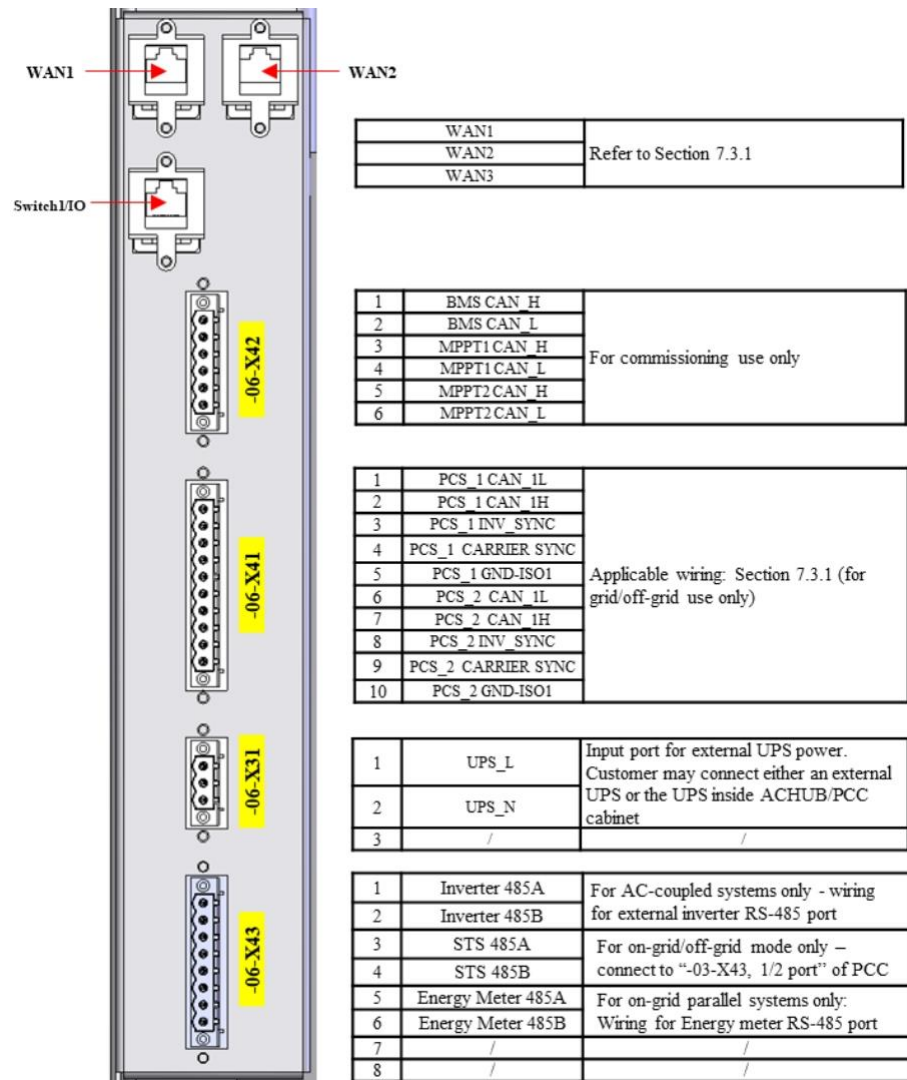

7.3.1 Parallel Wiring of Multiple PCS

For parallel operation of multiple C&I BESS units with a PCC cabinet, connect the PCS and STS communication cables as shown below (example: 3 BESS units + 1 PCC).

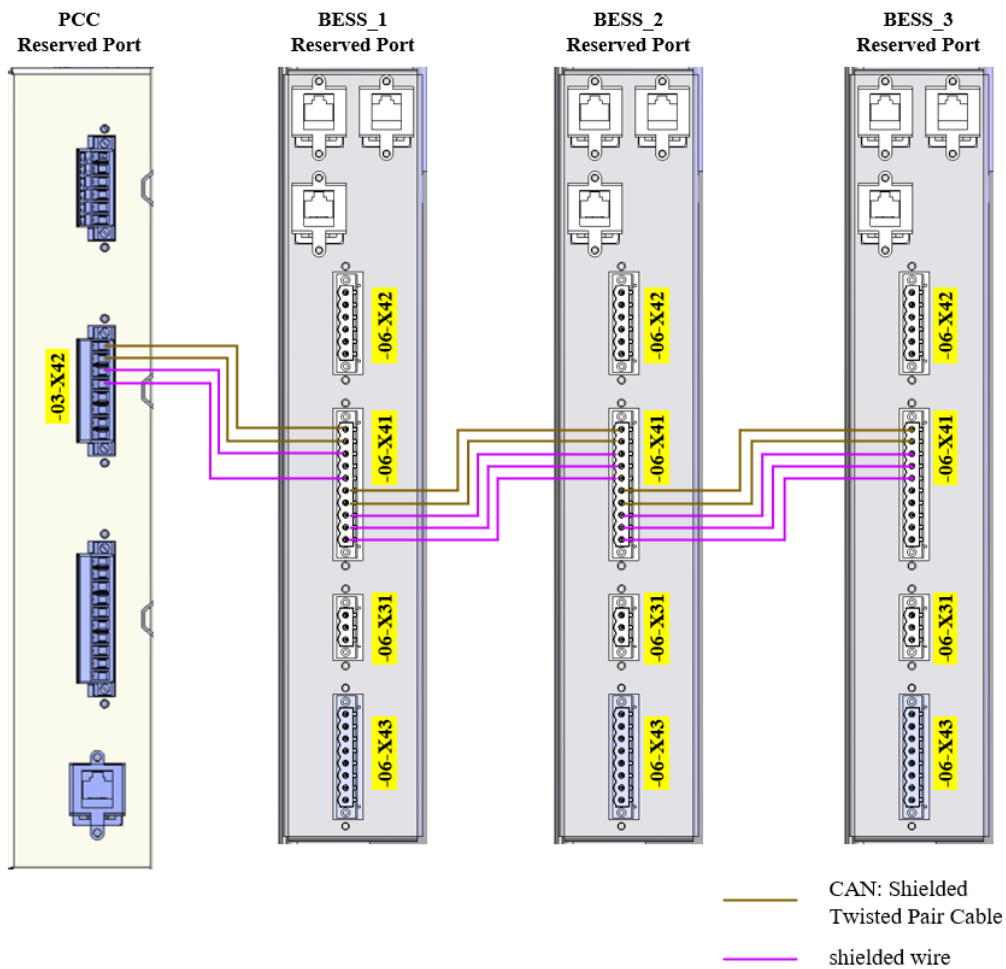
Figure 7-4 PCS and STS Communication Wiring for C&I BESS + PCC Application

7.3.2 EMS Wiring

When multiple energy storage systems are operated in parallel, an ACHub/PCC is configured. A -01-Switch1 switch is installed inside the ACHub/PCC for data exchange among multiple EMS units. A northbound controller is used for northbound communication in specific scenarios.

Table 7-3 Reference Wiring for Different Scenarios

Scenario	Reference Wiring Diagram
Single BESS	Figure 7-5
<ul style="list-style-type: none"> ● Pure storage scenario for multiple BESS (single site) ● AC-coupled PV+ESS scenario for multiple BESS 	Figure 7-6

Scenario	Reference Wiring Diagram
(single site)	
<ul style="list-style-type: none"> Pure storage scenario for multiple BESS (Microgrid) AC-coupled PV+ESS scenario for multiple BESS (Microgrid) 	Figure 7-7
DC-coupled PV+ESS scenario for multiple BESS (single site)	Figure 7-8
DC-coupled PV+ESS scenario for multiple BESS (Microgrid)	Figure 7-9

Figure 7-5 Northbound Communication Wiring for Single EMS

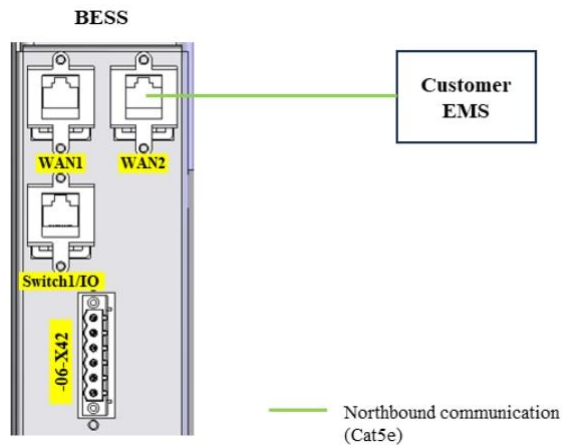

Figure 7-6 EMS Data Exchange and Northbound Communication Wiring for Multiple Pure ESS and AC Coupled PV+ ESS Systems (Single Site)

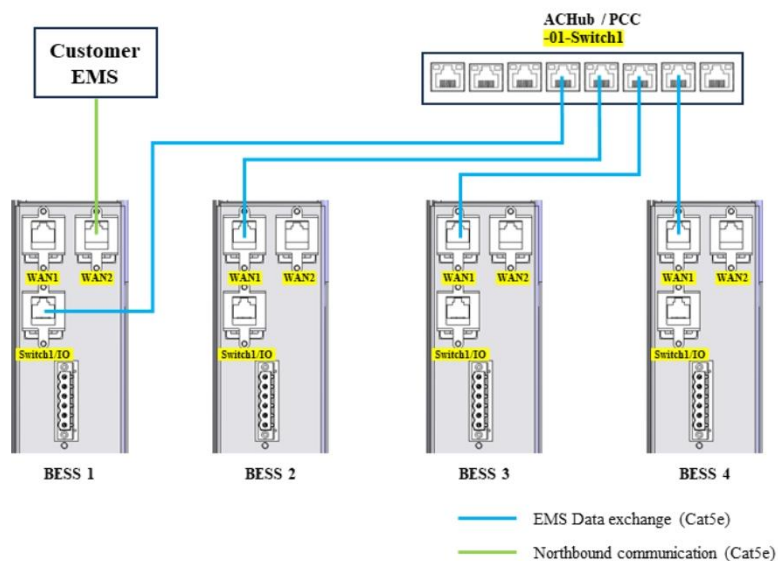

Figure 7-7 EMS Data Exchange and Northbound Communication Wiring for Multiple Pure Storage and AC Coupled PV+ ESS Systems (Microgrid)

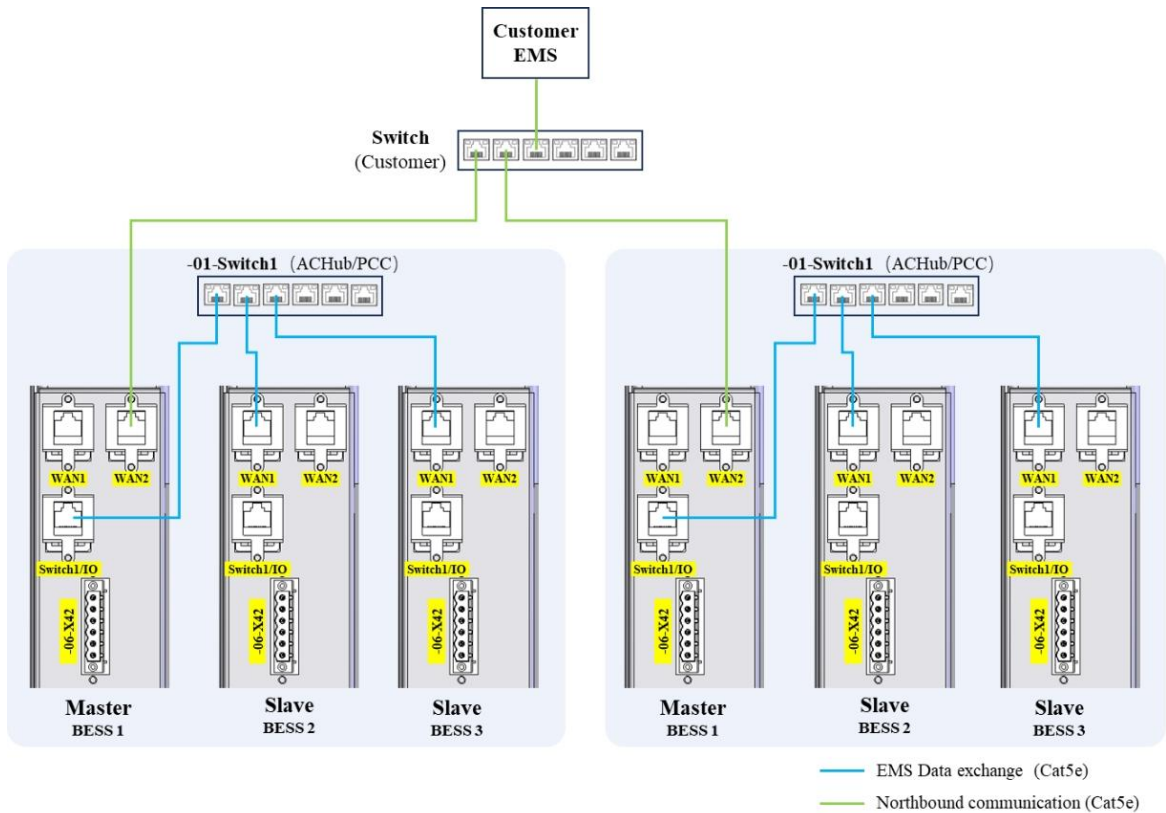

Figure 7-8 EMS Data Exchange and Northbound Communication Wiring for Multiple DC Coupled PV + ESS Systems (Single Site)

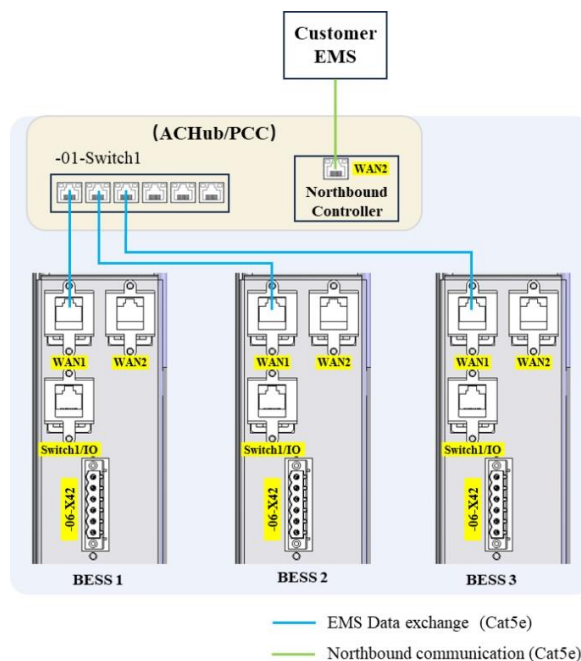
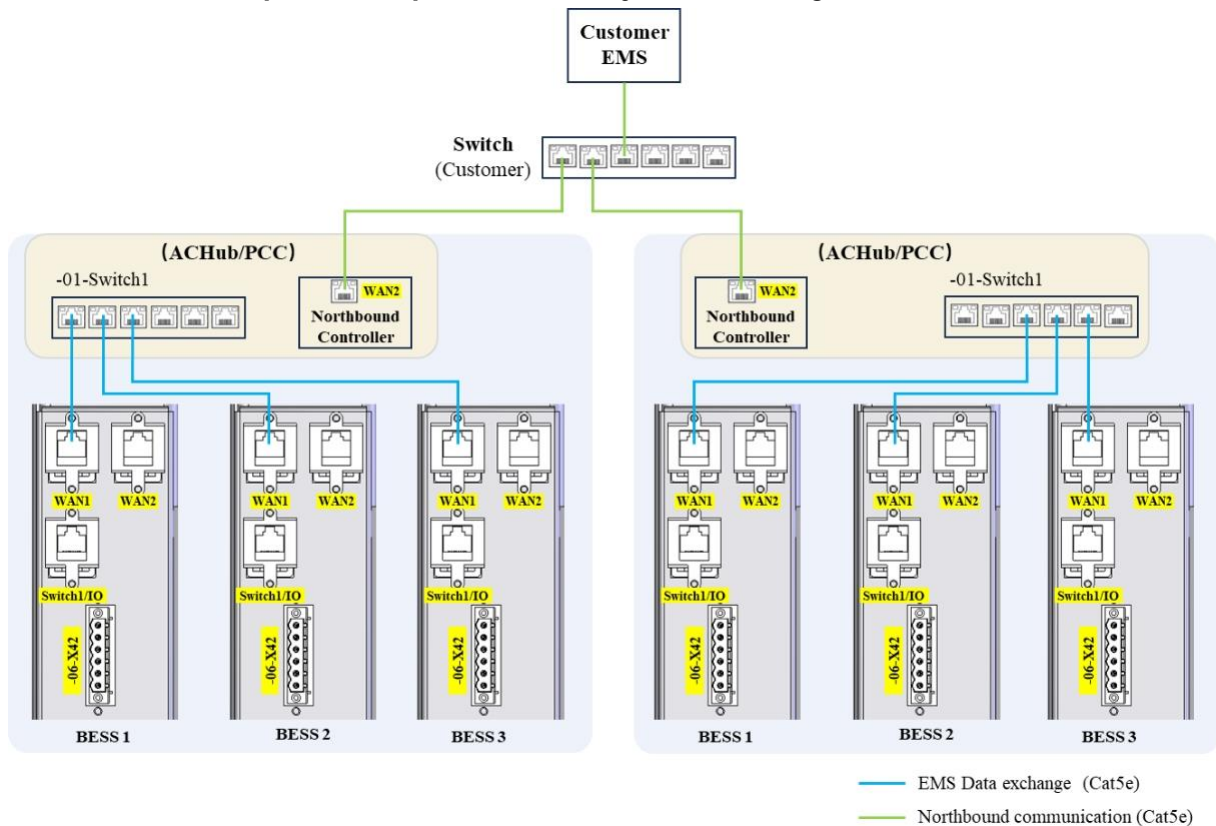

Figure 7-9 EMS Data Exchange and Northbound Communication Wiring for Multiple DC Coupled PV + ESS Systems (Microgrid)



7.4 Power Cable Installation

7.4.1 AC Power Cable Installation

Procedure

- Step 1: Remove the front and bottom cover plates of the circuit breaker, and feed the cable into the cabinet.
- Step 2: Cut open the rubber grommet on the cable entry plate and pass the cable through the grommet.
- Step 3: Connect the AC power cable to the lower copper busbar of the circuit breaker.
- Step 4: Perform torque inspection on the wiring connection.
- Step 5: Reinstall the bottom cover plate of the circuit breaker.

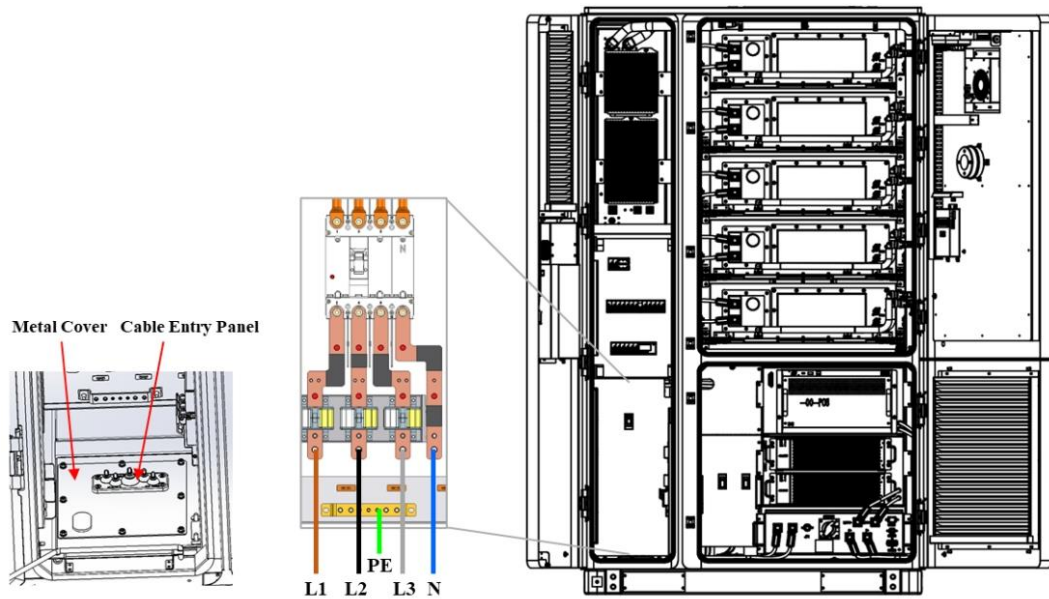
Figure 7-10 AC Power Cable Connection Position and Phase Sequence

Table 7-4 AC Side Short-circuit Current

Item	Value
AC side Short-circuit Current	9kA
Minimum Prospective Short-Circuit Current on AC side	6kA

Note: Install the Type B 30 mA residual current device and the circuit breaker with the rated current of 250A and in the external circuit between the equipment and the power grid.

7.4.2 PV Power Cable Installation (Only for MPPT Use)

Procedure

- Step 1: Remove the front and bottom cover plates of the circuit breaker.
- Step 2: Cut open the rubber grommet on the cable entry hole and pass the cable through.
- Step 3: Connect the DC power cable to the lower copper busbar of the PV circuit breaker.
- Step 4: Perform torque inspection on the wiring connection.
- Step 5: Reinstall the front cover plate of the circuit breaker.

Figure 7-11 PV Power Cable Connection Position

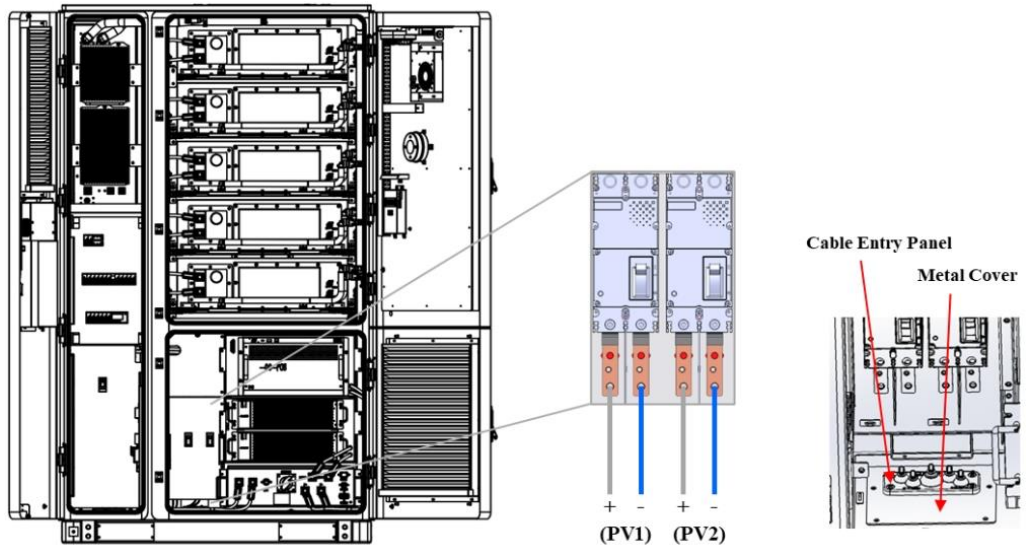

8 ESS Power-On and Power-Off

8.1 Check Before Power-On

8.1.1 General Check

No.	Check Items	Acceptance Criteria
1	ESS appearance	<ul style="list-style-type: none"> ● The appearance of the ESS is intact and free from damage, rust and paint loss. If there is any paint falling off, please carry out the operation of replacing the paint. ● The cabinet door should open and close smoothly, with sealing strips free from aging or damage, and should fit tightly when closed. ● ESS labels are clearly visible, damaged labels should be replaced promptly.
2	Cable appearance	<ul style="list-style-type: none"> ● The cable protection layer is well wrapped without visible damage. ● Cable hoses are in good condition.
3	Cable connection	<ul style="list-style-type: none"> ● The cable connection position is the same as the design. ● The terminals are made in accordance with specifications, and the connections are firm and reliable. ● The labels on both ends of each cable are clear and the labels are oriented in the same direction.
4	Cable wiring	<ul style="list-style-type: none"> ● Alignment meets the principle of separation of strong and weak power. ● The cables are neat and beautiful. ● Cable joints should be neatly cut and no spikes should be exposed. ● Leaving a margin at the turning point as required, and not pulling it tight. ● Straight and smooth wiring, no crossover of cables in the cabinet.
5	Copper busbar for external harness	<ul style="list-style-type: none"> ● No deformation of copper rows and no breakage of dip molding. ● The busbars must be securely installed, and the threaded holes

No.	Check Items	Acceptance Criteria
	Connection	should be properly aligned and installed.
6	AC Switch	<ul style="list-style-type: none"> ● The external AC switch of the power distribution cabinet is OFF. ● The energy storage cabinet AC switch is OFF.

8.1.2 ESS Installation and Check

Cabinet

No.	Check Items	Acceptance Criteria
1	Installation	Ensure the cabinet is securely fixed to a level surface or base using bolts or brackets. It should be stable, with no shaking or tilting. Seismic reinforcement measures must comply with design requirements.
2	Surface	The cabinet surface should be free from visible deformation, scratches, rust, and the paint finish should be intact. The cabinet door should open and close smoothly; sealing strips must not be aged or damaged and should fit tightly when closed.
3	Cabinet Grounding	Each cabinet has at least two grounding points, and grounded firmly, lap resistance $\leq 0.1\Omega$.
4	Accessories	External accessories must be correctly specified and installed in the required quantity.
5	Identification	Correct, clear and complete identification.

Internal

No.	Check Items	Acceptance Criteria
1	Circuit Breaker	The circuit breaker is in the open position.
2	Copper Busbar	Busbars should be free from deformation, and the insulating coating (plastic dip) must be intact. Busbars must be firmly installed, and threaded holes for wiring connections must be properly positioned and functional.
3	Cables	Cable mounting bolts have been tightened, and there is no looseness in cable pulling.
4	Battery Pack	Battery modules must be securely installed, with no looseness or displacement. Quick connectors between modules should be firmly connected. Battery surfaces must be free from swelling, leakage, or signs of overheating such as discoloration, yellowing, or deformation of the casing.
5	Foreign Object	Remove all foreign objects inside the cabinet, such as tools, installation residual materials, etc.

No.	Check Items	Acceptance Criteria
6	Distribution Area Baffle and Other Cover/Panel	No cracks, dents, scratches, splits, or looseness in the appearance of the power distribution area baffle. Required silkscreen markings must be accurate, clear, and legible.
7	Surge Protector	Lightning protector status indication is green.
8	Subcomponent	All subcomponents should be free from external damage, and wiring should be properly connected.
9	Cabinet Grounding	The grounding conductor is reliably connected to the cabinet grounding terminal board or copper row.

8.2 Power-On and Power-Off Operations

Figure 8-1 Auxiliary Power Distribution Components

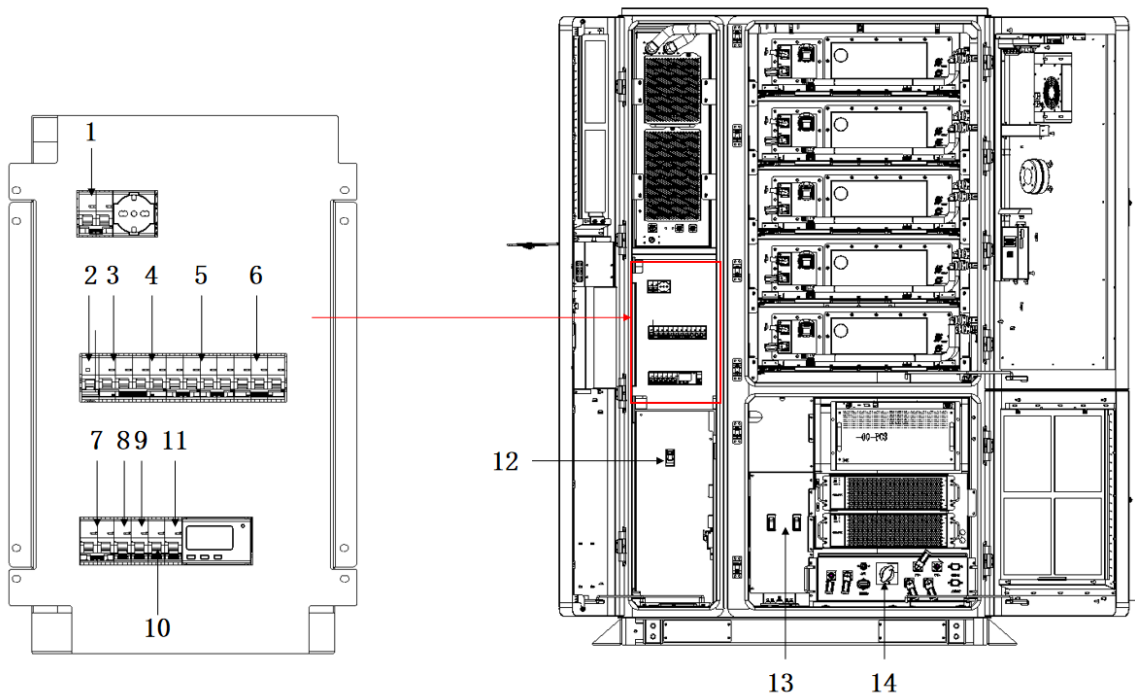

Table 8-1 Auxiliary Power Distribution Components

No.	Item	Function
1	-01-QF10	Socket Circuit
2	-01-S1	Switch
3	-01-QF2	Mains Power
4	-01-QF3	External UPS
5	-01-QF1	Auxiliary Power
6	-01-QF4	Voltage Sampling (Meter)
7	-01-QF5	24V
8	-01-QF6	HAVC
9	-01-QF7	Light
10	-01-QF8	Dehumidifier
11	-01-QF9	FAN
12	-00-QF3	PCS Breaker
13	-00-QF1, -00-QF2	PV1 Breaker, PV2 Breaker
14	-02-QF1	PDU Breaker

Power-On Procedure and Precautions

Step 1: Close "Auxiliary Power"; set "Socket Circuit" handle to the upward position.

Step 2: Close "Mains Power" and "24V".

Step 3: Sequentially close "Voltage Sampling (Meter)", "HAVC", "Dehumidifier", and "FAN".

Step 4: Close "PDU Breaker".

Step 5: Close "PCS Breaker".

Step 6: Close "PV1 Breaker", "PV2 Breaker" (optional, if PV strings are connected).

---End---

After completing the steps in sequence, the grid is powered on and the AC circuit is activated.

If the BESS is operating normally, the operation indicator will flash, while the fault and alarm indicators will remain off.

The system will then enter standby mode and wait for external commands.

Power-Off Procedure and Precautions

Step 1: Disconnect "PV1 Breaker", "PV2 Breaker" (optional, if PV strings are connected).

Step 2: Disconnect "PCS Breaker".

Step 3: Disconnect "PDU Breaker".

Step 4: Sequentially disconnect "Voltage Sampling (Meter)", "HAVC", "Dehumidifier", and "FAN".

Step 5: Disconnect "Mains Power" and "24V".

Step 6: Disconnect "Auxiliary Power".

---End---

After completing the steps in sequence, the ESS will shut down.

Before performing maintenance, the maintenance switch must be disconnected.

Wait for five minutes after shutdown before carrying out any inspection or servicing tasks.

9 System Commissioning

Prerequisites

- All the ESS at the site has completed the on-site commissioning.
- The system has been successfully powered on and the alarms have been eliminated.
- The site has the commissioning ESS that can be used for the opening.

9.1 Local Startup

The device is in the power-on state, check whether the alarm or fault indicator for device status, etc. is blinking, if not, continue the following operation; if the product has alarms or faults, enter the EMS interface, click on Alarm, take a picture of the fault information, and contact the distributor of the product to apply for after-sales service.

After there is no fault information, you can start the system directly through EMS, the specific operation of EMS can refer to the EMS user manual.

9.2 IP Address Settings

Procedure

Step 1: Click Device > Port in the left panel

Step 2: Select WAN at the top

Step 3: Configure the IP address, gateway address, mask address and type of WAN2 port based on the dispatching EMS IP.

Step 4: Click Restart SYS in the bottom right corner, then click Sure in the Operation Confirmation dialog.

Figure 9-1 Port WAN Interface

9.3 Scheduling Instructions

Data reading and scheduling according to the product protocol, the main functions are start, stop, charging, discharging, etc.; detailed scheduling protocol is provided separately.

- After the system start/stop command input exceeds the limit, the system will not execute any action or modify the wrong command.
- After the system power input exceeds the limit, the system will actively modify the command to the maximum charging and discharging power.
- System full and discharge stop is judged according to the voltage of a single battery, the maximum voltage of 3.6V is judged as full, and the minimum voltage of 2.8V is judged as discharge; when the system is full, continuing to issue the charging power will not be executed, and only the discharging power; when the system is discharged, continuing to issue the discharging power will not be executed, and only the charging power will be executed; the reversed power will make the change of the SOC after being full or discharged and it will Restriction is automatically restored.
- If the system level filling and emptying protection fails, the BMS level filling and emptying protection will be activated, and after the activation, it needs to be manually restored.
- The system SOC is a reference value, calculated according to the battery configuration and current value, but the battery capacity and current value have errors and are not accurate, so it is not recommended to use the SOC as a judgment condition for filling and emptying for system scheduling.

- Multiple TCP connections cannot exist at the same time, because the bottom is 485 communication, and multiple connections will lead to communication conflicts.
- Multiple threads cannot request data at the same time for a single TCP connection.
- The recommended interval time for each frame is 100ms or more.

Table 9-1 Communication Protocol

Address	Address (HEX)	Read/Write	Name	Data Type	Gain	Unit	Explanation
30031	0x754F	RO	Operating status	I32	1	-	0: Shutdown; 1: Starting up; 3: Starting up; 5: Standby; 9: Running; 32: Fault; 257: Running; 64: Fault; 8256: Fault
30033	0x7551	RO	Online	I32	0	-	0: Offline; 1: Online
30047	0x755F	RO	Current grid phase sequence	F32	1	-	0: Positive sequence; 1: Negative sequence
30013	0x753D	RO	AC output total active power	I32	0.1	kW	-
30015	0x753F	RO	AC output total reactive power	I32	0.1	kVar	-
30061	0x756D	RO	AC output total apparent power (kVA)	I32	0.1	kVA	-
30087	0x7587	RO	Current actual charge/discharge mode	F32	1	-	1: AC current source mode (constant current, constant power); 0: DC voltage source mode (ACDC source usage)
30079	0x757F	RO	System fault	I32	1	-	0: Normal; 1: Fault
40035	0x9C63	RW	Set strategy mode	I16	1	-	0: Peak load shift; 1: Transformer capacity expansion; 2: Photovoltaic absorption; 3: Emergency backup power;
40005	0x9C45	RW	Set working mode	I16	1	-	0: Manual; 1:

Address	Address (HEX)	Read/Write	Name	Data Type	Gain	Unit	Explanation
							Strategy; 2: Remote
40113	0x9CB1	RW	Power on/off	I16	1	-	0: Off; 1: On;
40114	0x9CB2	RW	Set active power	F32	1	kW	
30041	0x7559	RO	Total active power	F32	1	kW	-
30043	0x755B	RO	Total reactive power	F32	1	kVar	-
30019	0x7543	RO	Number of alarms	I32	1	-	-
30021	0x7545	RO	Prohibited charging protection	I32	1	-	0: Unprotected; 1: Protected
30023	0x7547	RO	Prohibited discharging protection	I32	1	-	0: Unprotected; 1: Protected

10 Human-Computer Interaction

10.1 Function Overview

The Energy Management System (EMS) is an intelligent system for energy control and optimization. In an energy storage system, the EMS serves as the "brain," coordinating the efficient and synergistic operation of multiple energy sources such as photovoltaics (PV) and energy storage. It continuously monitors the generation, storage, and consumption status of each energy unit in real time, intelligently dispatches PV generation, and optimally manages the charging and discharging strategies of the energy storage system. Through precise energy management and optimized control, the EMS not only improves energy utilization efficiency but also reduces operational costs, achieving a win-win outcome of both environmental sustainability and economic benefits.

Figure 10-1 Local EMS Home Screen

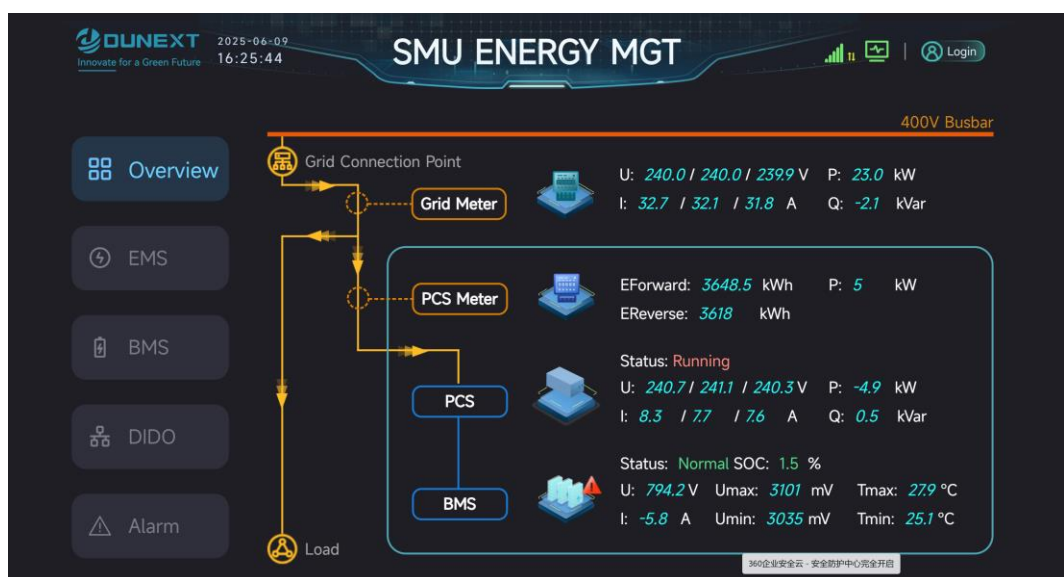
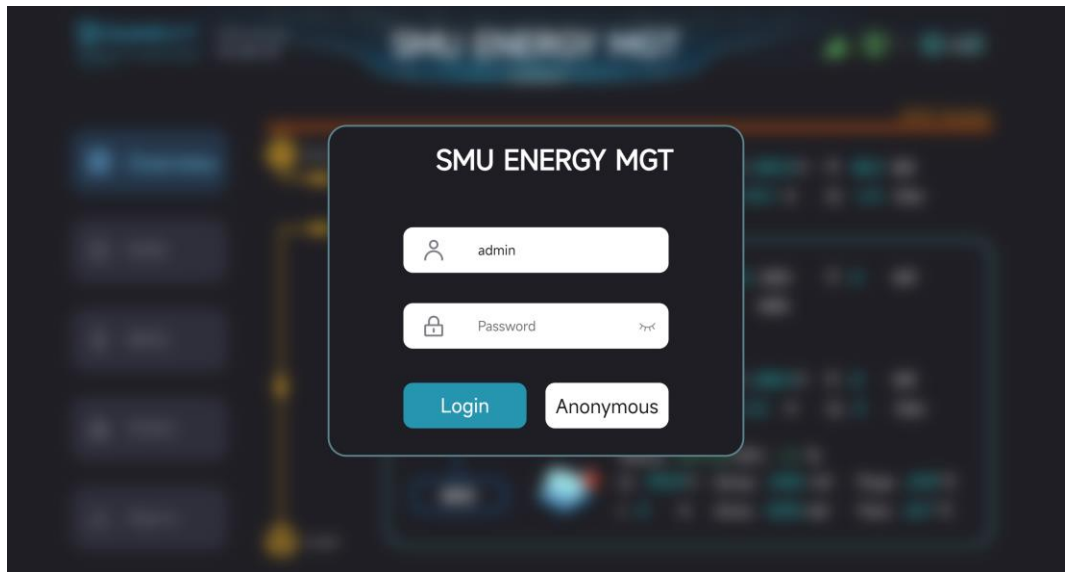
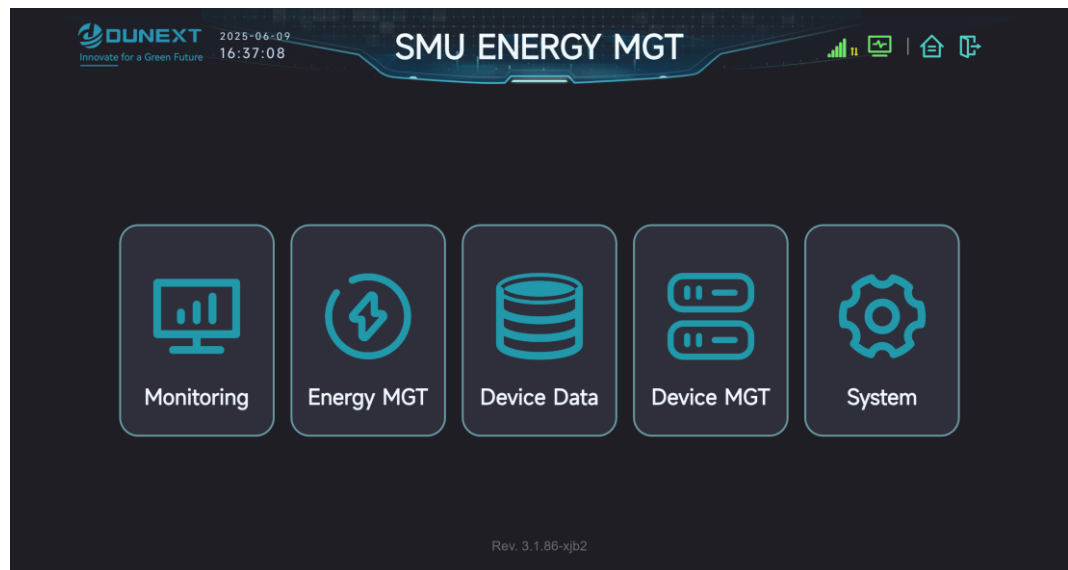

Figure 10-2 Login Screen



10.1.1 Monitoring

Figure 10-3 System Interface

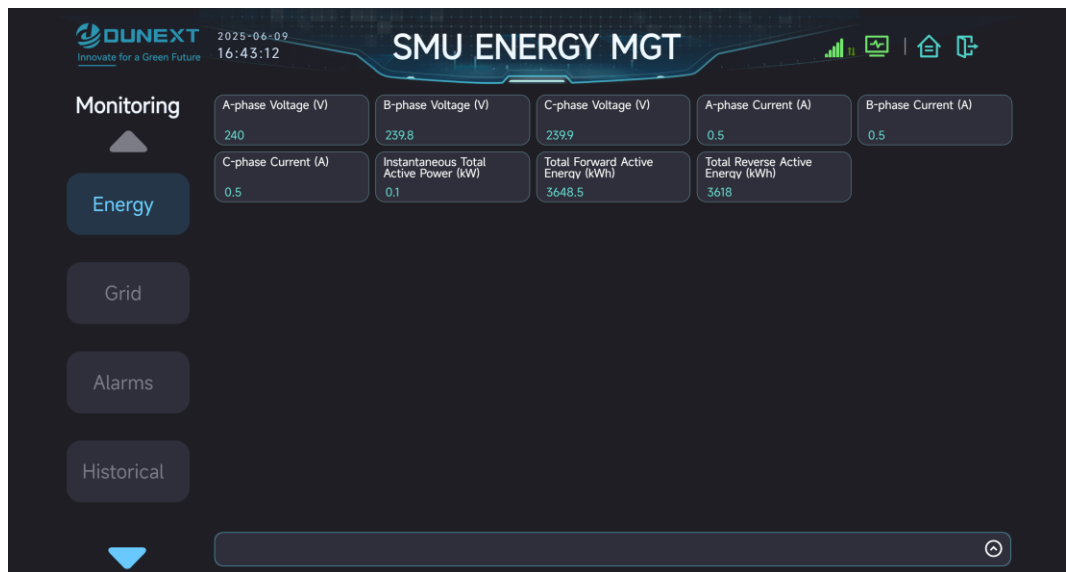

By clicking Monitoring on the main interface, users can view information such as energy data, grid data, and alarms.

Figure 10-4 Monitoring Interface

By clicking the page up or page down buttons, users can view all sub-function modules under Monitoring.

Energy

After entering the monitoring page, click Energy in the left panel.

Users can view the operational data of the internal energy meter, such as three-phase voltage and current, instantaneous total active power, and total forward active energy. This allows real-time monitoring of the energy storage system to promptly detect issues and take corrective actions, thereby maximizing energy utilization efficiency.

Grid

By clicking Grid in the left panel, users can check the operating status of the grid, including total apparent power, total active power, and total reactive power. This helps users quickly identify issues such as power backflow and demand control problems in the energy storage system.

Figure 10-5 Grid Interface

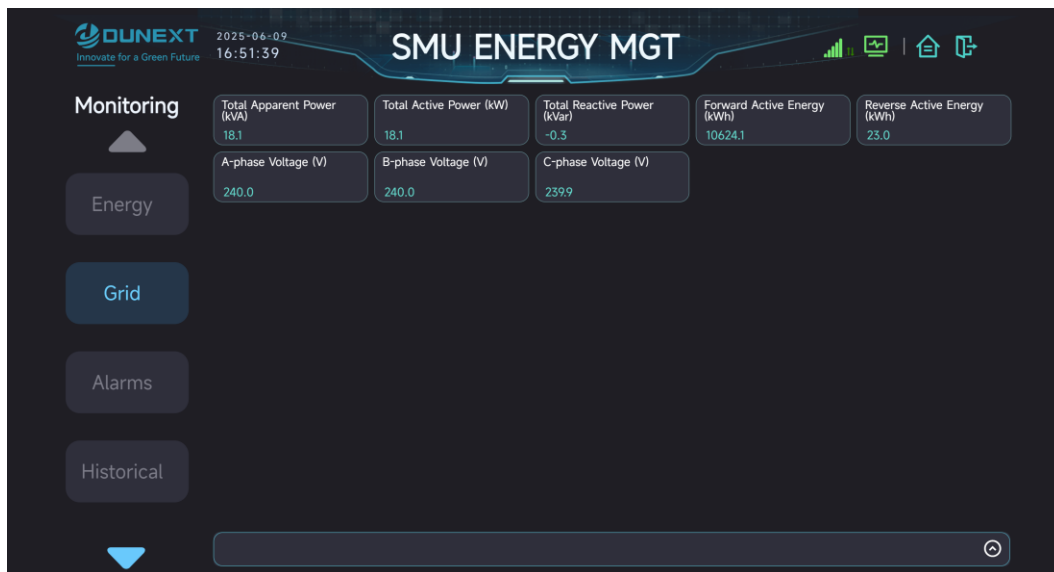

Alarms

By clicking Alarms in the left panel, users can view real-time alarm information in the energy storage system, including alarm time, alarm level, and alarm content. This enables timely detection of system or equipment issues and allows users to take appropriate measures to troubleshoot potential risks and ensure the normal operation of the energy storage system.

Figure 10-6 Alarms Interface

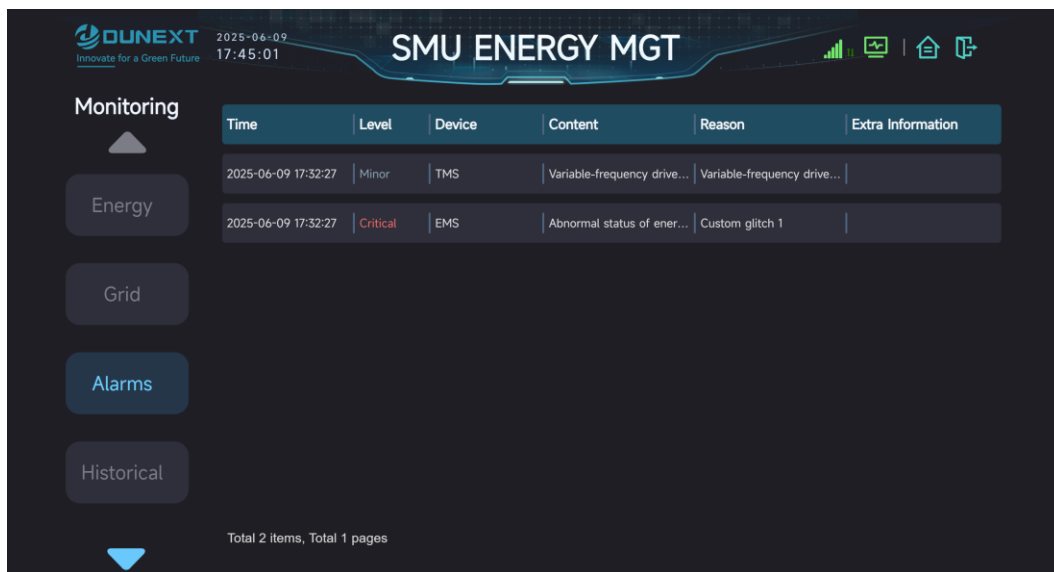

Historical

By clicking Historical in the left panel, users can view past alarm records that have already been cleared in the energy storage system, including the alarm time, recovery time, alarm level, and alarm content. This helps users diagnose and troubleshoot faults to maintain stable system operation.

Figure 10-7 Historical Interface

Time	Recovery Time	Level	Device	Content	Reason	Extra Information
2025-06-09 17:32:27	2025-06-09 17:36:17	Minor	MPPT2	MPPT equipment c...	MPPT equipment ...	
2025-06-09 17:32:27	2025-06-09 17:36:18	Minor	MPPT1	MPPT equipment c...	MPPT equipment ...	
2025-06-09 17:32:27	2025-06-09 17:33:38	Critical	PCS	Abnormal status of...	PCSFault	
2025-06-09 17:32:27	2025-06-09 17:32:51	Minor	PCS	EMS communicatio...	EMS communicati...	
2025-06-09 17:32:27	2025-06-09 17:33:38	Minor	PCS	Battery undervoltag...	Battery undervolt...	
2025-06-09 17:32:27	2025-06-09 17:33:38	Minor	PCS	EPO fault	EPO fault	
2025-06-09 16:48:23	2025-06-09 16:48:38	Minor	PCS	EMS communicatio...	EMS communicati...	

Total 1893 items, Total 271 pages Page 1

About

By clicking About in the left panel, users can view information such as SIM card number, site number, controller number, installed capacity, and EMS version.

Figure 10-8 About Interface

Name	Content
SIM card number	89861124204086269006
Site number	218831000232
Controller number	218831000232
Installed capacity(kW)	233 kWh
EMS version	1.76.100_15_weiwang_duneng_new_a9c2e78a
Number of EMS	1

Utilization

By clicking Utilization in the left panel, users can check the current resource usage of the energy storage system, including memory, hard disk, and extended disk. This helps identify system performance bottlenecks.

Figure 10-9 Utilization Interface

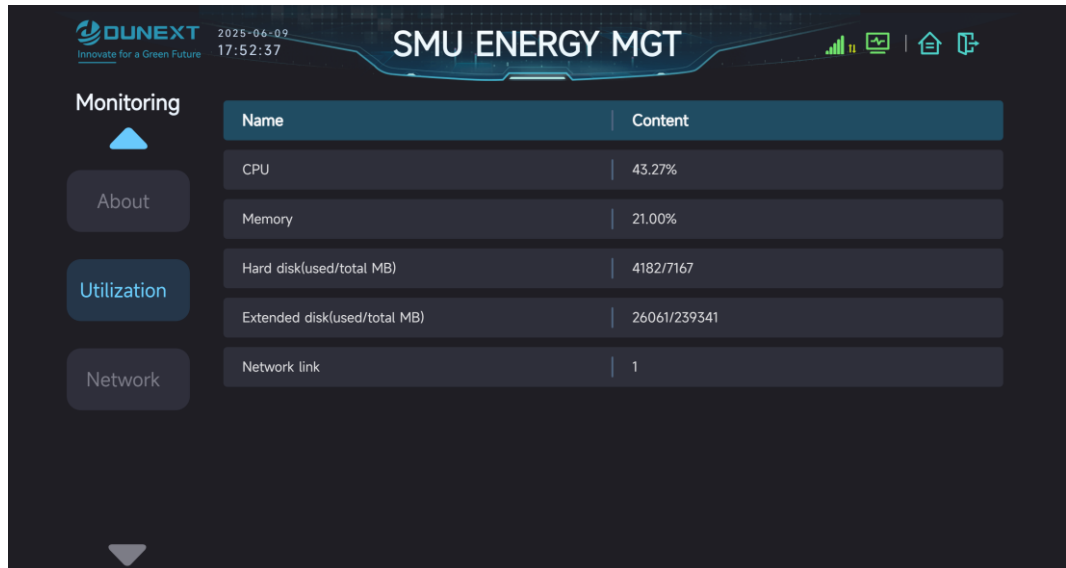

Network

By clicking Network in the left panel, users can view the current network status of the energy storage system, including the network card, uplink, and downlink.

Figure 10-10 Network Interface

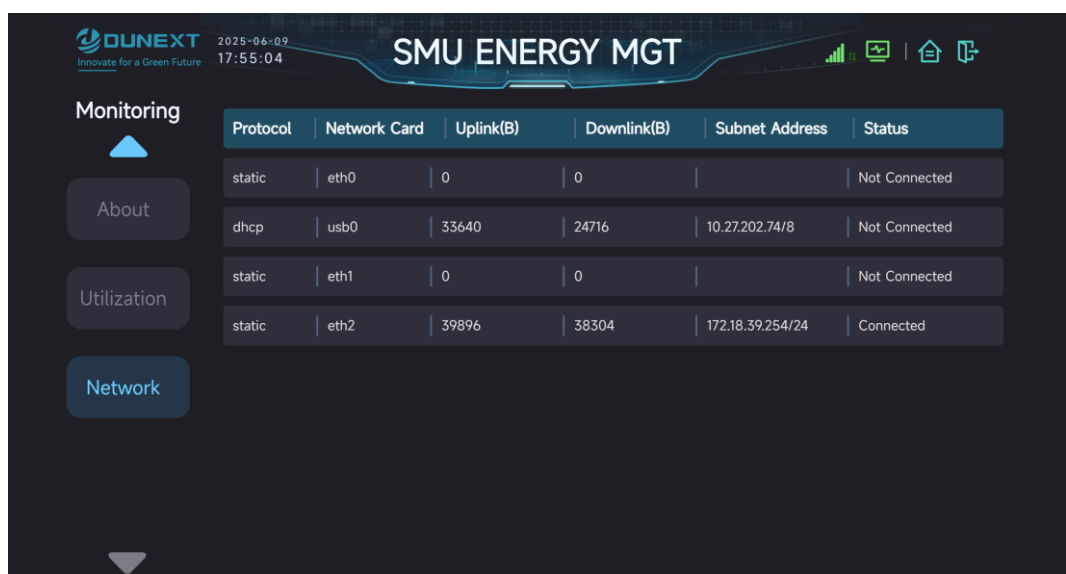

Table 10-1 Network Card and Network

Network Card	Network
usb0 4G	usb0 4G
eth0 WAN1	eth0 WAN1
eth1 WAN2	eth1 WAN2
eth2 LAN	eth2 LAN

10.1.2 Energy MGT

By clicking Energy MGT on the main interface, users can view and configure information related to strategy protection parameters, automatic strategy management, manual control, remote management, and subsystems. Energy management is one of the key functions of the EMS, enabling a better balance between energy supply and demand, refined control of charging and discharging strategies, and improved energy utilization efficiency and overall system performance.

Parameter

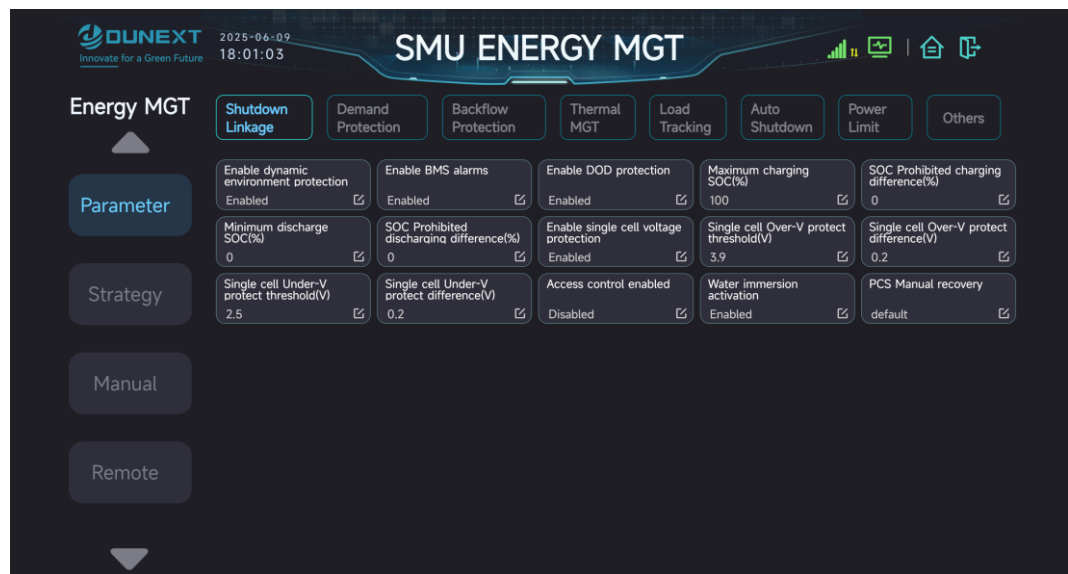
Figure 10-11 Parameter Interface

By clicking Parameter in the left panel, users can view and configure protection parameters such as shutdown linkage, demand protection, backflow protection, thermal MGT, load tracking, auto shutdown, and power limit.

Table 10-2 Parameter Description

Parameter	Unit	Description	Value
Enable dynamic environment protection	-	<p>Function: Switch to enable/disable PCS shutdown in response to environmental alarm signals.</p> <p>Description: When the EMS detects a dynamic environmental alarm, it immediately sends a shutdown command to the PCS.</p> <p>Enabled: Function is active</p> <p>Disabled: Function is inactive</p>	-
Enable BMS alarms	-	<p>Function: Switch to enable/disable PCS shutdown in response to BMS alarms.</p> <p>Description: When the EMS detects corresponding BMS alarms, it immediately sends a shutdown command to the PCS.</p> <p>Enabled: Function is active</p> <p>Disabled: Function is inactive</p>	-
Enable DOD protection	-	<p>Function: Switch to enable/disable battery depth-of-discharge protection.</p> <p>Description: EMS continuously monitors battery cluster SOC. Based on user-set thresholds, it automatically halts charging/discharging and activates Prohibited charging/discharging protection to prevent overcharging or overdischarging, thus extending battery life.</p> <p>Enabled: Function is active</p> <p>Disabled: Function is inactive</p>	-
Maximum charging SOC	%	Upper SOC threshold for charging. When the battery cluster SOC is greater than or equal to this value, EMS stops charging and activates Prohibited charging protection.	$0 < X \leq 100$
SOC prohibited charging difference	%	SOC difference threshold for EMS to cancel prohibited charging protection. When the battery cluster SOC falls below the maximum charging SOC minus this difference, EMS cancels the Prohibited charging protection.	$0 < X \leq 100$
Minimum discharge SOC	%	Lower SOC threshold for discharging. When the battery cluster SOC is less than or equal to this value, EMS stops discharging and activates Prohibited discharging protection.	$0 < X \leq 100$
SOC prohibited discharging difference	%	SOC difference threshold for EMS to cancel prohibited discharging protection. When the battery cluster SOC exceeds the minimum discharge SOC plus this difference,	$0 < X \leq 100$

Parameter	Unit	Description	Value
		EMS cancels the Prohibited discharging protection.	
Enable single cell voltage protection	-	<p>Function: Switch to enable/disable single cell voltage protection.</p> <p>Description: When EMS detects an overvoltage or undervoltage on any individual cell, it immediately stops charging/discharging and activates Prohibited charging/discharging protection.</p> <p>Enabled: Function is active</p> <p>Disabled: Function is inactive</p>	-
Single cell Over-V protect threshold	V	If the highest cell voltage is greater than or equal to this value, EMS immediately sends a shutdown command to PCS and activates Prohibited charging protection.	$1.5 \leq X \leq 4.5$
Single cell Under-V protect threshold	V	If the lowest cell voltage is less than or equal to this value, EMS immediately sends a shutdown command to PCS and activates Prohibited discharging protection.	$1.5 \leq X \leq 4.5$
Single cell Over-V protect difference	V	When the highest cell voltage drops below the overvoltage protection threshold minus this difference, EMS clears the Prohibited charging protection.	$1.5 \leq X \leq 4.5$
Single cell Under-V protect difference	V	When the lowest cell voltage exceeds the undervoltage protection threshold plus this difference, EMS clears the Prohibited discharging protection.	$1.5 \leq X \leq 4.5$
Access control enables	-	<p>When the door access system detects that the door is open, a fault alarm will be displayed on the EMS screen. At this point, the following actions must be taken:</p> <ol style="list-style-type: none"> Set the PCS active power to 0 and shut down the PCS. Power off the high-voltage box. Shunt-trip the auxiliary power switch and the main switch <p>At this stage, the indicator light on the energy storage cabinet will turn red.</p> <p>After manually confirming that the door is closed, reset the high-voltage cabinet, auxiliary power distribution switch, and main switch shunt trip.</p> <ul style="list-style-type: none"> Enabled: Function is active Disabled: Function is inactive 	-
Water immersion	-	When a water immersion signal is continuously	-

Parameter	Unit	Description	Value
activation		triggered for 10s, a fault alarm will be displayed on the EMS screen. At this point, the following actions must be taken: <ol style="list-style-type: none"> Set the PCS active power to 0 and shut down the PCS. Power off the high-voltage box. Shunt-trip the auxiliary power switch and the main switch At this stage, the indicator light on the energy storage cabinet will turn red. After manually confirming that the water immersion alarm is released, reset the high-voltage cabinet, auxiliary power distribution switch, and main switch shunt trip. <ul style="list-style-type: none"> Enabled: Function is active Disabled: Function is inactive 	
PCS manual recovery	-	Allows manual reset of PCS in case of alarms or faults.	-

10.1.3 Device Data

By clicking Device Data on the main interface, users can view the status, data, and alarms of each configured device in the system. Users can also set parameters for controllable devices, enabling intuitive monitoring and parameter adjustments, which reduces operational complexity.

Status

- Online indicates that the energy storage system is connected to and communicating properly with the EMS.
- Offline indicates abnormal connection or communication with the EMS. Please check whether the device is correctly connected to the EMS controller and whether the device configuration is correct.

Figure 10-12 Device Data Interface



Read Data

- The data tags displayed on the Read Data page are dynamically generated based on the connected devices.
- Red text indicates a failure in data reading. Please check if the device is online, if the connection is normal, and whether the device configuration is correct.
- Click the page navigation button at the bottom right to view more data of the energy storage system.

Figure 10-13 Read Data Interface

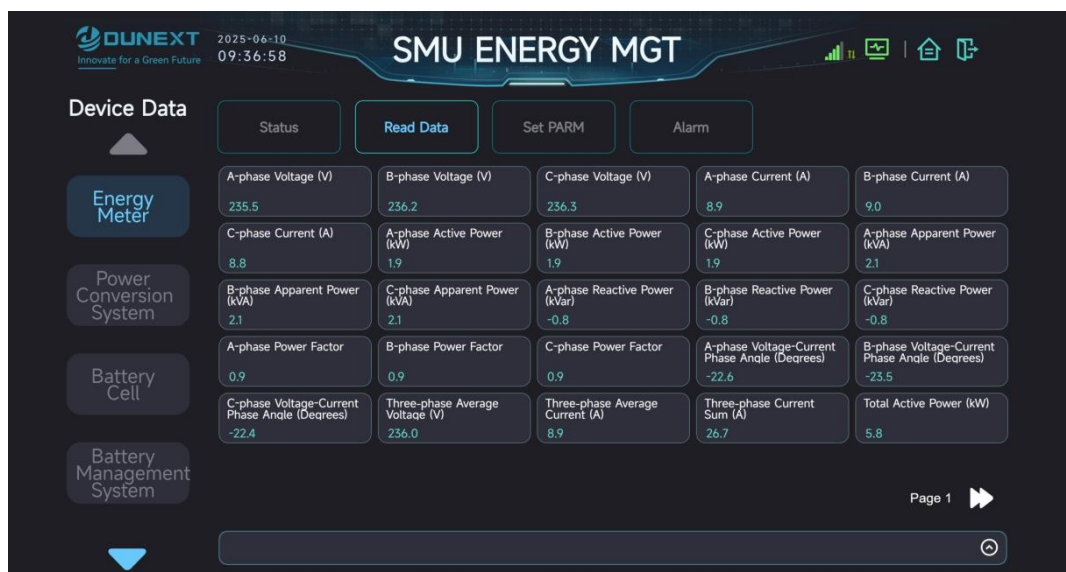

Set PARM

Whether the parameters of a device can be configured depends on the ESS connected to the EMS. Only configurable ESS will support parameter setting.

Figure 10-14 Set PARM



Alarm

Taking the PCS as an example, users can view real-time alarm information for the corresponding device.

Figure 10-15 Alarm Interface

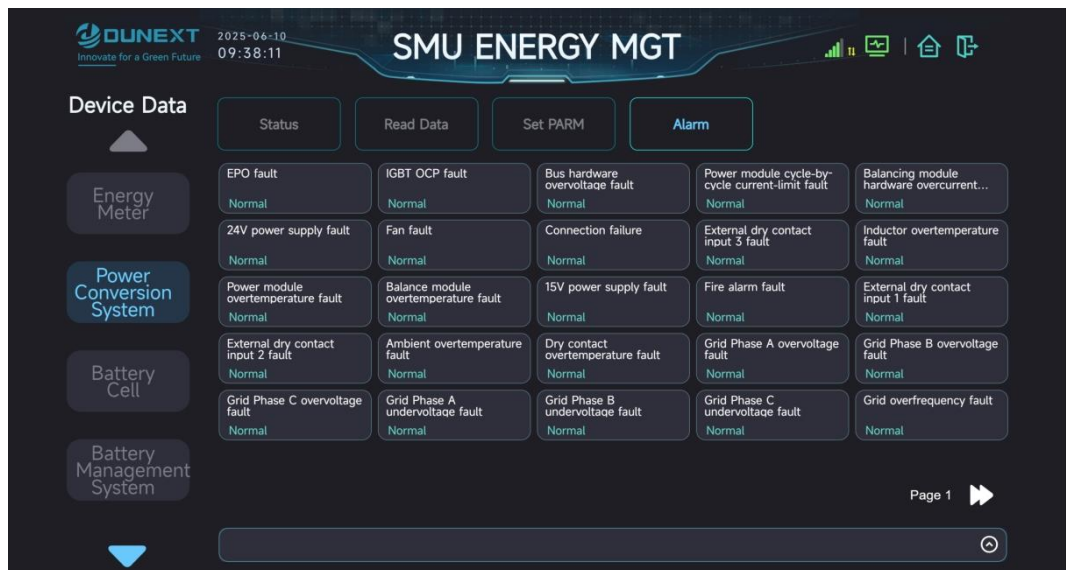

10.1.4 Device MGT

By clicking Device MGT on the main interface, users can view and configure the port and device settings of the current energy storage system. Users can also perform factory diagnostics or charge-discharge diagnostics, which makes device management smarter, more efficient and convenient.

Port

Figure 10-16 Port Interface



Set the required parameters according to the actual devices connected to each serial port.

Note: If an edit button appears on the right side of a parameter column name, the parameter is configurable.

Take the RS485 port as an example:

1. Click the parameter value area to be modified.
2. Configure the parameter in the pop-up Edit dialog.
3. After completing the parameter configuration, click Sure.
4. Click Write Config at the bottom right of the page.
5. To immediately apply the latest configuration to the energy storage system, click Restart SYS at the bottom right of the page, and in the pop-up Operation Confirmation dialog, click Sure.

Other port configurations follow similar steps.

Device

Select Device from the left panel to view and configure devices such as meters, PCS, and BMS. Energy storage systems must be configured under the corresponding device module. The EMS includes built-in templates for various types of energy storage systems. For customized templates, please select Controller at the top of the Operation page to import them in advance via Import Template. Device type, template, and protocol must be selected from the corresponding drop-down lists.

Figure 10-17 Default Device Interface



Example of configuring a meter:

Procedure

1. Click Device MGT > Device in the left panel.
2. Select the METER tab at the top.
3. Set the required parameters as needed. A parameter is configurable if an edit icon appears beside the column name.
4. Click the value area of the parameter to be modified.
5. Configure it in the pop-up Edit dialog.
6. After completing the parameter configuration, click Sure.
7. Click Write Config at the bottom right of the page.
8. To immediately apply the latest configuration to the energy storage system, click Restart SYS at the bottom right of the page, and in the pop-up Operation Confirmation Dialog, click Sure.

Other device configurations follow similar steps.

Diagnosis

From the left panel, select Diagnostics to perform Factory or Charge-Disch Diagnostics on the current energy storage system.

Figure 10-18 Diagnostics Interface

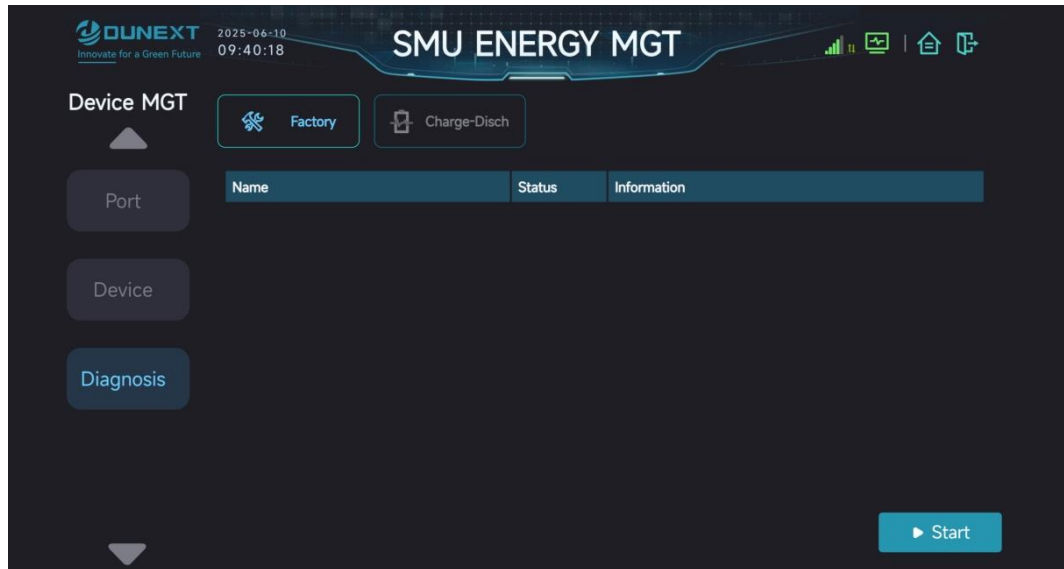

Factory Diagnostics

Procedure

1. Click Device MGT > Diagnostics in the left panel.
2. Select Factory at the top.
3. Click Start at the bottom right of the page.

Result

The screen displays the results of the factory diagnostics.

Charge-Disch Diagnostics

Procedure

1. Click Device MGT > Diagnostics in the left panel.
2. Select Charge-Disch at the top.
3. Click Start at the bottom right of the page.

Result

The screen displays the results of the charge-discharge diagnostics.

10.1.5 System

By clicking System on the main interface, users can configure the basic settings, connections, parameters, and operations of the energy storage system. This allows

users to flexibly adjust the energy storage system according to their needs and scenarios, while also performing software upgrades to ensure the system stays current with technological advancements.

Figure 10-19 System Interface

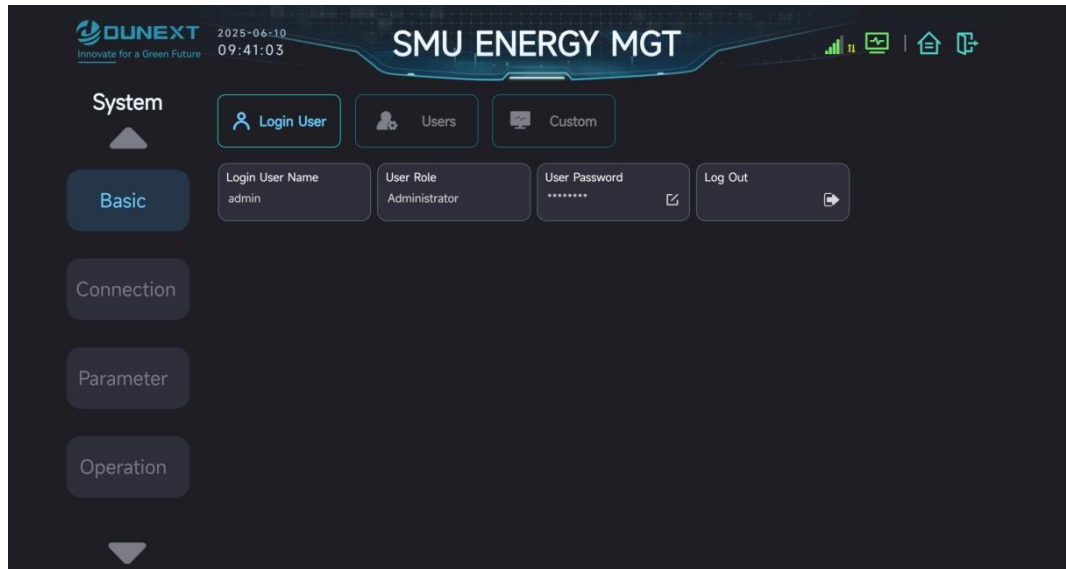

Basic

From the left panel, select Basic to change or reset the login password for the energy storage system, and upload a custom LOGO to personalize the interface.

Connection

From the left panel, select Connection to view information about established network connections, including name, IP address, port, username, etc.

Figure 10-20 Connection Interface

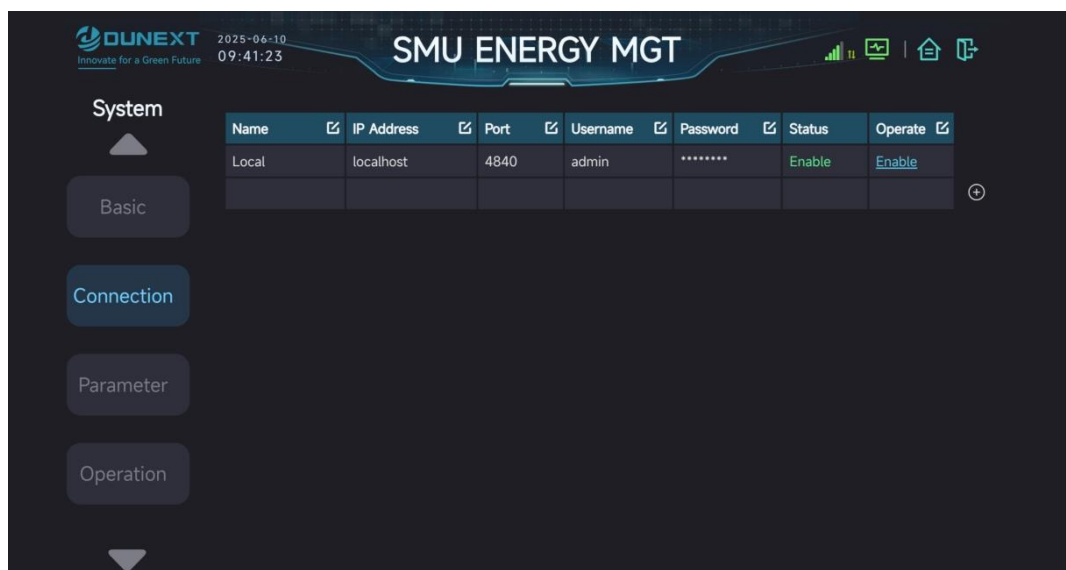

Parameter

From the left panel, select Parameter to view the current system cabinet number, installed capacity, and installed power.

Figure 10-21 Parameter Interface

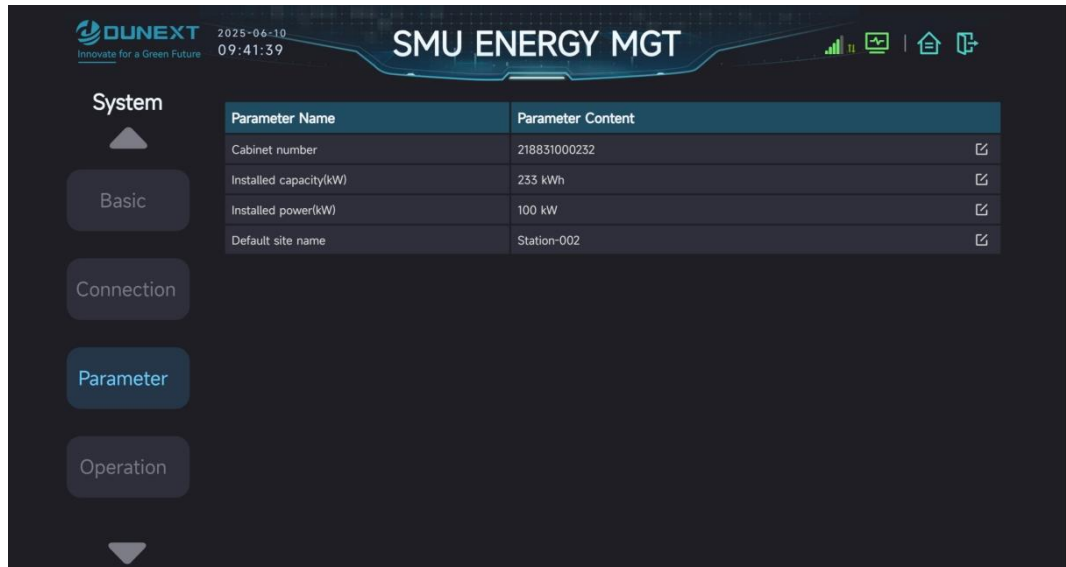

Operation

From the left panel, select Operation to perform operations such as system upgrades and restart.

Figure 10-22 Operation Interface

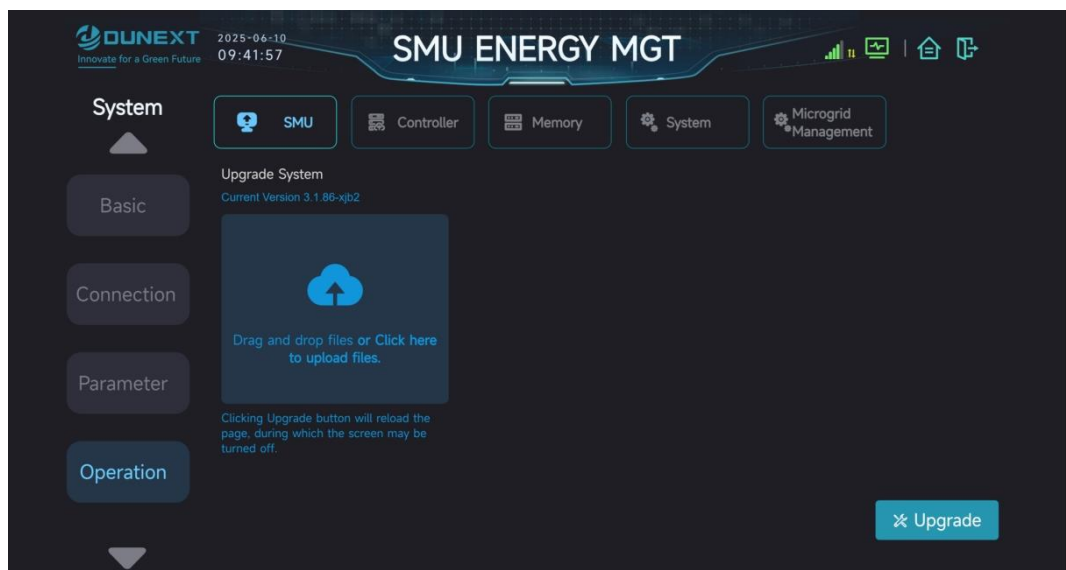

11

Operation, Maintenance, and Troubleshooting

To ensure proper operation of all devices inside the outdoor BESS, regular maintenance is required. The maintenance intervals provided in this section are for reference only. Actual maintenance intervals should be reasonably determined based on the specific environmental conditions of the project site. If the outdoor BESS operates in harsh environments—such as desert regions—the maintenance intervals should be shortened accordingly. In particular, internal and external cleaning, as well as anti-corrosion and rust prevention measures, should be carried out more frequently. For systems installed in desert areas, it is recommended to thoroughly inspect and clean the interior and exterior of the battery cabinet after each sandstorm.



WARNING!

- Regularly check the operation of the module cooling fans and other fans inside the battery cabinet. Pay attention to any abnormal noises such as friction sounds, which may be caused by dust ingress. If such issues occur, the battery cabinet must be shut down and the dust removed. After completely powering off the battery cabinet, wait at least 10 minutes to allow internal capacitors to discharge. Before cleaning, use a multimeter to confirm that there is no residual voltage inside the equipment to avoid electric shock.
- Most maintenance tasks require removal of protective meshes or covers inside the equipment. After all maintenance work is completed, be sure to reinstall all removed protective covers and ensure that all screws are securely fastened.
- During routine maintenance and inspections of devices inside the battery cabinet, immediately correct any nonconformities found. If you have any questions, please

contact Dunext promptly.

11.1 Monthly Operation & Maintenance Requirements

No.	Check Item	Check Method	Maintenance Interval
1	Appearance	Check if the cabinet exterior has paint peeling or rust.	Every Month
2	Cabinet Grounding	Check if grounding is reliable.	
3	Battery Cabinet O&M Requirements		
4	Sealing Strip	Ensure cabinet doors open and close smoothly; sealing strips should not be aged, damaged, or detached. They must fit tightly when closed.	
5	IP Rating Check	Check for water marks along cabinet door edges.	
6	Battery Mounting Bracket	Check for deformation or loose mounting screws.	
7	Battery Modules	Check for bulging, leakage, or pungent gases from the battery.	
8	Cables	Check if high-voltage and communication cables are damaged or disconnected.	
9	Module Indicators	Check if indicator lights of smoke detectors, temperature sensors, and combustible gas detectors are on.	
10	Dehumidifier	Verify the dehumidifier's parameters are accurate.	
11	Electrical Cabinet O&M Requirements		
12	Sealing Strip	Ensure cabinet doors open and close smoothly; sealing strips should not be aged, damaged, or detached. They must fit tightly when closed.	
13	IP Rating Check	Check for water marks along cabinet door edges.	
14	Louver	Check for blockages; inspect whether filter cotton needs cleaning.	
15	Circuit Breaker	Check if the DC main circuit breaker operates normally.	
16	Internal Power Meter	Check if the internal power meter is lit and displaying data correctly.	
17	Module Indicators	Check if indicator lights on the power supply module, IO controller module, and water leakage sensor module are on. Also check system status indicators.	
18	High-voltage Cables	Inspect cable connection points for signs of burning or torque marker changes.	
19	Air Filter Cleaning	<ul style="list-style-type: none"> ● Ensure the equipment is shut down and disconnected from power. ● Loosen the air filter screws (without fully 	

No.	Check Item	Check Method	Maintenance Interval
		removing) fixed on the device. <ul style="list-style-type: none"> Gently pull out the air filter, avoiding damage to internal components. Clean the air filter using a dry soft brush or vacuum cleaner. Reinstall the cleaned air filter and tighten screws in the correct sequence. 	
20	Liquid Cooling Unit O&M Requirements		
21	Operating Data	Verify the following parameters during unit operation: <ul style="list-style-type: none"> Current: Less than the maximum operating current indicated on the nameplate Voltage: 220V \pm15% Coolant operating temperature: -30°C to 55°C Return water pressure \geq 0.8 bar 	
22	Operating Sound	Ensure no abnormal vibration or noise; observe the following components: <ul style="list-style-type: none"> - Compressor - Fan - Circulation water pump 	
23	Pipeline Integrity	Ensure no refrigerant leakage in the cooling system and no coolant leakage in the circulation system.	
24	Appearance	The liquid cooling unit surface should be clean and free of dust and stains.	

11.2 Annual Operation & Maintenance Requirements

No.	Check Item	Check Method	Maintenance Interval
1	Cabinet Appearance	Conduct a visual inspection. Repaint any areas where paint has peeled off.	Every 12 months
2	Screws	Check for any fallen screws inside the outdoor BESS and AC outdoor cabinet.	
3	Wiring Fixing Screws Tightness	Ensure that external harness fixing screws are tightened to the specified torque.	
4	Wall Bushing Components	Inspect IP rating integrity of wall bushings across different models.	
5	Dust Removal in Electrical Cabinet	Use a vacuum cleaner to remove dust inside the electrical compartment.	
6	Fan Operational Reliability	<ul style="list-style-type: none"> Check PCS and MPPT module fans for dust or foreign object blockage. 	

No.	Check Item	Check Method	Maintenance Interval
		<ul style="list-style-type: none"> Inspect for damaged fan blades and verify that the fan spins smoothly without abnormal noise. 	
7	Liquid Cooling Unit O&M Requirements		
8	Fan Operational Reliability	<ul style="list-style-type: none"> Check PCS and MPPT module fans for dust or foreign object blockage. Inspect for damaged fan blades and verify that the fan spins smoothly without abnormal noise. 	
9	Condenser Cleaning	<ul style="list-style-type: none"> Ensure there is no dust or foreign object blockage in the condenser. Confirm the fins are not severely bent or deformed. 	
10	Wiring Panel – Power Cable & Terminal Reliability	<ul style="list-style-type: none"> Check that power cables and terminals are not loose. Ensure cables are free from aging, damage, overheating, or other anomalies. Ensure there is no dust on the wiring panel. 	
11	Coolant	<ul style="list-style-type: none"> Appearance should be clear, with no sediment or suspended particles. pH > 7. Labelled freezing point must be within $\pm 2^{\circ}\text{C}$ of specified value. 	

11.3 Biennial Operation & Maintenance Requirements

No.	Check Item	Check Method	Maintenance Interval
1	System Status and Cleanliness	<ul style="list-style-type: none"> Inspect the following items; correct any issues immediately if found: Check whether any devices inside the outdoor BESS is damaged or deformed. Check for abnormal noises during device operation. Check whether the internal temperature of the BESS is excessively high. 	Every 24 months

No.	Check Item	Check Method	Maintenance Interval
		<ul style="list-style-type: none"> ● Check whether the humidity and dust levels are within the normal range; clean if necessary. ● Check whether air inlets and outlets are blocked. 	
2	Warning Labels	Check whether warning labels and signs are clearly visible and undamaged. Replace if necessary.	
3	Cable Shield Grounding	Verify that cable shielding layers are in good contact with insulation sleeves and that the grounding busbar is securely fixed.	
4	Surge Protection Devices and Fuses	Check whether surge protection devices and fuses are in good condition and firmly installed.	
5	Corrosion Condition	Inspect the interior of the outdoor BESS for signs of oxidation or corrosion.	
6	Air Filter Replacement	Replace the air filter cotton in the electrical cabinet.	

11.4 ESS Troubleshooting

Table 11-1 Common Troubleshooting

No.	Fault Name	Solution
1	IO controller communication interruption	Check IO controller communication harness
2	Battery cell voltage high voltage fault	Notify the manufacturer
3	Differential cell voltage fault	Notify the manufacturer
4	BMM communication failure	Check BMM communication harness
5	High temperature of air inlet and outlet	Check the air inlet and outlet for blockage
6	Grid phase sequence alarm	Check for correct wiring sequence on the grid side
7	Electricity becomes low	Calibrate SOC

12 Technical Data

Model	PowerHill (233kWh)
Battery	
Cell Type	LFP-280Ah
Pack Configuration	1P52S
Battery Capacity [kWh]	233kWh
Overvoltage Category	OVC II
AC Output	
Connection Type	3L/N/PE
Charging/Discharging Power [kW]	100/105
Rated Grid Voltage [V]	400
Frequency [Hz]	50
Rated AC Output Current [A]	145/152
Power Factor	1 lagging – 1 leading
Output THDi [@Rated Output]	< 3% (Linear Load)
Overvoltage Category	OVC III
General Parameters	
Dimensions [W * H * D] [mm]	(1390±3) * (2380±3) * (1350±3)
Weight [kg]	< 3000
Degree of Protection	IP54
Cooling Method	Liquid Cooling
Fire Suppression System	Aerosol
Anti-Corrosion Grade	C3
Pollution Degree	3
Relative Humidity	0-100%RH
Operating Temperature [°C]	-25 ~ 55 (Derating above 45°C)
Altitude [m] [1]	2000
Noise Level [dB]	< 70
Communication Interface	Ethernet, Optical Fiber (Customized)
Communication Protocol	MQTT, Modbus TCP, IEC104, IEC61850 (Customized)

Model	PowerHill (233kWh)
PV Side Parameters (Optional)	
Max. PV Input Power [kW]	60*2
PV Input Voltage Range [V]	300~670
Number of MPPTs	2
Number of PV Inputs	2
Max. Input Current [A]	200*2
Overvoltage Category	OVC II
[1] The system will be derated when the ambient temperature exceeds 45°C. [2] The system will be derated when the altitude is above 2000 m.	

A Crimp an OT / DT Terminal

Requirements on an OT or DT Terminal

- If a copper cable is used, use copper wiring terminals.
- If a copper-clad aluminum cable is used, use copper wiring terminals.
- If an aluminum alloy cable is used, use copper-to-aluminum wiring terminals, or aluminum wiring terminals along with copper-to-aluminum washers.

NOTICE

NOTICE!

- Do not connect aluminum wiring terminals to the terminal block. Otherwise electrochemical corrosion may occur, affecting the reliability of cable connections.
- Comply with the IEC 61238-1 requirements when using copper-to-aluminum wiring terminals, or aluminum wiring terminals along with copper-to aluminum washers.
- Do not mix up the aluminum and copper sides of a copper-to-aluminum washer. The outer contour of the washer shall not be smaller than that of the OT/DT terminal. Ensure that the aluminum side of the washer contacts the aluminum wiring terminal, and that the copper side contacts the terminal block. It is recommended that washers and terminals be purchased from the same vendor.

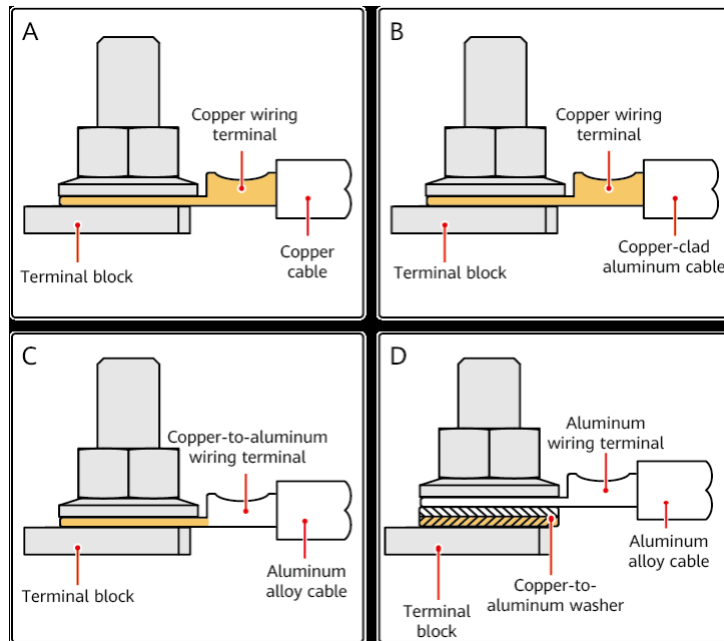
Figure A-1 Requirements on an OT or DT Terminal

Crimp an OT or DT Terminal
NOTICE
NOTICE!

- Avoid scratching the core wire when stripping a cable.
- The cavity formed after the conductor crimp strip of the OT or DT terminal has been crimped must wrap around the core wire completely. The core wire must make close contact with the OT or DT terminal.
- Wrap the wire crimping area with heat shrink tubing or insulation tape. The heat shrink tubing is used as an example. When crimping OT/DT terminals for electrical equipment, you must use heat shrink tubings.
- Use a heat gun carefully to avoid heat damage to the equipment.

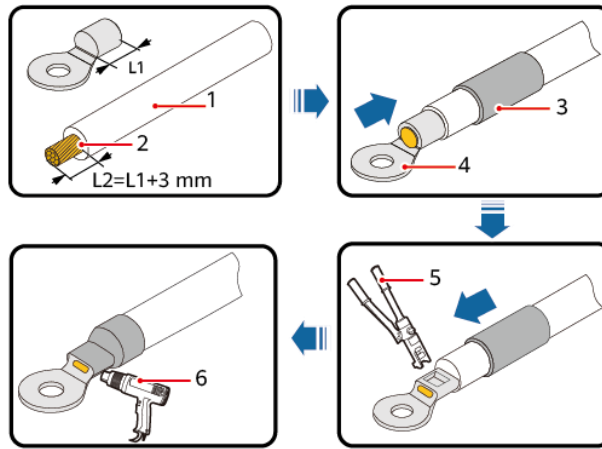
Figure A-2 Crimp an OT Terminal



- (1) Cable (2) Core wire (3) Heat shrink tubing
 (4) OT terminal (5) Hydraulic pliers (6) Heat gun

Figure A-3 Crimp a DT Terminal

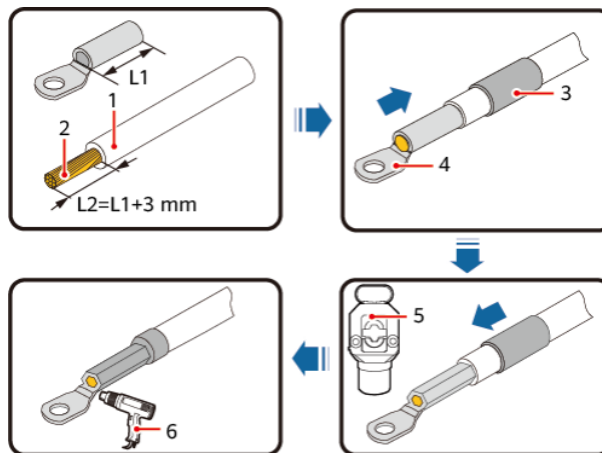

- (1) Cable (2) Core wire (3) Heat shrink tubing
 (4) DT terminal (5) Hydraulic pliers (6) Heat gun

B How to Repair Paint Damage

Check the appearance of the outdoor BESS and AC outdoor cabinet for signs of damage.

- Case 1: Surface dirt caused by water stains or dust; can be cleaned.
- Case 2: Surface dirt with paint damage; surface marks cannot be completely cleaned.
- Case 3: Primer layer is damaged, and the substrate is exposed.



Maintenance Procedure for Case 1 (Cleanable Surface Dirt)

Materials:

- Cleaning cloth
- Water
- Alcohol (97%) or other non-corrosive cleaning agents

Image	Steps
	<ul style="list-style-type: none"> ● Use a cloth (or other wiping tool) dampened with water to clean the dirty surface areas. ● If water alone is not sufficient, use 97% alcohol to clean the surface until the cleanliness is acceptable. (Alternatively, a commonly used non-corrosive cleaner in the local region may be used.)

Maintenance Procedure for Case 2 (Surface Dirt with Paint Scratches or Damage)

Image	Steps
	1. Use sandpaper to polish the scratched or rough paint areas to make the surface smooth.
	2. Use a cloth dampened with water or 97% alcohol to wipe the damaged area and remove surface stains.
	3. After the surface is completely dry, use a soft brush to apply touch-up paint to the scratched area to ensure the paint is applied evenly and consistently.

Maintenance Procedure for Case 3 (Exposed Substrate due to Primer Damage)

Materials:

- Sandpaper
- Cleaning cloth
- Water
- Alcohol (97%)
- Zinc-rich primer
- Soft brush
- Topcoat paint in RAL 9003 color





Image	Steps
	1. Use sandpaper to grind the damaged paint area, removing rust and burrs, and smoothing the surface.

Image	Steps
	<p>2. Use a cloth dampened with water or 97% alcohol to wipe the damaged area and remove dust and debris.</p>
	<p>3. Once the surface is dry, apply zinc-rich primer to the exposed substrate using a spray method to ensure full coverage of the bare metal.</p>
	<p>4. After the primer has dried completely, use a soft brush to apply topcoat paint to the damaged area to ensure the paint is applied evenly.</p>

Inspect the protective coating on the surface of the energy storage integrated system for signs of peeling, flaking, or paint loss.

If any such issues are found, carry out repair work promptly.

It is recommended to recoat the entire exterior of the energy storage integrated system with a specialized protective paint every five years.

C Emergency Handling

If an accident (including but not limited to the following) occurs on the site, ensure the safety of onsite personnel first and contact Dunext's service engineers.

Battery Falling or Strong Impact

- If a battery has obvious damage or abnormal odor, smoke, or fire occurs, evacuate the personnel immediately, call emergency services, and contact the professionals. The professionals shall use fire extinguishing facilities to extinguish the fire under safety protection.
- If the appearance is not deformed or damaged, and there is no obvious abnormal odor, smoke, or fire, ensure safety and perform the following operations:
 - Warehouse: Evacuate personnel, transfer the battery to an open and safe place by professionals using mechanical tools, and contact Dunext's service engineers. Leave the battery for an hour and ensure that the battery temperature is within the room temperature range (tolerance: $\pm 10^{\circ}\text{C}$) before handling.
 - ESS onsite: Evacuate personnel, close the doors of the ESS, transfer the battery to an open and safe place by professionals using mechanical tools, and contact Dunext's service engineers. Leave the battery for an hour before handling.

Flood

- Power off the system if it is safe to do so.
- If any part of the batteries is submerged in water, do not touch the batteries to avoid electric shock.
- Do not use batteries that have been soaked in water. Contact a battery recycling company for disposal.

Fire

- If a fire occurs, power off the system if it is safe to do so.
- Extinguish the fire with carbon dioxide, FM-200 or ABC dry powder fire extinguishers.

- Ask firefighters to avoid contact with high-voltage components during firefighting to prevent the risk of electric shock.
- Overheating may cause battery deformation, faults, and leakage of corrosive electrolytes or toxic gases. Use respiratory protective equipment and keep a safe distance from the batteries to prevent skin irritation and chemical burns

Extinguishant Release or Fire

- Suggestions for onsite O&M personnel:
 - a. When a fire occurs, evacuate from the building or equipment area, press the fire alarm bell, and immediately call the fire emergency service. Notify the professional firefighters and provide them with relevant product information, including but not limited to battery pack types, ESS capacity, and battery pack location and distribution.
 - b. Do not enter the affected building or equipment area under any circumstances, and do not open the doors of the ESS. Isolate and monitor the site. Keep irrelevant personnel away from the site.
 - c. After calling the fire emergency service, remotely power off the system (e.g. intelligent prefabricated substation, intelligent energy storage controller, auxiliary power supply device, combiner box power supply) while ensuring your own safety.
 - d. After professional firefighters arrive, provide relevant product information, including but not limited to battery pack types, ESS capacity, battery pack location and distribution, and user manuals.
 - e. After the fire is extinguished, the site must be handled by professionals in accordance with local laws and regulations. Do not open the doors of the ESS without permission.
 - f. Post-disaster product maintenance: Contact Dunext's service engineers for evaluation.
- Suggestions for professional firefighters:
 - a. For product information, see the information provided by O&M personnel, including but not limited to battery pack types, ESS capacity, battery pack location and distribution, and user manuals.
 - b. Do not open the doors of the ESS before it is deemed safe by professionals.
 - c. Follow local firefighting regulations.
 - d. When a fire occurs, prevent the fire from spreading to nearby ESSs.

D How to Recycle Used Batteries

**NOTE!**

Dunext does not provide battery recycling services. Customers are responsible for contacting local recycling agencies to properly dispose of used batteries. If there are no local agencies available, it is recommended to contact nearby national recycling organizations for assistance.

1. Classification and Collection

This is the first step in battery recycling: sorting batteries by type. Batteries can be classified into:

- Primary batteries (e.g., dry cells, lithium batteries)
- Secondary batteries (e.g., nickel-metal hydride, lead-acid batteries)

Since different battery types contain different materials and require different disposal methods, proper classification enhances recycling efficiency and effectiveness. Dedicated recycling bins should be set up in public areas such as communities, schools, and shopping malls for convenient disposal.

2. Transportation

Collected batteries must be transported to recycling facilities using specialized vehicles. Proper packaging must be used to ensure safe transportation and to prevent incidents such as short-circuiting or leakage.

- For lithium batteries prone to short-circuiting, insulated packaging is required.
- For lead-acid batteries that may leak, containers must be well-sealed to prevent spillage.

3. Disassembly

Upon arrival at the recycling facility, the batteries undergo disassembly, including the following steps:

- Discharging to eliminate any residual energy (especially important for lithium batteries, which may catch fire or explode if disassembled with remaining charge)
- Removing the battery casing
- Extracting internal components, such as metals, plastics, and electrolytes

4. Materials Recovery

The materials obtained from disassembly are further processed for recovery:

- 1) Valuable metals (e.g., cobalt, lithium, nickel) and plastics are recovered through methods such as:
 - Hydrometallurgical processing: dissolving and precipitating valuable metals via chemical treatment
 - Pyrometallurgical processing: using high temperatures to smelt and separate metals
 - Mechanical processing: crushing and sieving to preliminarily separate materials
- 2) Hazardous substances (e.g., heavy metals, electrolytes) are treated to neutralize environmental risks.

5. Resource Utilization

Recovered materials can be reused to manufacture new battery products, achieving closed-loop recycling.

Some materials may also be used in other industries, such as construction materials or fertilizers.

For example:

- Recovered cobalt and lithium can be reused as electrode materials in new batteries.
- Recycled plastics can be processed and used in the production of other plastic goods.

6. Harmless Treatment

Waste batteries and residual hazardous substances that cannot be recycled must undergo harmless (non-toxic) treatment, including:

- Solidification
- Stabilization
- Landfilling, under strict safety protocols

For example, waste batteries containing mercury or cadmium can be encapsulated in stable materials and safely buried to prevent heavy metal contamination of the environment.

E Abbreviations

Abbreviation	Description
BESS	Battery energy storage system
BMS	Battery management system
EMS	Energy management system
SOC	State of charge
SOH	State of health
AC	Alternating current
DC	Direct current
PCS	Power conversion system
DOD	Depth of discharge
MPPT	Maximum power point tracking



Innovate for a Green Future

Dunext Technology Suzhou Co., Ltd.

✉ service@dunext.com

🌐 www.dunext.com