

## Manufacturer's CLS Product Information

This form is available in a Microsoft Word version from the ENA's website.

### G100/2 - Form B - Compliance Verification Report for Customer Export or Import Limitation Schemes

This form shall be used by the **Manufacturer** to demonstrate and declare compliance with the requirements of EREC G100. The form can be used in a variety of ways as detailed below:

#### 1. For Fully Type Tested status

The **Manufacturer** can use this form to obtain **Fully Type Tested** status for a **CLS** by registering this completed form with the Energy Networks Association (ENA) Type Test Register.

#### 2. To obtain Type Tested status for a product

The **Manufacturer** can use this form to obtain **Type Tested** status for one or more **Components** which are used in a **CLS** by registering this form with the relevant parts completed with the Energy Networks Association (ENA) Type Test Register.

#### 3. One-off Installation

The **Installer** can use this form to confirm that the **CLS** has been tested to satisfy the requirements of this EREC G100. This form shall be submitted to the **DNO** before commissioning.

A combination of (2) and (3) can be used as required, together with Form C where compliance of the **CLS** is to be demonstrated on site.

Note:

If the **CLS** is **Fully Type Tested** and registered with the Energy Networks Association (ENA) Type Test Register, Form C shall include the **Manufacturer's** reference number (the Type Test Register system reference), and this form does not need to be submitted.

Where the **CLS** is not registered with the ENA Type Test Register or is not **Fully Type Tested** this form (all or in parts as applicable) shall be completed and provided to the **DNO**, to confirm that the **CLS** has been tested to satisfy all or part of the requirements of this EREC G100.

<b>CLS Designation</b>		Meter with inverter system Meter GMK110 ---- Inverter GW3600M-ES-20, GW3600-ES-20, GW5000M-ES-20, GW5000-ES-20, GW6000M-ES-20, GW6000-ES-20 Meter GMK110D ---- Inverter GW3600-SBP-20, GW5000-SBP-20	
<b>Manufacturer name</b>		GoodWe Technologies Co., Ltd.	
Address		No.90 Zijin Rd., New District, Suzhou, 215011, P.R. China	
Tel	+86 512 6239 7998	Web site	<a href="https://en.goodwe.com/">https://en.goodwe.com/</a>
E:mail	service@goodwe.com		
<b>Installer's name</b>			
Address			
Tel		Web site	
E:mail			

Export/Import capabilities			
Export	Y	Import	Not Applicable
Description of Operation			
<p>EREC G100 section 4.2 requires a description of the <b>CLS</b>, and schematic diagram, to be provided to the <b>Customer</b>. Please provide that description and the diagram here.</p>			
<p>CLS is composed of inverter and meter, in which the functions of the Device Control Unit(s) and Control Unit are provided by the inverter, and the function of Measurement Transducer is provided by the meter.</p> <p>Firstly, the corresponding limiting current of Export Limitation is set through Solar Go APP, then CLS collects the current and voltage at the grid through the meter, and feeds them back to the inverter, which carries out Export Limitation control after judging.</p> <p>Export Limitation schemes as follows:</p> <p>PV-Grid mode of inverter GW3600M-ES-20, GW3600-ES-20, GW5000M-ES-20, GW5000-ES-20, GW6000M-ES-20, GW6000-ES-20:</p>			
<p>Battery-Grid mode of inverter GW3600M-ES-20, GW3600-ES-20, GW5000M-ES-20, GW5000-ES-20, GW6000M-ES-20, GW6000-ES-20:</p>			

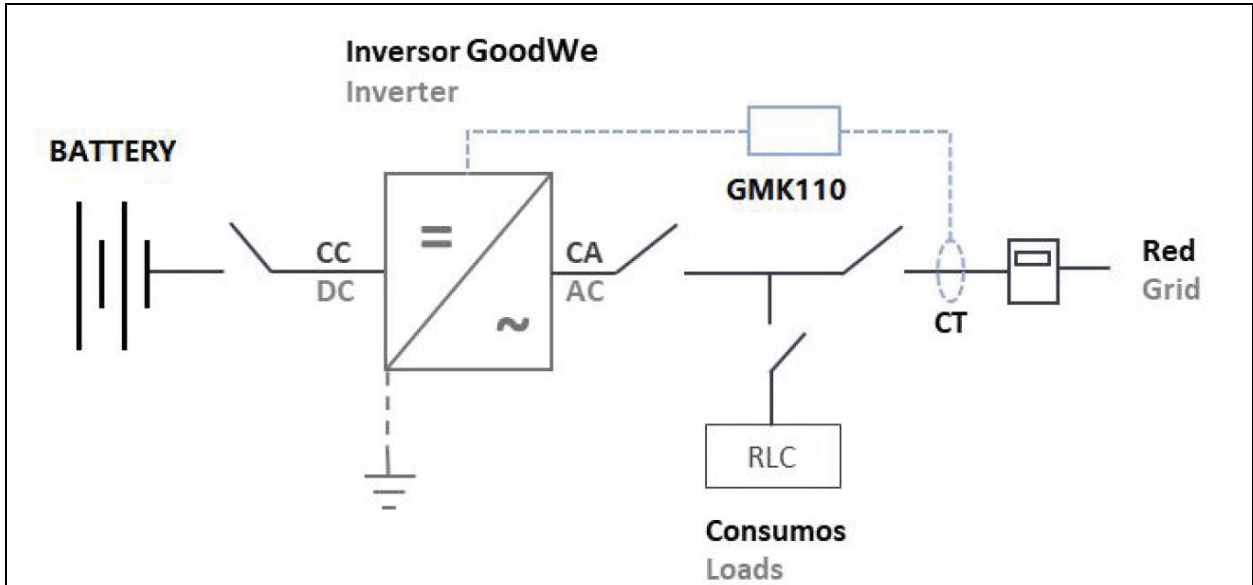

Battery-Grid mode of inverter GW3600-SBP-20, GW5000-SBP-20:

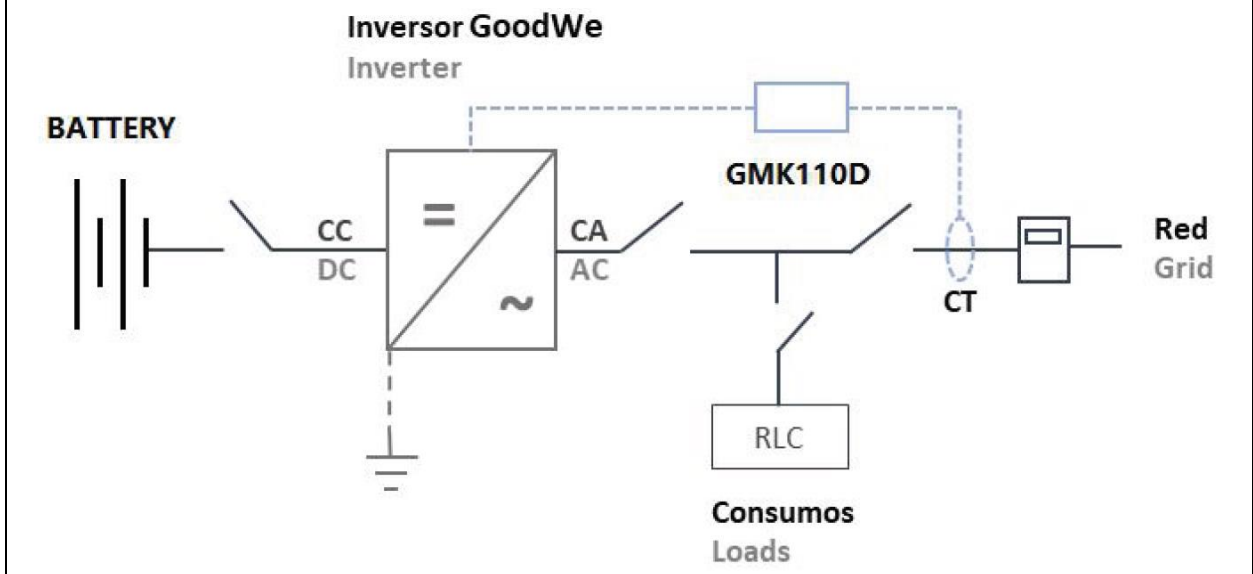

### Communications Media

Document the provisions made for the use of various communication media, and both the inherent characteristics and the design steps made to ensure security and reliability.

The CLS scheme is composed of an inverter and a meter (GMK110 or GMK110D).

The meter (GMK110 or GMK110D) as a measurement transducer is used to collect voltage and current of the power grid, and then feeds back the sampling results to the Control Units which are built into the inverter. The Control Units will make Export Limitation response according to the voltage and current of the grid.

Internal Communications Media:

The inverter and the meter are connected by RS485 port, and communicate with each other through Modbus RTU communication protocol, which is an industry-recognized security and reliability protocol.

External Communications Media:

Inverter external communication is realized through SolarGo Mobile App. The Control Units which are built into the inverter will feed back the states of Export Limitation to SolarGo Mobile App. And the states of Export Limitation can be displayed on SolarGo Mobile App:

State 1-Normal Operation

State 2 -- Occasional Excursion

State 3 -- Failed State.

### Cyber Security

Confirm that the **Manufacturer** or **Installer** of the **CLS** has provided a statement describing how the **CLS** has been designed to comply with cyber security requirements, as detailed in section 4.7.

CLS has two communication mode of Export Limitation---RS485 and SolarGo Mobile App.

For details, please refer to "GoodWe declaration about cyber-security".

### Power Quality Requirements

Where the **CLS** includes the power electronics that controls generation or loads (as opposed to the power electronics being included in **Devices** that are subject to their own power quality compliance requirements) please submit the harmonic and disturbance information here as required by EREC G5 and EREC P28.

Please refer to the power quality data in G99 report.

### Fail Safe

**CLS** internal failure: please submit here the description of the internal **Fail Safe** design and operation. Please also document how it has been demonstrated, including the non-volatile recording of times and numbers of state 2 operations, and confirm the overall response of the **CLS** to this internal failure.

There are two DSP of CLS control. When an internal failure occurs in the CLS, one DSP will fail, and the other DSP will immediately respond and move the CLS from current state to state 3. At the same time, it will save the real-time data of timer and counter to flash. Data will be read from flash when powered on again.

the non-volatile recording of times and numbers of state 2 operations are as follows:

A single excursion into state 2 operation that persists for more than 1 minute

- There are more than three excursions (each of more than 10s and less than 1 minute into state 2 operation in any 24 hour period;
- The time between any two consecutive excursions into state 2 operation of greater than 10s is 10 minutes or less (measured from the time of re-entry into state 1 operation from state 2 operation following the first excursion)

The CLS shall detect any internal failure and move its operation into state 3 immediately within 5s after detecting such a failure

Design schematic diagram of inverter (GW3600M-ES-20, GW3600-ES-20, GW5000M-ES-20, GW5000-ES-20, GW6000M-ES-20, GW6000-ES-20) as follows:

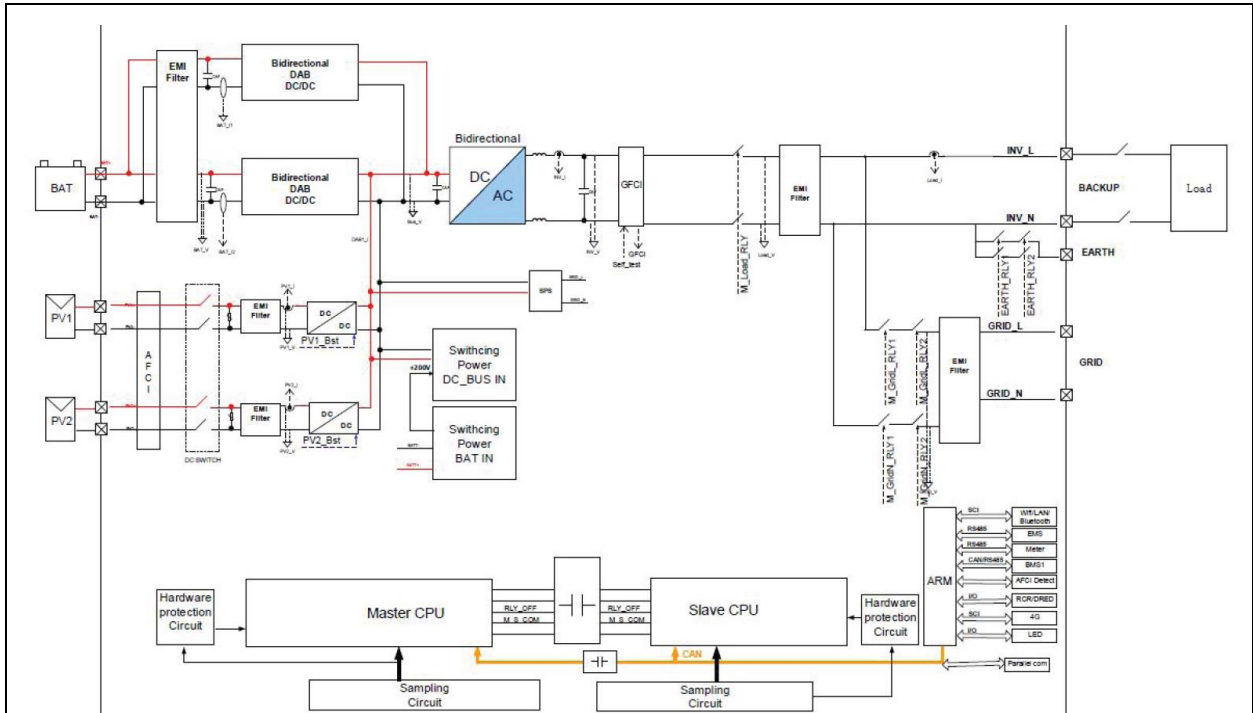

Design schematic diagram of inverter (GW3600-SBP-20, GW5000-SBP-20) as follows:

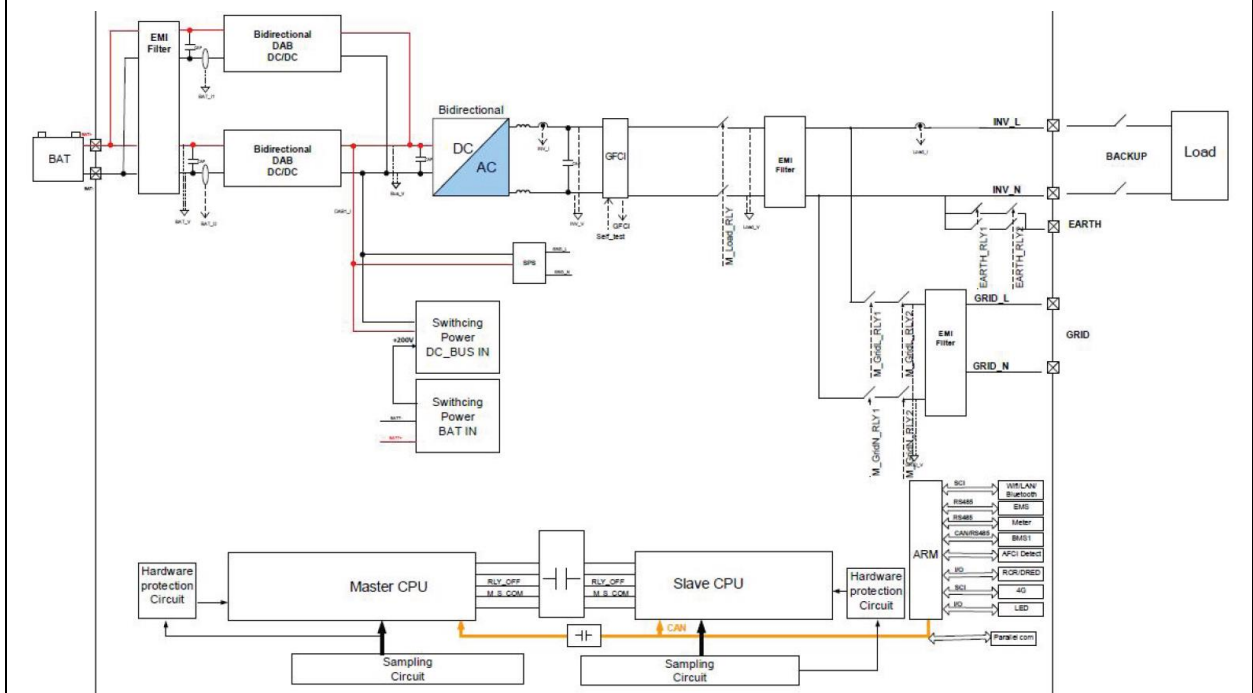

Communication and power supply failures between **Components** and **Devices**. Please document here compliance with EREC G100 section 5.5.

Component/Device number/description	Communication failure test	Power supply failure test
1.Connection Point Component (CT)	NA	After removing power supply , CLS enters state 3 operation in 3s

2.Principle CLS Component(s)	NA	After removing power supply , CLS enters state 3 operation in 5s
3.Components controlling generation Devices (Meter)	NA	After removing power supply , CLS enters state 3 operation in 2s
4.Components controlling storage Devices (Meter)	NA	After removing power supply , CLS enters state 3 operation in 5s
5.Components controlling load Devices	NA	NA
6.Communication controller (RS485)	NA	After removing power supply , CLS enters state 3 operation in 5s
7.Communication between Components (between Inverter and Meter)	After interrupting communication, CLS enters state 3 operation in 3s	NA
8.Where applicable communication between Components and Devices	NA	NA
9.CLS system	NA	When DSP chip, ARM chip or opt coupler is in a single fault, CLS can report the corresponding fault, and CLS enters state 3 operation in 5s

### Operational Tests

In accordance with EREC G100 section 5.6 undertake the tests A and B to confirm correct operation in state 1 and state 2, that transition into state 3 occurs as required, and that behaviour in state 3 is also as required.

#### Test A

Nominal Export Limit (for type tests this will be at maximum, minimum and one intermediate setting) in Amp:						13.0A
Nominal Import Limit (for type tests this will be at maximum, minimum and one intermediate setting) in Amp:						NA
No	Starting level	Step value	CLS registers change in level?	CLS and/or Component and/or Device initiates correct response of $\geq 5\%$ ?	Duration of step in test	Correct state 1/ state 2 operation
1	Export I=12.17A	I=13.65A	$\Delta I=1.17A$	Y	11s	state 1
2	Export I=12.54A	I=14.51A	$\Delta I=1.99A$	Y	5s	state 1

3	Export I=12.55A	I=15.73A	$\Delta I=3.19A$	Y	6s	state 1
4	NA	NA	NA	NA	NA	NA
5	NA	NA	NA	NA	NA	NA
6	NA	NA	NA	NA	NA	NA
Test B						
Nominal Export Limit:						13.0A
Nominal Import Limit						NA
No	Starting level	Step value	CLS registers change in level?	CLS and/or Component and/or Device initiates correct response of $\geq 5\%$ ?	Duration of step in test	Correct state 3 operation
7	Export I=12.33A	I=14.11A	$\Delta I=0.31A$	Y	90s	state 3
8	NA	NA	NA	NA	NA	NA

### State 3 Reset

These tests are to demonstrate compliance with section EREC G100 4.5.2.

Please document how the reset from state 3 to state 1 has been demonstrated. Please include how the reset is achieved.

Please confirm that for **CLSs** to be installed in **Domestic installations** three (3) resets causes lockout or that for non-domestic installations lockout can only be reset after four hours. Please explain how lockout is reset.

After a fault occurs, CLS enters state 3. Within three times, CLS can be restored to state 1 by automatically restarting. After three times, CLS is locked in state 3. After an electrician is sent to troubleshoot the problem, CLS can be restored to state 1 by manually re-selecting the safety country.