

# Quick Installation Guide

## Energy Management Unit

EMU200A



# 1 Unpacking and Inspection

Check the package and remove the internal accessories.

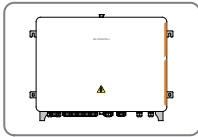

A

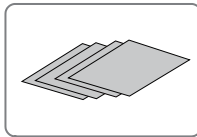

B

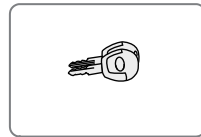

C

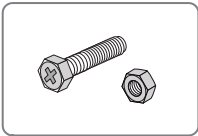

D

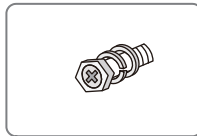

E

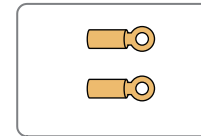

F

No.	Name	Sum
A	EMU200A	1
B	Documents, including certificate, warranty card, delivery inspection report, quick installation instruction, etc.	1
C	Keys	4
D	M10x45 bolt assembly	4
E	M6X12 bolt	1
F	OT terminal	1

## 2 Networking Scenarios

EMU200A is equipped with a Logger4000 inside, which EMU200A can be applied to various networking scenarios. It can access the inverter, box-type transformer, meteo station and meter in the PV power generation system through RS485 bus, and can also access the string inverter with PLC function produced by SUNGROW through PLC bus.

- EMU200A can transmit the collected device data to the background plant controller, such as Insight and SCADA, through the core switch.
- EMU200A can also transmit the collected device data directly to iSolarCloud through the 4G router.

## 2.1 Connected to background plant controller through a core switch

- Ring networking

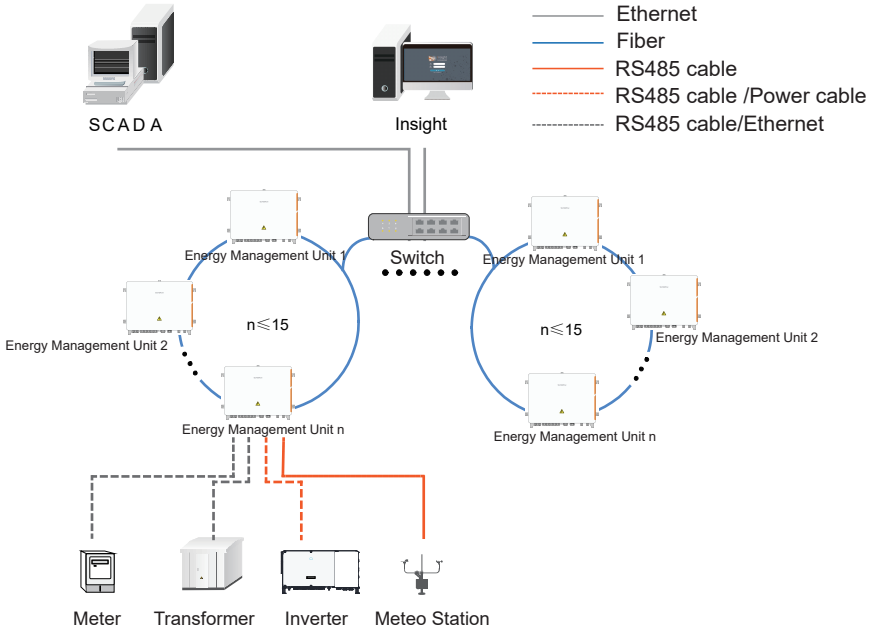

- Star networking

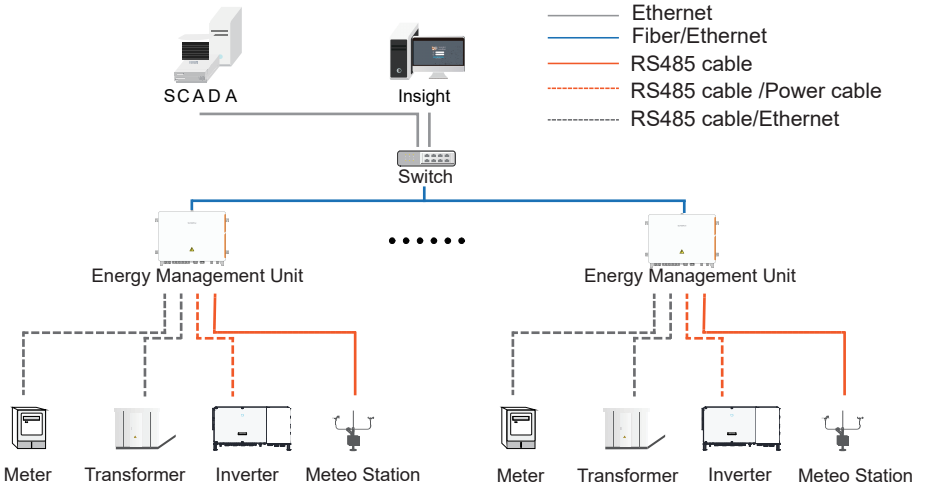

## 2.2 Connection through Router

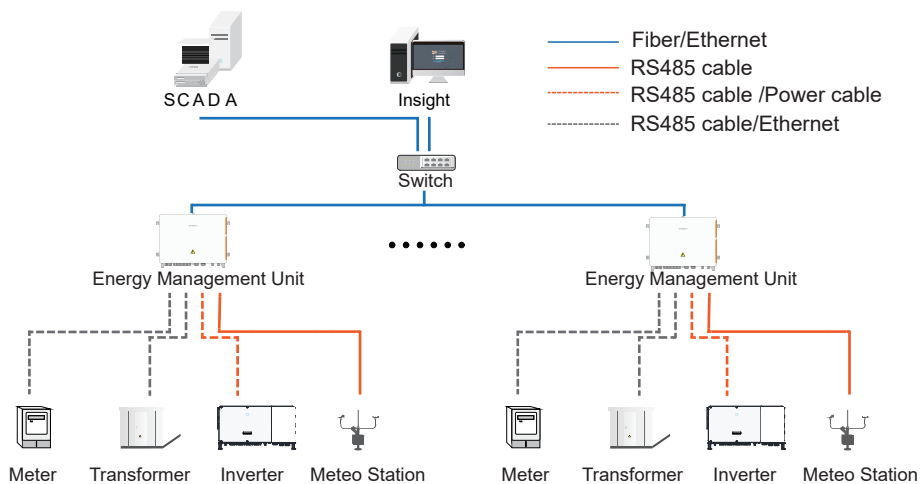

## 3 Installation Tools

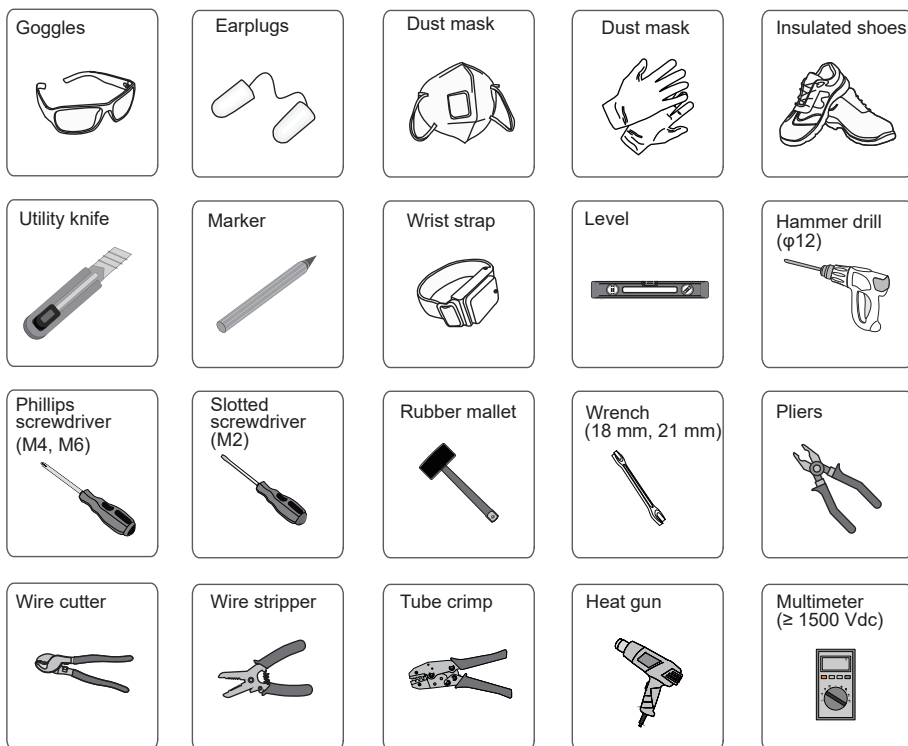

# 4 Mechanical Installation

## 4.1 Location Requirements

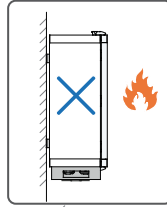
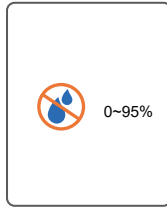
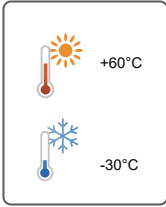

### ⚠ NOTICE

- If the ambient temperature around the device exceeds 50°C and the solar irradiance is greater than 1000 W/m<sup>2</sup>, the device must be installed in a sheltered area or fitted with a sunshade to avoid internal overheating caused by direct sunlight. When the device is installed indoors, the ambient temperature around the device must not exceed 60°C. Exceeding this limit may lead to internal overheating. (Ambient temperature around the device refers to the average temperature measured approximately 1 meter from the device.)
- Keep the device away from heat sources. Do not install it near heat sources such as transformers, hot air outlets, etc. Maintain a minimum clearance of at least 1 meter from such heat sources.

## 4.2 Installation Method

The installation dimensions of mounting ears on the back of the device are shown in the following figure (unit: mm).

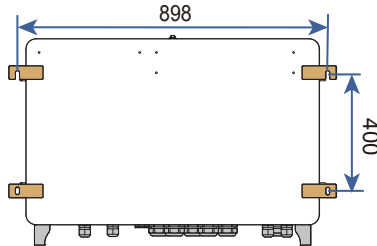

### 4.2.1 Wall Mounting

step1: Mark the hole locations on the installation wall . Drill holes on the marked locations.

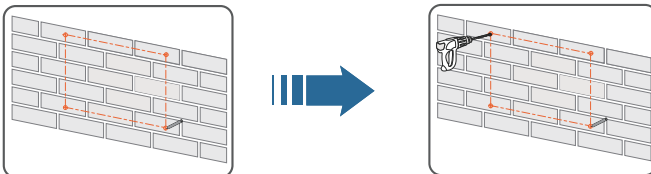

step2: Place the M10X45 expansion sleeve(not included in the scope of delivery) into the hole, and tap it with a rubber hammer. Make it completely embedded in the wall.

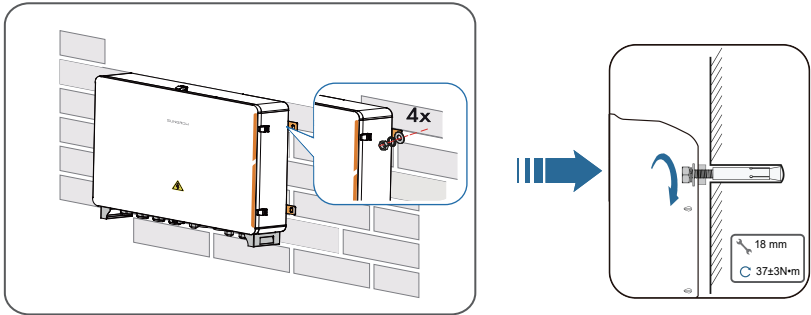

#### 4.2.2 Bracket Mounting

step1: Mark the hole locations on the installation wall . Drill holes on the marked locations.

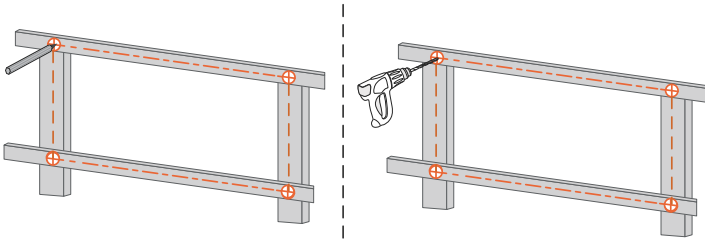

step2: Fasten the device on the brackets in the order of M10x45 bolt, mounting ear, mounting bracket.

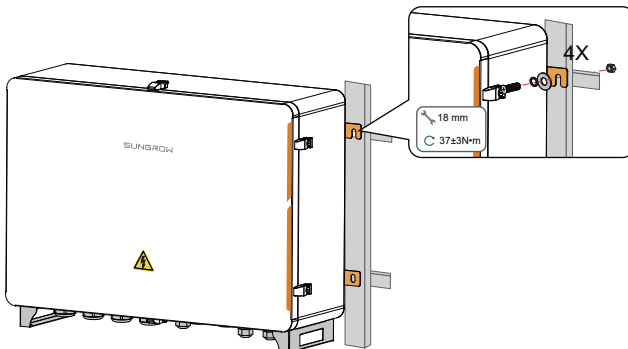

### 4.2.3 Ground Mounting

step1: Secure the installation holes in bottom of the device to the foundation , and the bolts used are M10.

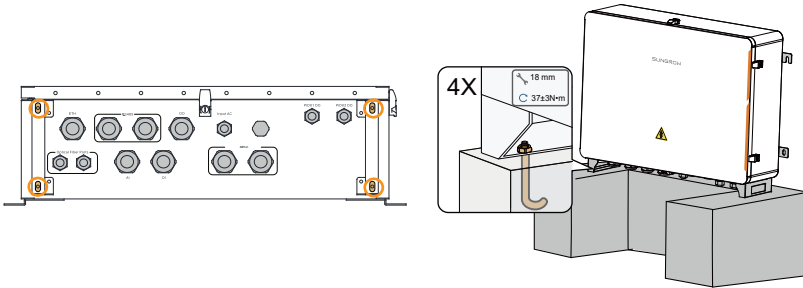

- To avoid excessive bending of cables, it is recommended that the bottom of EMU200A be 30 cm from the ground.

### 4.3 Installing IO Modules (Optional)

Before installing the IO module, set the communication address for the I/O module according to the user manual.

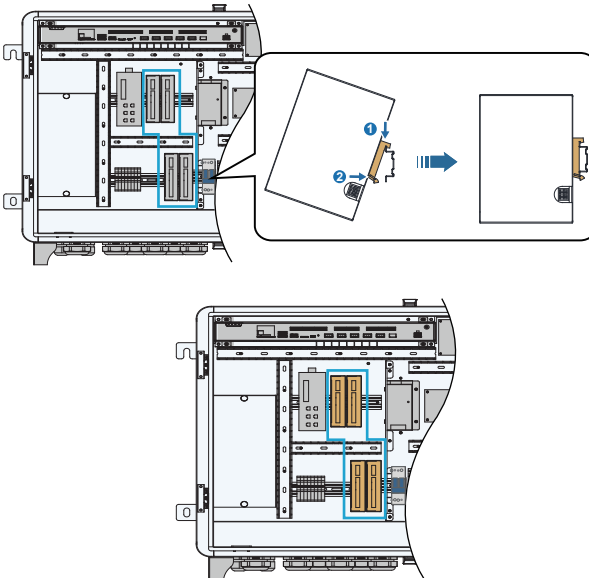

## 5 Electrical Connection

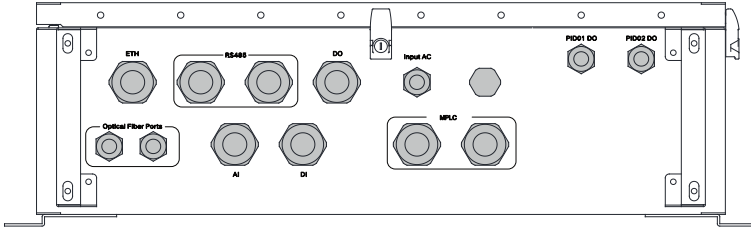

Mark	Description
ETH	Waterproof terminals for Ethernet communication cables
RS485	Waterproof terminals for RS485 communication cables
DO	Waterproof terminals for dry contact output cables
AI	Waterproof terminals for analog input cables
DI	Waterproof terminals for dry contact input cables
Optical Fiber Ports	Waterproof terminals for optical fibers
MPLC	Waterproof terminal for PLC communication cables
Input AC	Without anti-PID module: Waterproof terminal for AC 100Vac–277Vac power cables With anti-PID module: Waterproof terminal for AC 198Vac–242Vac power cables
PID01 DO	Waterproof terminal for PID dry contact output
PID02 DO	Waterproof terminal for PID dry contact output
	Grounding point, on the right side of the device

### 5.1 Preparation Before Connection

Note:

Disconnect the upstream input switch of the device, and turn the power switch inside the device to the "OFF" position to ensure the device is voltage-free.

Remove the protective cover inside the cabinet.

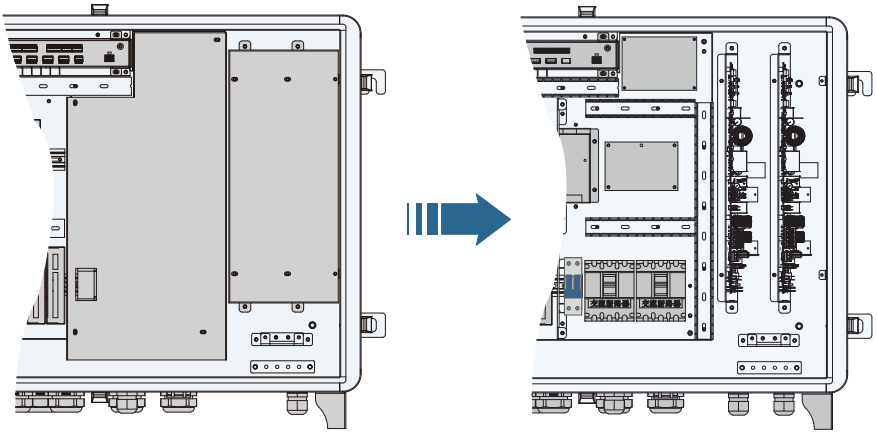

## 5.2 Grounding

- Prepare the grounding cable.

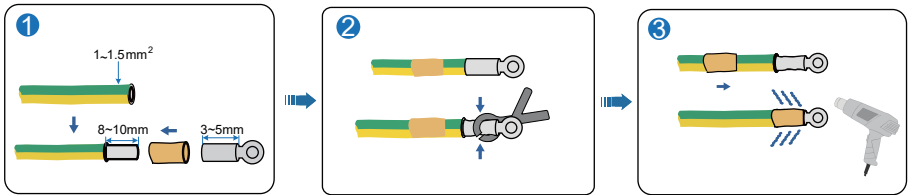

- Cooper bar grounding

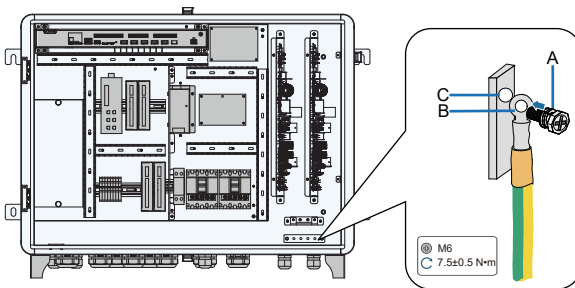

Item	Definition
A	M6x12 bolt
B	OT terminal
C	Grounding hole

• PE Point Grounding

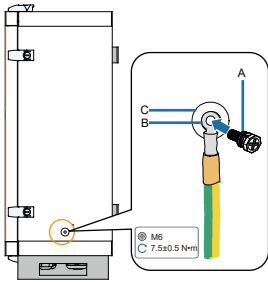

Item	Definition
A	M6 x 12 bolt assembly
B	OT terminal
C	Grounding hole

5.3 RS485

step1: Stripping Cables

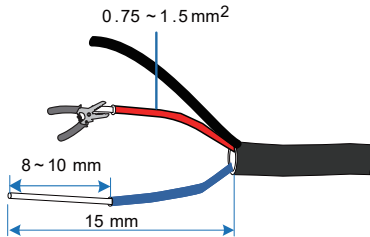

step2: Crimp the wiring terminal.

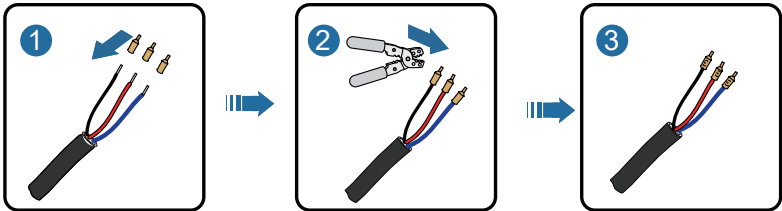

step3: Connecting Methods

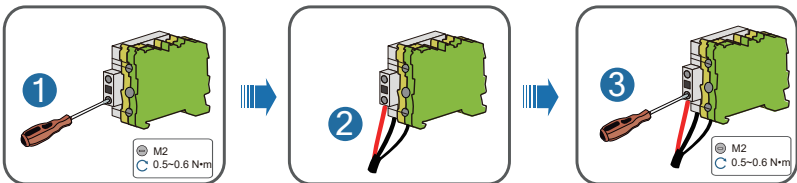

## 5.4 Power Supply Connection

step1: Stripping Cables

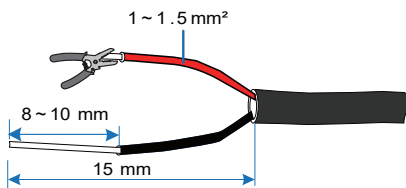

step2: Crimp the wiring terminal.

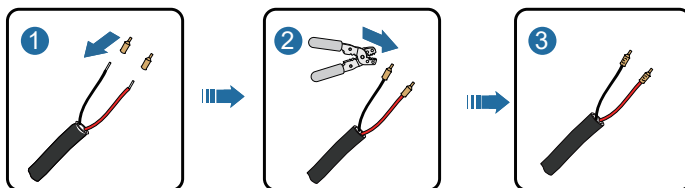

step3: Connecting Methods

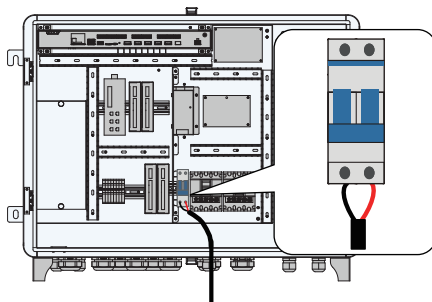

## 5.5 PLC Port Connection

step1: Stripping Cables

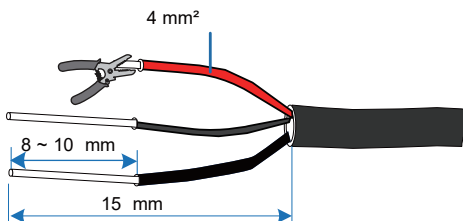

step2: Crimp the wiring terminal.

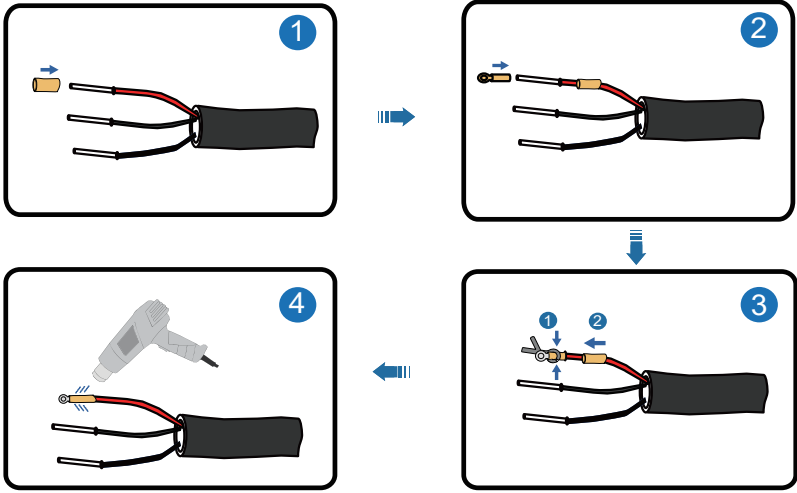

step3: Connecting Methods

- Three-phase three-wire connection

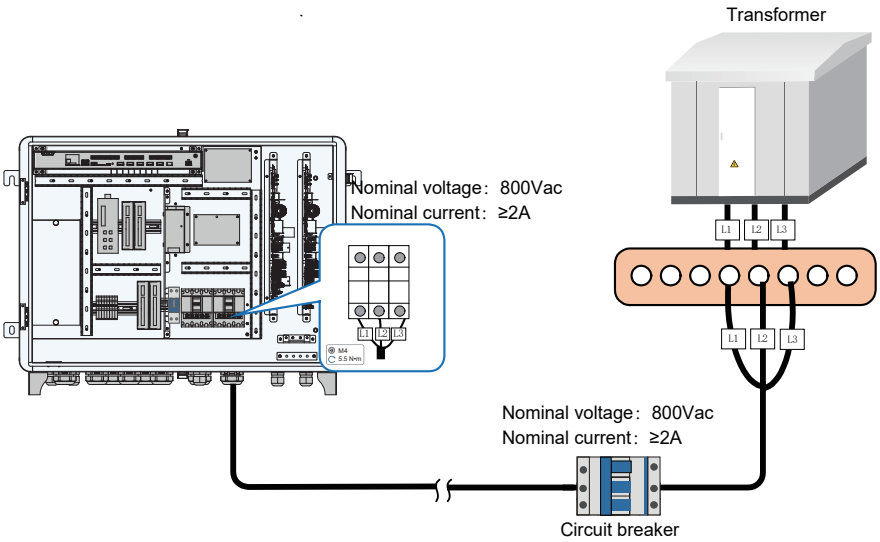

## ⚠ NOTICE

- After wiring, tighten the waterproof terminals, and seal the cable gaps with fireproof mud to prevent moisture from affecting the service life of the EMU200A.

### 5.6 PID Dry Contact Connection (Optional)

Step1: Lead the cable through the “PID01 DO” / “PID02 DO” waterproof terminal at the bottom of EMU200A, and use a wire stripper to strip off the protective layer.

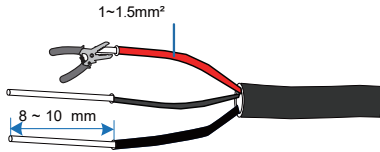

Step2: Install the cord-end terminal and press them with crimping pliers.

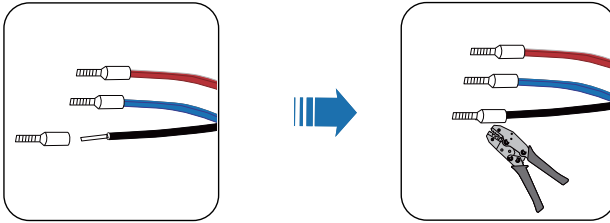

Step3: Unplug the terminals from the COM, NC, and NO interfaces on the PID module. Crimp the terminals respectively.

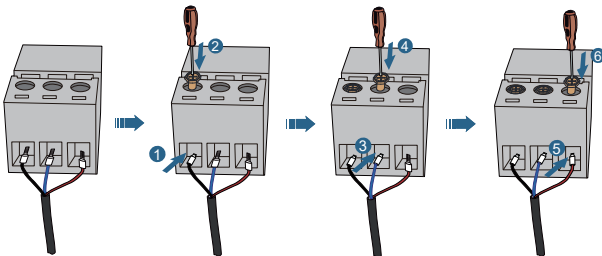

Step4: Connect the crimped terminals to the PID module respectively.

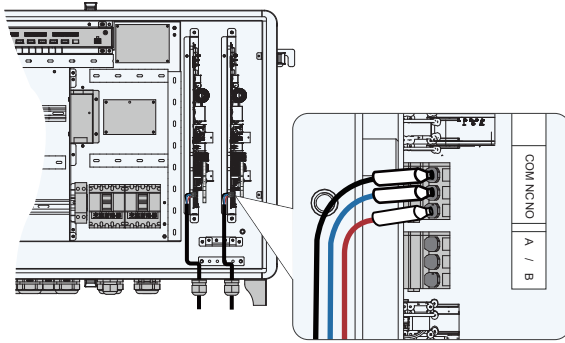

Step5: Gently pull cables to ensure that they are connected firmly, and secure the nut.

Step6: Tighten the "PID01 DO" / "PID02 DO"waterproof terminal at the bottom of the EMU200A.

## 6 Electrical Connection

### 6.1 Inspection Before Commissioning

No.	Inspection item
1	All cables are connected correctly and firmly.
2	The phase sequence of all cables is correct.
3	The internal and external grounding points of the device are reliably grounded.

### 6.2 Commissioning Steps

#### Power-on Operations

No.	Inspection item
1	Connect the internal fuse of EMU200A.
2	Connect the control switch of AC power supply.
3	Check whether the switch and 24V switch-mode power supply operate normally.
4	Observe running indicators of Logger4000. If the PWR indicator is steady on, RUN indicator flashing, WLAN indicator steady on and the FAULT indicator off,the EMU200A runs normally.
5	Connect the transformer-side circuit breaker.
6	Please lock the case and keep the key properly after commissioning.

## Logger Commissioning

No.	Inspection item
1	<ul style="list-style-type: none"> <li>The EMU200A has an internal switch: Connect PC to the Ethernet port of the switch inside EMU200A by using a network cable. The default IP address of Ethernet ports is 12.12.12.12, and the virtual IP address is 14.14.14.14.</li> <li>The EMU200A has no internal switch: Connect the PC to the Ethernet port of Logger4000 inside the EMU200A using a network cable. The IP address and virtual address of Ethernet port ETH1 are 12.12.12.12 and 15.15.15.15. The IP address and virtual address of ETH2 are 13.13.13.13 and 16.16.16.16.</li> </ul>
2	<ul style="list-style-type: none"> <li>The EMU200A has an internal switch: Configure the IP addresses of the PC and ports of the Logger on the same network segment. The IP address of the PC can be set to 12.12.12.X. The value of X ranges from 1 to 255 and cannot be 12. The subnet mask is 255.255.255.0. Or it can be set to 14.14.14.x. The value of x ranges from 1 to 255 and can not be 14. The subnet mask is 255.255.255.0.</li> <li>The EMU200A has no internal switch: Set the IP address of the PC and the Ethernet port to which the logger is connected on the same network segment. For example, the IP address of ETH1 can be set to 12.12.12. x, where x ranges from 1 to 255 and cannot be 12. The subnet mask is 255.255.255.0.</li> </ul> <p>Enter the IP address of the Ethernet port on the logger in the PC address bar to go to the default interface. Take the IP address 12.12.12.12 as an example:</p>
3	<ul style="list-style-type: none"> <li>If Network Security Mode Configuration is enabled, you must manually enter the IP address <a href="https://12.12.12.12">https://12.12.12.12</a> in the PC address bar to log in to the Logger4000 Web interface.</li> <li>If Network Security Mode Configuration is disabled, you can log in to the Logger4000 Web interface by directly entering 12.12.12.12, <a href="http://12.12.12.12">http://12.12.12.12</a>, or <a href="https://12.12.12.12">https://12.12.12.12</a> in the PC address bar.</li> </ul>
4	Configure serial port parameters.
5	Add devices.
6	Configure device IP.
7	<p>Configure iSolarCloud address if inverter data needs to be uploaded to iSolarCloud.</p> <ul style="list-style-type: none"> <li>Accessed iSolarCloud site is "Chinese Server" by default.</li> <li>In mainland Chain, set the site to "Chinese Server";</li> <li>In mainland Chain, set the site to "Chinese Server";</li> <li>In Europe, set the site to "European Server".</li> <li>In Australia, set the site to "Australian Server".</li> <li>In other regions, set the site to "International Server".</li> </ul>
8	Access the Web interface of Logger3000 and check whether the running data of string inverters manufactured by SUNGROW is normal.
9	Create power plants through iSolarCloud App, and check whether the data displayed on iSolarCloud is normal.

### Additional Description

To create power plant through iSolarCloud App, download and install the App and then proceed as follows:

1. Log into the Web interface of Logger4000 and click "About", to obtain the QR code.
  2. Scan the QR code with the App or manually input the S/N to add communication device.
- For more details, refer to Logger4000 User Manual, which can be obtained by scanning the foregoing QR code.

### PID Module Commissioning (Optional)

Step 1: Access the Web page of the logger referring to the logger commissioning section.

Step 2: Click **【Device Monitoring】** and select the PID module to be set in the device column on the left.

- Realtime values: View the real-time data such as AC insulation impedance, power output voltage, power output current, internal temperature, fault status, and alarm status.
- Initial parameter: Set parameters related to the PID module and click "Save".
- Device information: View the device model and software version.

## 7 Access to related documents

Scan the QR code

Logger4000 User Manual





More information in the QR code or  
at <http://support.sungrowpower.com>

**SUNGROW**

Sungrow Power Supply Co., Ltd.

[www.sungrowpower.com](http://www.sungrowpower.com)



QIEN M0H00215