

Installation Guide

Energy Gateway

HomeMax Single-Phase

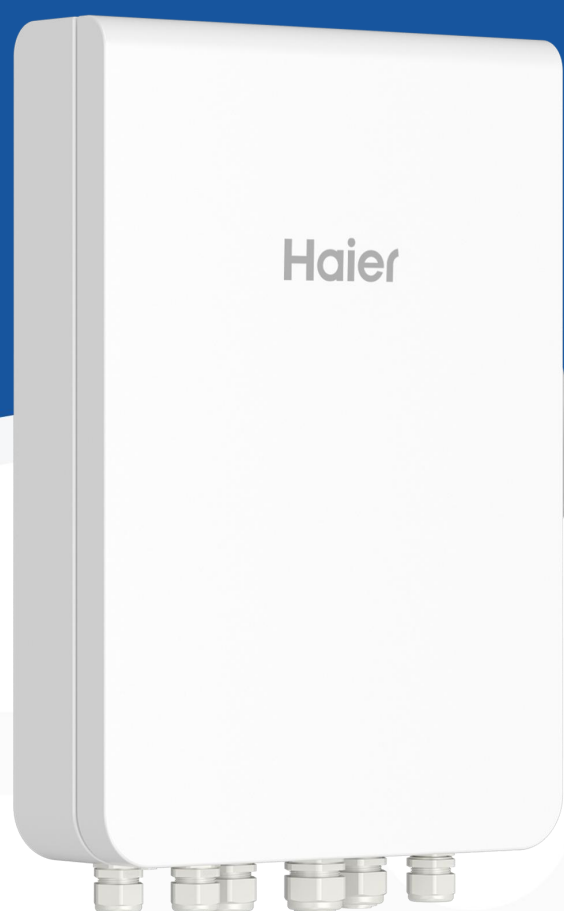

Copyright Notice

- Copyright© 2024 Qingdao NaHui Intelligent Technologies Co.,Ltd. All Rights Reserved.
- Description in this document may contain predictive statements regarding financial and operating results, product portfolio, new technology, configurations and features of product. Several factors could cause difference between actual results and those expressed or implied in the predictive statements. Therefore, description in this document is provided for reference purpose only and constitutes neither an offer nor an acceptance. Qingdao NaHui Intelligent Technology Co., Ltd. may change the information at any time without notice.

Contents

Overview	4
Chapter 1 General Requirements	5
Chapter 2 Personnel Requirements	6
Chapter 3 Handling and Transportation Requirements	6
Chapter 4 Storage Requirements	6
Chapter 5 Operating Requirements	7
5.1 Routine Requirements	7
5.2 Equipment Installation	8
5.3 Cable Connection	9
5.4 Equipment Maintenance and Replacement	9
Chapter 6 Product Description	10
6.1 Dimensions.....	10
6.2 Port Description	11
6.3 Interior view.....	11
Chapter 7 Pre-installation Check	12
Chapter 8 Site Selection Requirements	14
Chapter 9 Equipment Installation	15
Chapter 10 Cable Connection	17
10.1 Connected to Power grid.....	17
10.2 Functional ground cable.....	18
10.3 Connected to inverter	19
10.4 Connected to Distribution panel.....	18
10.5 (Optional) Connected to Controllable loads / Diesel generator.....	29
10.6 FE, RS485, DI, and DO Terminals Introduction.....	20
10.7 RJ45 Cable	20

Contents

10.8 RS485 Cable.....	22
10.9 DI, DO Cable.....	23
10.10 Internal panel installation.....	24
Chapter 11 Post-installation Check	24
Chapter 12 Equipment Power-On	25

Overview

Introduction

This document describes the precautions for installing, operating, and maintaining the Gateway.



Target readers

This document is intended for:

- Trained and qualified installation personnel
- Technical support engineer

• Sign Definition

- The following signs may be used in the document to indicate security precautions or key information. Before installation and operation, familiarize yourself with signs and their definitions.

Signs	Definition
 Danger	Danger. Failure to comply may result in death or serious personal injury.
 Warning	Warning. Failure to comply may result in minor injury or property damage.
 Caution	Caution. Failure to comply may result in equipment damage and property loss.
Tips	Important or key information, and supplementary operation tips.

Chapter 1 General Requirements

Before installing, operating, and maintaining the equipment, familiarize yourself with this document.

The "Danger", "Warning", and "Caution" items described in this manual are only supplementary to all precautions.

The Company shall not be liable for equipment damage or property loss caused by the following reasons:

- The installation environment does not meet international, national, or regional standards.
- Failure to comply with local laws, regulations, and regulations when transporting, installing, operating, or maintaining the equipment.
- The installation area does not meet the requirements of the equipment.
- Cables and tools used do not meet international, national, or regional standards.
- Damage caused by storage conditions that do not meet equipment requirements.
- Failure to follow the instructions and precautions in this document.
- Failure to handle the equipment with care or violent installation may result in equipment damage and liquid leakage and pose a risk of fire or explosion hazards.
- Failure to follow the warning labels on equipment or tools.
- Negligent, improper operation or intentional damage.
- Damage caused by the customer or the third party company changing the use of our company's equipment.
- The equipment is damaged by the failure of the customer or the third-party company to use the accessories supplied with the package and purchase and use the accessories of the same specifications for installation.
- Equipment damage caused by improper operations such as disassembling, replacing, or modifying the software code without authorization.
- Equipment damage caused by force majeure (such as war, earthquake, fire, storm, lightning, flood, debris flow, etc.).
- Damage caused by the failure of the natural environment or external power parameters to meet the standard requirements of the equipment during actual operation (for example, the actual operating temperature of the equipment is too high or too low).
- The equipment was stolen.
- The equipment is damaged after the warranty period.

Chapter 2 Personnel Requirements

The personnel responsible for installation and maintenance of the equipment must receive strict training, be familiar with local laws, regulations, and related standards, understand the structure and working principles of the power generation system, understand various safety precautions, master the correct operation methods, and possess the operation qualifications required by the local country.

Chapter 3 Handling and Transportation Requirements

- Wear personal protective equipment, such as protective gloves and safety shoes, when moving equipment.
- Select a proper transport mode based on the weight of the equipment.
- Carry the equipment in the direction specified on the package. Do not tilt or invert the equipment.
- The incline angle of the equipment belt package shall be no more than 15°, and the incline angle after unpacking shall be no more than 10°. If more than one person is moving the equipment, consider the height of the person moving the equipment to ensure stability.
- To avoid injury, lift or move the equipment slowly.
- When using a forklift, place the fork knife in the middle of the equipment, and bind the fork knife according to the actual situation. When moving, a special person should take care of it. No movement under the fork knife.
- Place the equipment according to the stacking requirements on the package.

Chapter 4 Storage Requirements

- The storage location must comply with local laws and regulations.
- Do not unpack the storage equipment.
- Do not expose the equipment to direct sunlight or to wet, dewy, dirty, rainy, flammable, explosive or corrosive environments.
- The storage location should be well protected against insects and rodents.
- When storing the equipment, place it according to the storage requirements on the package.
- During storage, periodically record the temperature and humidity of the storage environment.
 - Storage temperature: -40°C to 70°C, and 20°C to 30°C is recommended.
 - Relative humidity: 0% RH to 95% RH.
- Please follow the "first-in, first-out" principle when shipping the equipment.

Chapter 5 Operating Requirements

5.1 Routine Requirements

Danger

High voltage, danger:

- Live operation of the equipment (including but not limited to installation, wiring, replacement, etc.) is prohibited.
- Do not operate the equipment in bad weather (including but not limited to thunder, rain, snow, typhoon, etc.).
- Do not clean or soak the equipment with water, alcohol, or oil to avoid power leakage.
- Do not hit, drag, or step on the equipment.
- Check the equipment for damage before operating it. Do not perform this operation if there is any abnormality (for example, deformed appearance or strange smell).
- When operating the equipment, wear protective equipment such as insulation gloves, shoes, and safety helmets. Conductive ornaments such as metal bracelets, rings and necklaces are prohibited.
- Use insulation tools when installing and connecting cables.
- Devices that need to be grounded are permanently connected to the protection ground. When connecting cables, connect the ground cable first. Before replacement of any equipment, remove the ground cable at last.
- Before touching the terminal, measure the voltage of the contact point to ensure that there is no danger of electric shock.
- Do not drop any foreign objects into the equipment when operating it.
- If scratches appear on the equipment's surface, repair the paint in time.

5.2 Equipment Installation

Warning

When handling the equipment, be prepared to support the load in order to avoid slips and injuries.

Ladder Safety

- Do not use ladders without training or instruction.
- Do not use unqualified ladders (including but not limited to damaged, broken, deformed, and temporary ladders).
- Do not use a ladder that does not meet the load-bearing requirements.
- Use wooden or fiberglass ladders when there is a possibility of electrical work at height.
- When an extension ladder is used, the inclination of the ladder is 60° to 70°.
- When working on a ladder, do not throw objects from height.
- When working on a ladder, it is recommended that another person supervises the operation.
- Lock the door when using the ladder at the entrance of the passageway.

Drilling Safety

- Do not drill holes on the equipment.
- Wear safety goggles and protective gloves when drilling holes.
- Do not place the equipment near the drilling position to prevent debris from falling into the equipment.
- After drilling holes, clean them in time.

5.3 Cable Connection

Danger

- Before connecting cables, ensure that the equipment is not damaged.
 - Before connecting or removing cables, ensure that the front and rear switches of the equipment and its own switches are disconnected.
-
- Do not intertwine or cross cables. You are advised to bundle cables by category.
 - Do not use cables whose insulation layer is damaged, and do not have sharp edges or burrs in the holes where cables pass through.
 - Keep cables away from heat sources to prevent cable aging in a high temperature environment.
 - The lower the ambient temperature is, the more brittle the plastic cable skin will be. To prevent skin cracking during installation, install the cable at a temperature higher than 0°C and handle the cable with caution. If cables are stored in an environment below 0°C for a long time, move them to an environment above 0°C for at least 24 hours before using them.

5.4 Equipment Maintenance and Replacement

Before maintaining or replacing the equipment, power off the equipment and wait for a sufficient period of time according to the delay label on the equipment. Power on the equipment only after the fault is completely rectified or the replacement is complete.

⚠ CAUTION

- Trained or experienced electrical personnel are required to operate the equipment.
- Operators should be familiar with national/regional laws, regulations and standards, the structure and working principle of relevant systems.
- Please read carefully the operating requirements and precautions in this document and Important Notice before operating. Failure to do so may result in damage to the equipment that is not covered by the warranty.

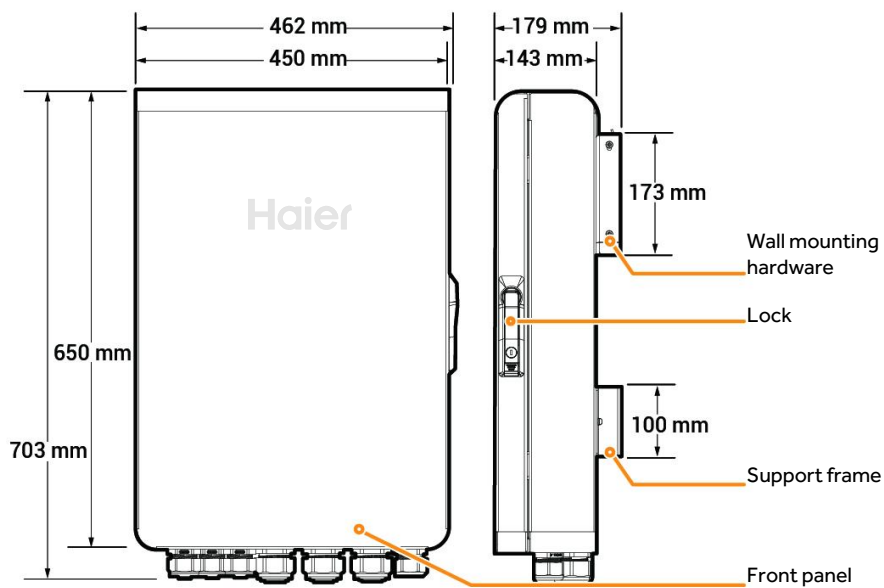
Chapter 6 Product Description**6.1 Dimensions**

6.2 Port Description

Bottom view

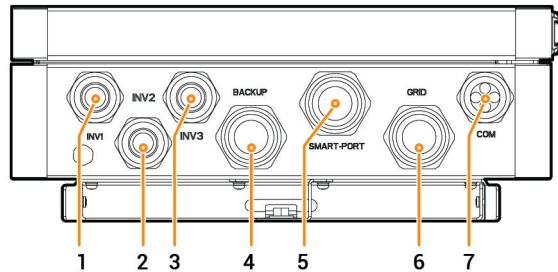

No.	Description	Marking
1	Wire-in port of inverter 1	INV1
2	Wire-in port of inverter 2	INV2
3	Wire-in port of inverter 3	INV3
4	Wire-in port of distribution panel	BACKUP
5	Wire-in port for controllable loads/diesel generator	SMART-PORT
6	Wire-in port of power grid	GRID
7	Wire-in port of communication	COM

6.3 Internal view

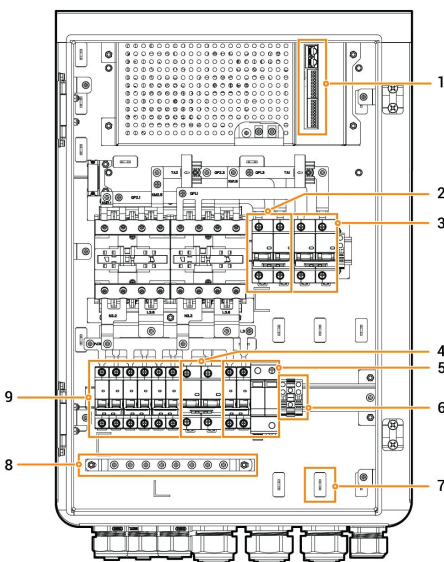

S/N	Name
1	FE, RS485, DI, and DO interfaces
2	Circuit breaker (Controllable loads/Diesel generator)
3	Circuit breaker (Power grid)
4	Circuit breaker (Distribution panel)
5	Circuit breaker + Surge protection device
6	GND
7	Cable clamp
8	Earthing bar
9	Circuit breaker (Inverters 1, 2 and 3)

Chapter 7 Pre-installation Check

- According to the packing list, check whether the components are complete and in good appearance. If any abnormality occurs, contact your sales agent in time.
- Check personal protective equipment and installation tools to ensure that they are complete; if not, please make them up.
- Check the customer-provided cable to ensure that the quantity and specifications are correct; if not, prepare again.

Protective equipment



Installation tool

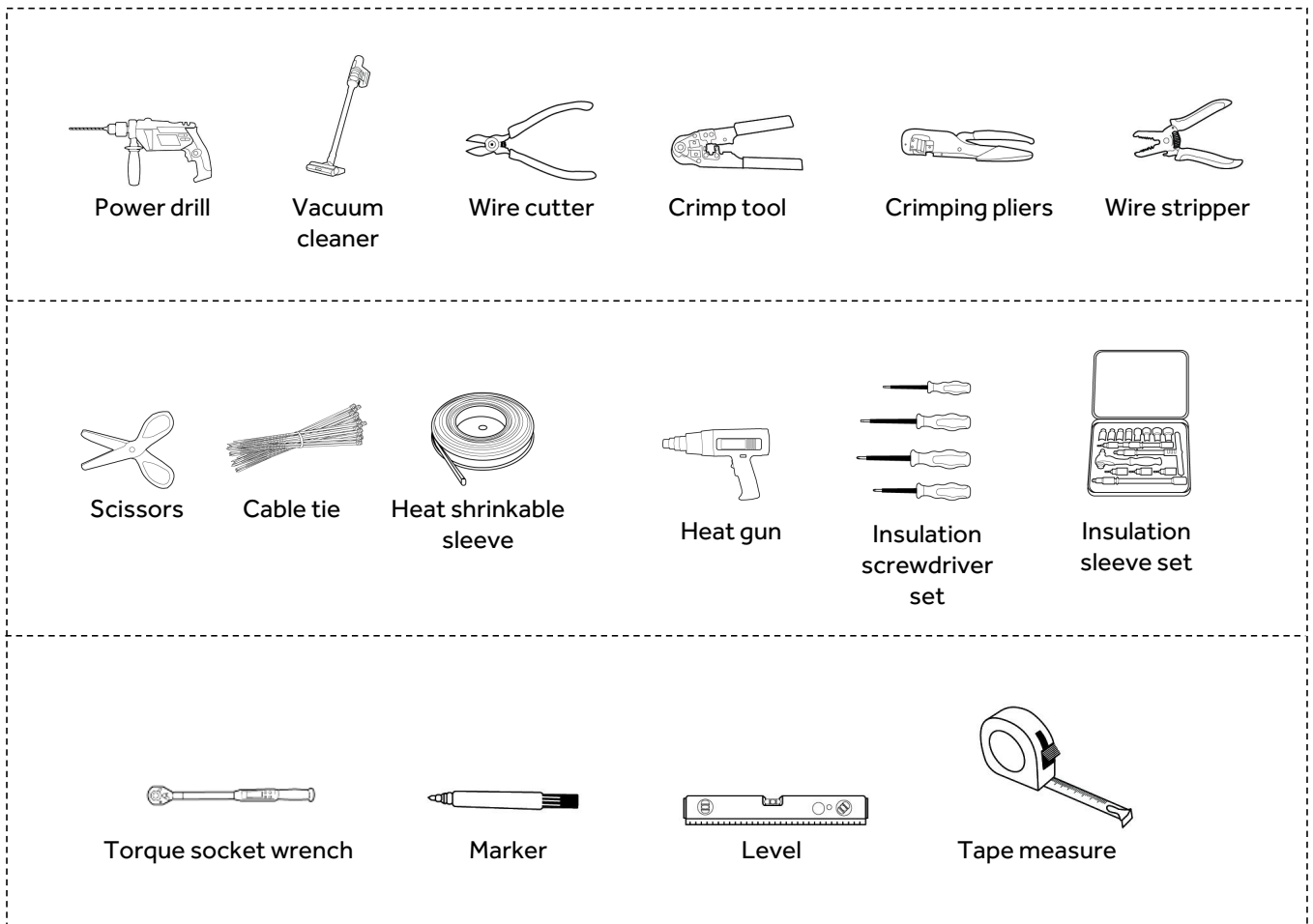

 **Caution**

- The specifications of the Installer-provided cable must comply with the cable regulations and standards of the country/region standards.

Installer-provided cable

S/N	Cable name	Recommended specifications
1	Functional ground cable	Outdoor single-conductor copper cable Cross-sectional area of core conductor: 6–10 mm ² ; Outer diameter: 5–8 mm
2	AC cable	Connected to inverter Outdoor three-core copper cable (L, N, PE) Cross-sectional area of core conductor: 4–6 mm ² ; Outer diameter: 13–21 mm
3		Connected to distribution panel Outdoor three-core copper cable (L, N, PE) Cross-sectional area of core conductor: 35–50 mm ² ; Outer diameter: 28–32 mm
4		Connected to power grid
5		Connected to controllable loads/diesel generator/ (optional) Outdoor three-core copper cable (L, N, PE) Cross-sectional area of core conductor: 16–35 mm ² ; Outer diameter: 26–32 mm
6		RS485 signal cable (Optional)
7	RJ45 network cable	Outdoor eight-conductor shielded twin-twisted pair cable Cross-sectional area of core conductor: 0.13–0.2 mm ² ; Outer diameter: 4–7.5 mm Length: ≤ 100 m ^[1]
8	DI/DO signal cable (Optional)	Outdoor two-conductor shielded cable Cross-sectional area of core conductor: 0.2–1.5 mm ² ; Outer diameter: 2–4 mm

Note [1]: The communication distance limits the cable length. If the cable is too long, it will affect the communication effect. FE communication distance: ≤ 100 m.

Chapter 8 Site Selection Requirement

Tips

The warranty applies when the equipment has been installed properly for its intended use and in accordance with the operating instructions.

Installation environment

- Do not install the equipment in smoky, flammable, or explosive environments.
- Avoid exposing the equipment to direct sunlight, rain, standing water, snow, or dust. Install the equipment in a sheltered place. Take preventive measures in operating areas prone to natural disasters such as floods, mudslides, earthquakes, and typhoons.
- Do not install the equipment in an environment with strong electromagnetic interference.
- Ensure that the temperature and humidity of the installation environment comply with the equipment's requirements.
- The equipment should be installed in an area that is at least 500 m away from corrosion sources that may result in salt damage or acid damage (corrosion sources include but are not limited to seaside, thermal power plants, chemical plants, smelters, coal plants, rubber plants, and electroplating plants).

Installation position

- Do not tilt or overturn the equipment to ensure that it is installed horizontally.
- Do not install the equipment in places easily touched by children.
- Do not install the equipment in places with fire or damp.
- Please keep away from the daily work and living places.
- Do not install the equipment in places that are enclosed, unventilated, without fire fighting facilities, or difficult for firefighters to access.
- Do not install the equipment in mobile scenarios such as RVS, cruise ships, and trains.
- You are advised to install the equipment in places that are easy to access, install, operate, maintain, and view indicator status.
- When installing the equipment in the garage, do not install the equipment in the position where the vehicle passes through to avoid collision.

Mounting surface

- Do not install the equipment on a flammable carrier.
- The installation carrier must meet load-bearing requirements. Solid brick-concrete structure, concrete walls is recommended.

- The surface of the installation carrier must be smooth and the installation area must meet the installation space requirements.
- No water or electricity is routed inside the carrier to prevent drilling hazards during equipment installation.

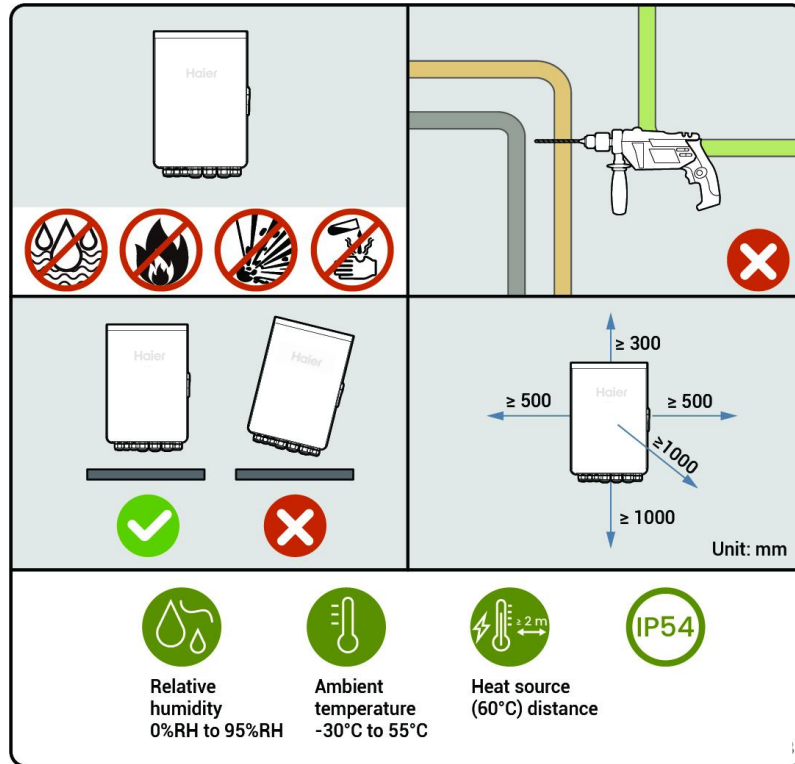

Chapter9 Equipment Installation

There are two installation methods for the Wall mounting hardware
Please refer to the actual product received for detailed instructions.

Option 1

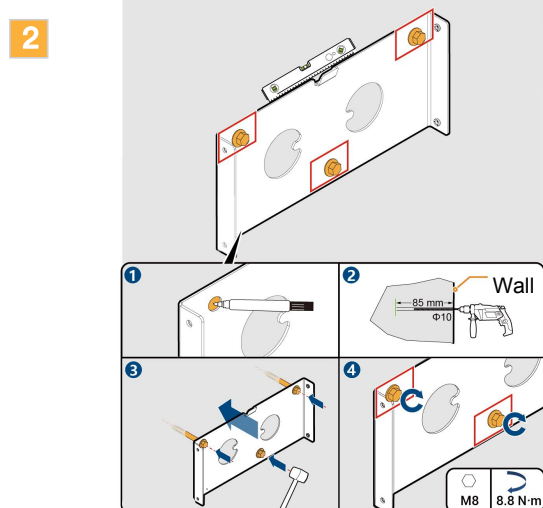
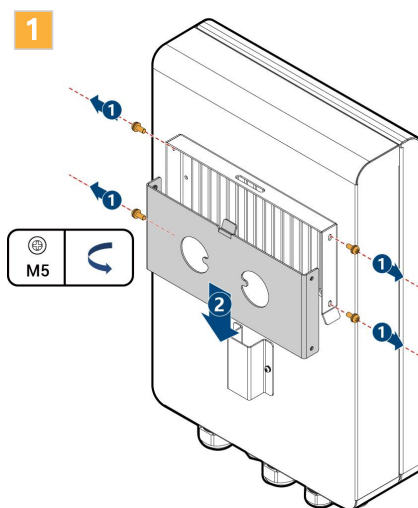

Option 2

1

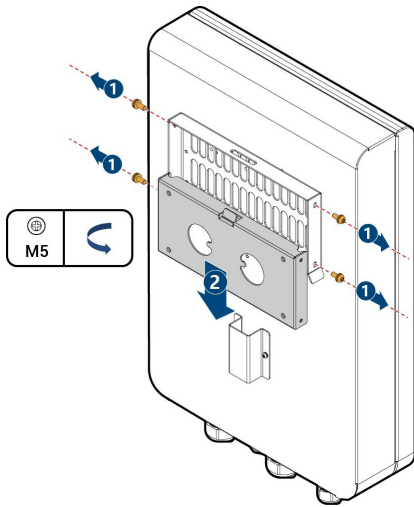

2

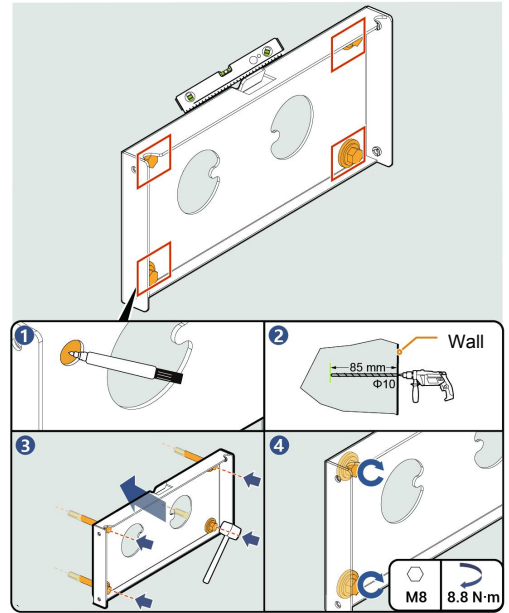

3

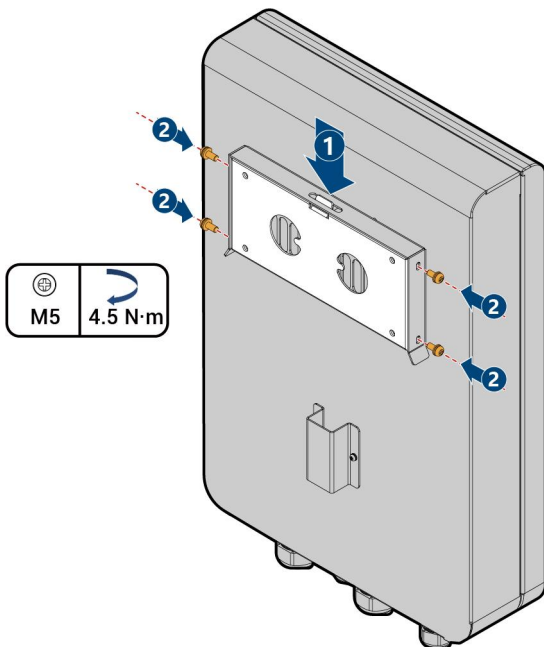

4

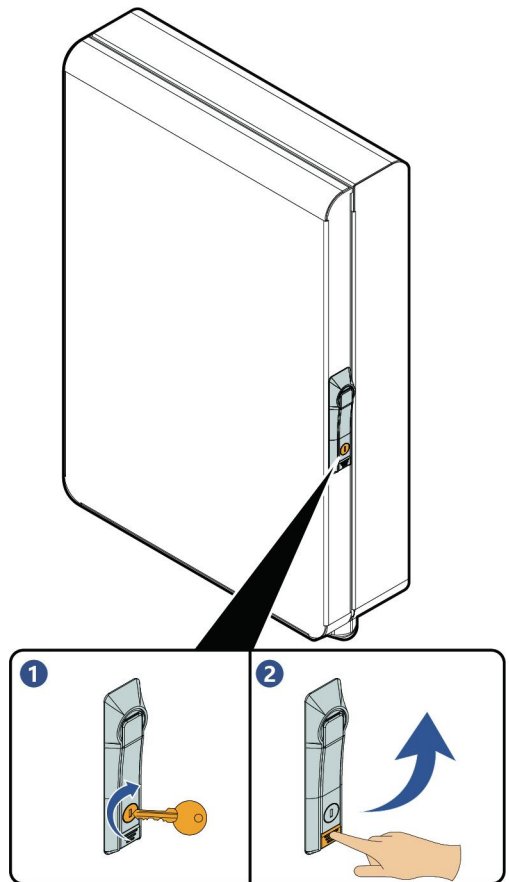

5

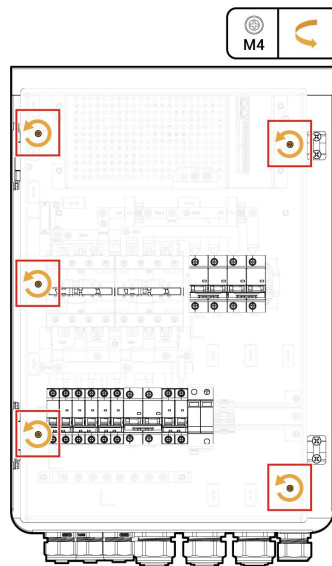

Chapter 10 Cable Connection

10.1 Connected to Power grid

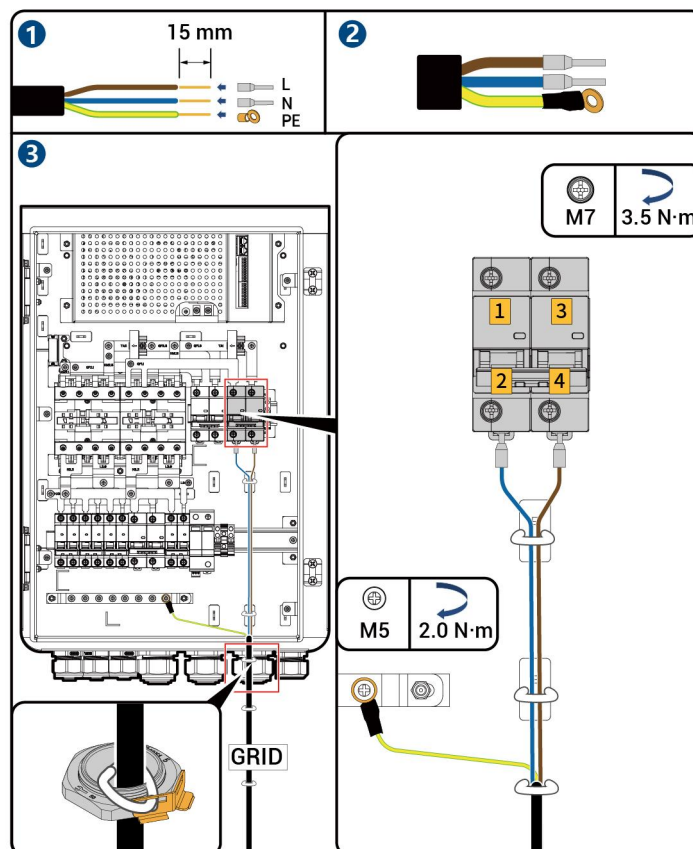

5.2 Functional ground cable

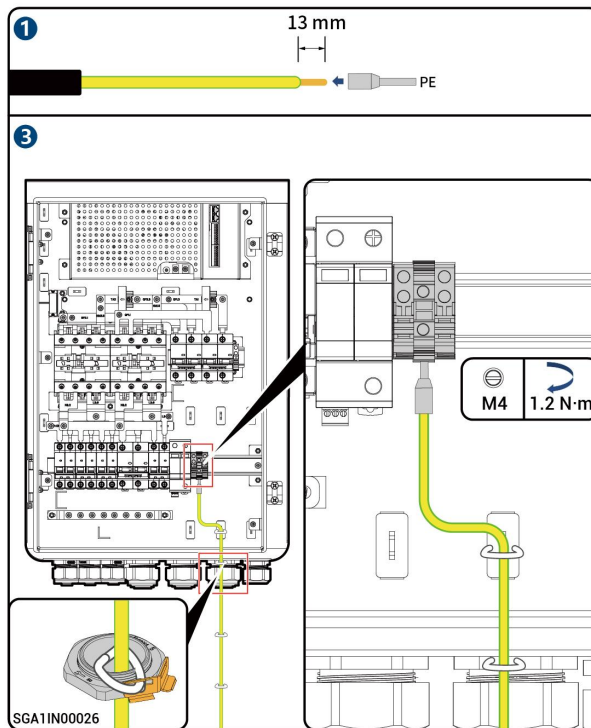

10.3 Connected to inverter

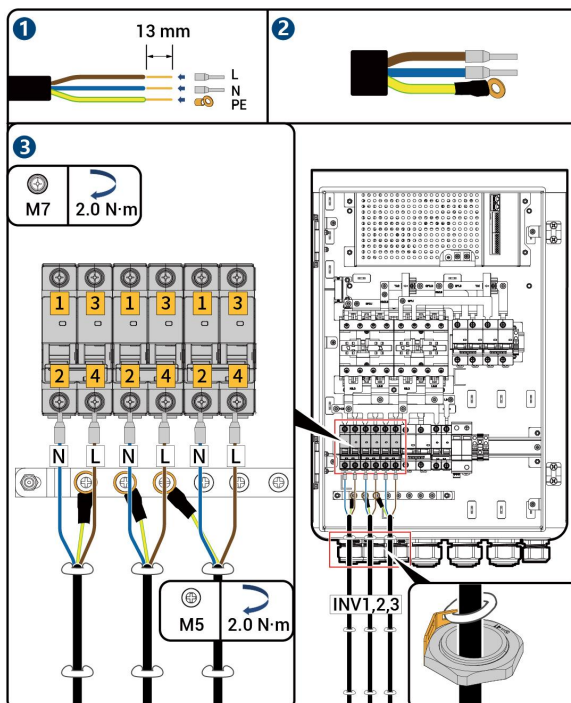

10.4 Connected to Distribution Panel

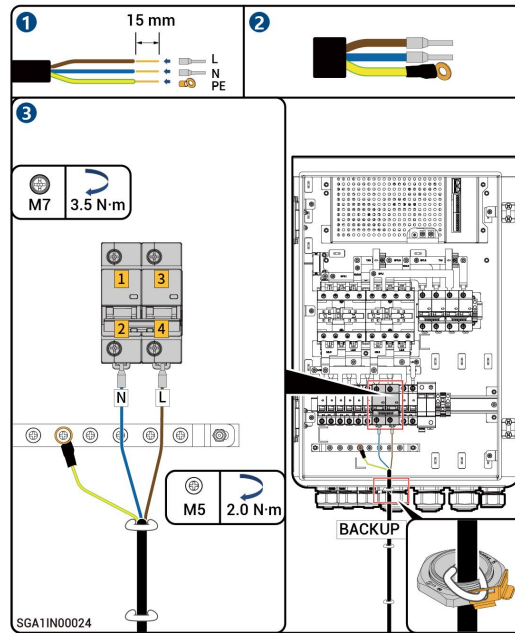

10.5 (Optional) Connected to Controllable loads / Diesel generator

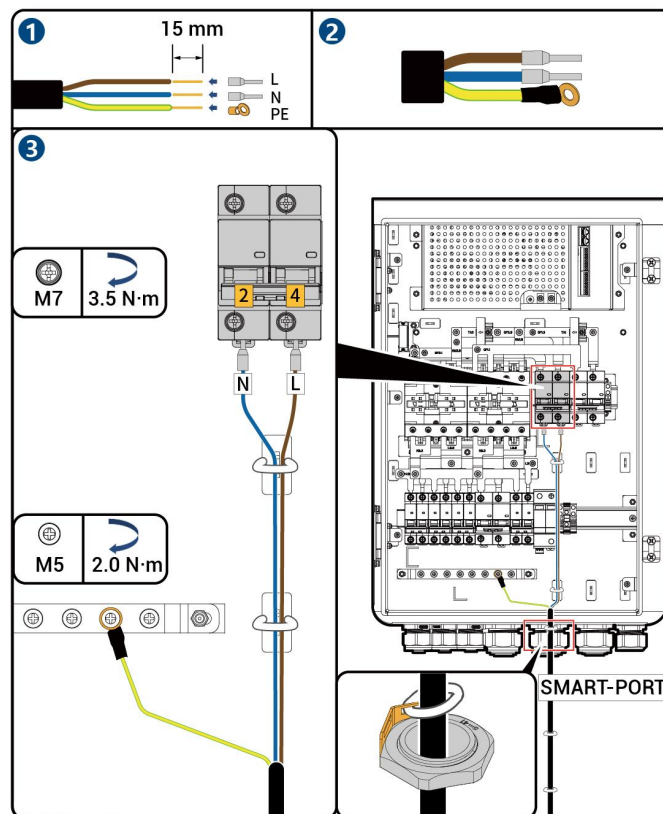

10.6 FE, RS485, DI, and DO Terminals Introduction

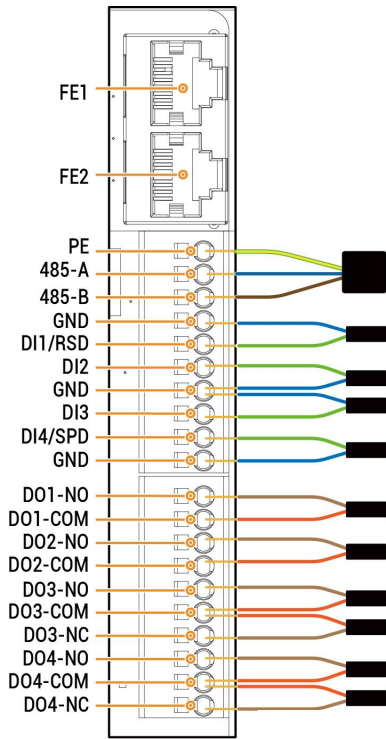

Interface Description	Definition	Function	Description
FE (Network cable interface)	FE1	Fast Ethernet 1	Used to connect an inverter.
	FE2	Fast Ethernet 2	Used to connect an EV AC charger.
485 (RS485 interface)	PE	Signal shield GND	Used to connect smart loads including heat pump, air conditioner, and diesel generator.
	485-A	RS485 signal 2_A+	
	485-B	RS485 signal 2_B-	
DI (Digital input)	GND	Signal GND	Universal DI interfaces, supporting rapid shutdown input signal and surge protection device status feedback input signal, among others.
	DI1/RSD	Digital input 1 / Rapid shutdown	
	DI2	Digital input 2	
	GND	Signal GND	
	DI3	Digital input 3	
	DI4/SPD	Digital input 4 / surge protection device	
	GND	Signal GND	
DO1 (Dry contact 1)	DO1-NO	Digital output 1 - Normal Open	Universal DO interfaces with contact capacity of 30 V DC at 1 A. NO/COM is normally open contact and NC/COM is normally close contact. The DO3/GEN interface can be used for controlling diesel generator start in two-wire start mode.
	DO1-COM	Digital output 1 - Common	
DO2 (Dry contact 2)	DO2-NO	Digital output 2 - Normal Open	
	DO2-COM	Digital output 2 - Common	
DO3/GEN (Digital output 3 / Diesel generator startup)	DO3-NO	Digital output 3 - Normal Open	
	DO3-COM	Digital output 3 - Common	
	DO3-NC	Digital output 3 - Normal Close	
DO4 (Dry contact 4)	DO4-NO	Digital output 4 - Normal Open	
	DO4-COM	Digital output 4 - Common	
	DO4-NC	Digital output 4 - Normal Close	

10.7 RJ45 Cable

Tips

- Two RJ45 network ports: One for the inverter and the other for other equipment,
- RJ45 cables are EIA/TIA 568B standard cable.

- 1**
- ① White orange
 - ② Orange
 - ③ White green
 - ④ Blue
 - ⑤ White blue
 - ⑥ Green
 - ⑦ White brown
 - ⑧ Brown

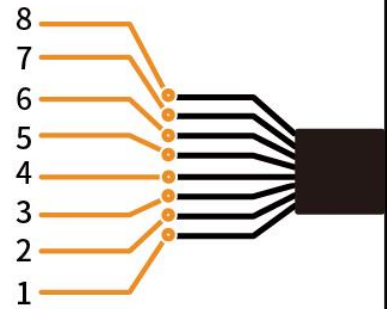
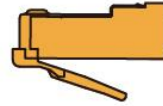
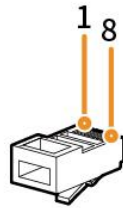

2

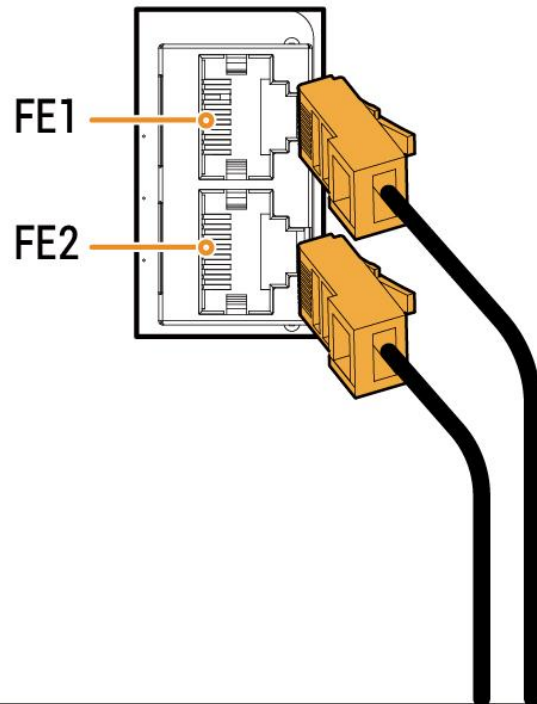
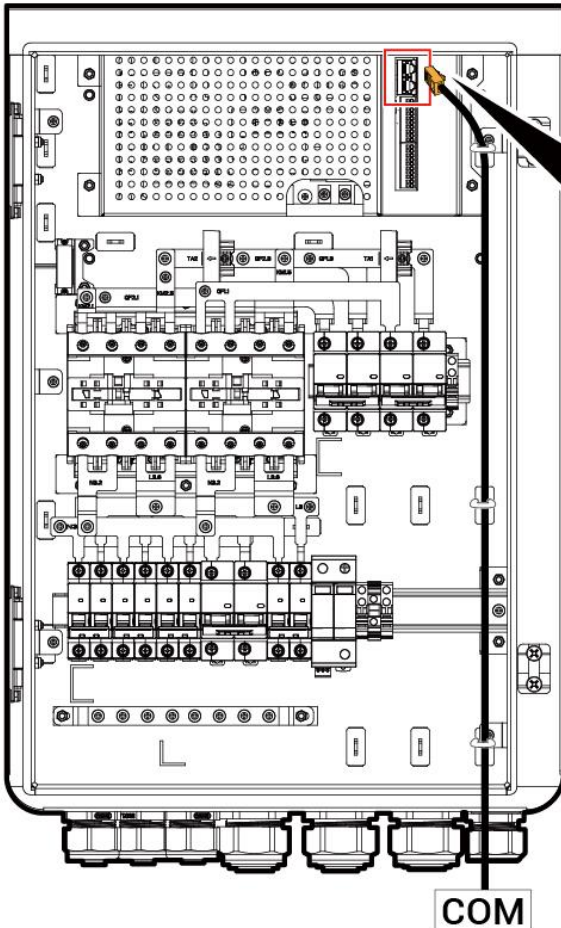

10.8 RS485 Cable

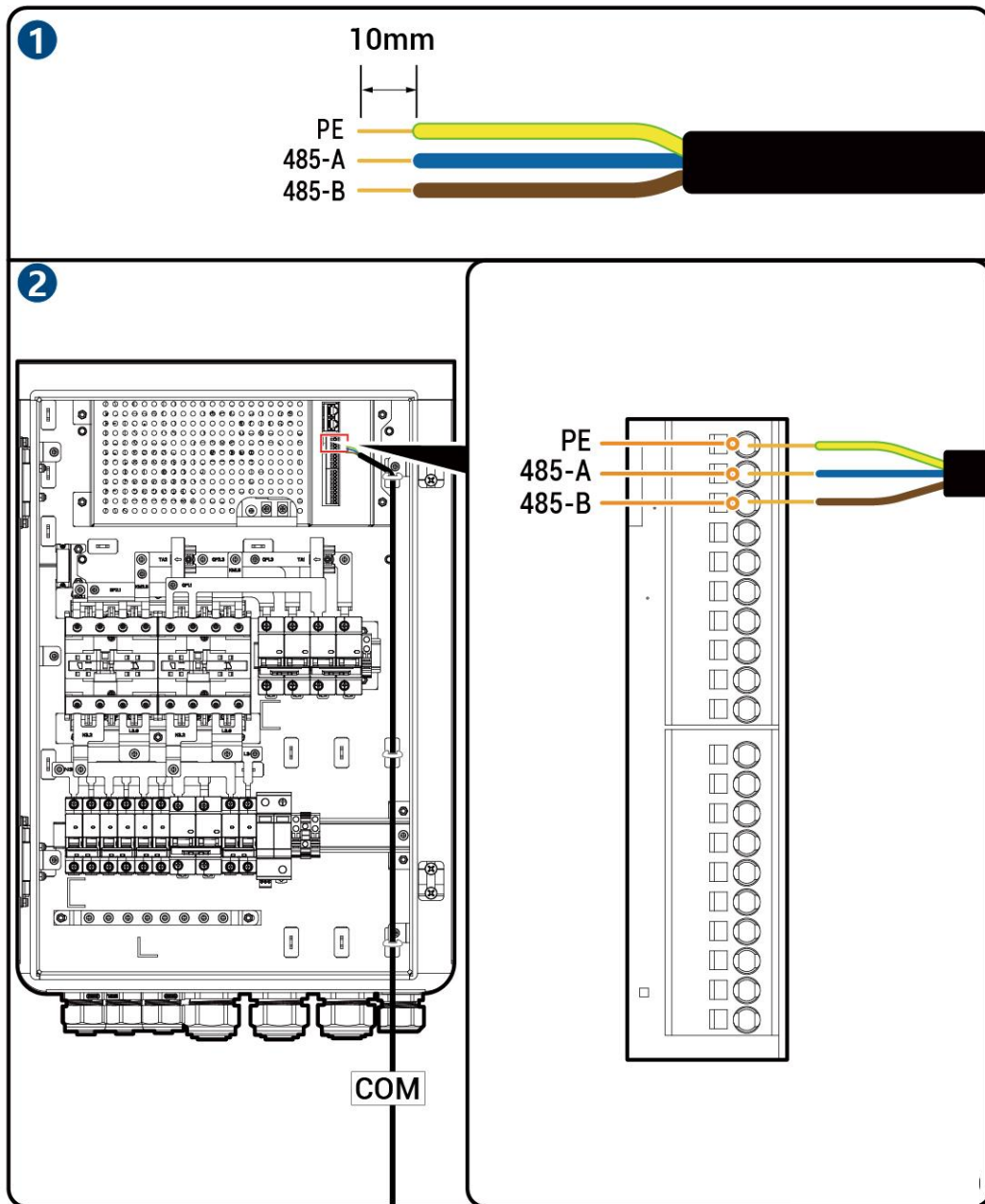

10.9 DI, DO Cable

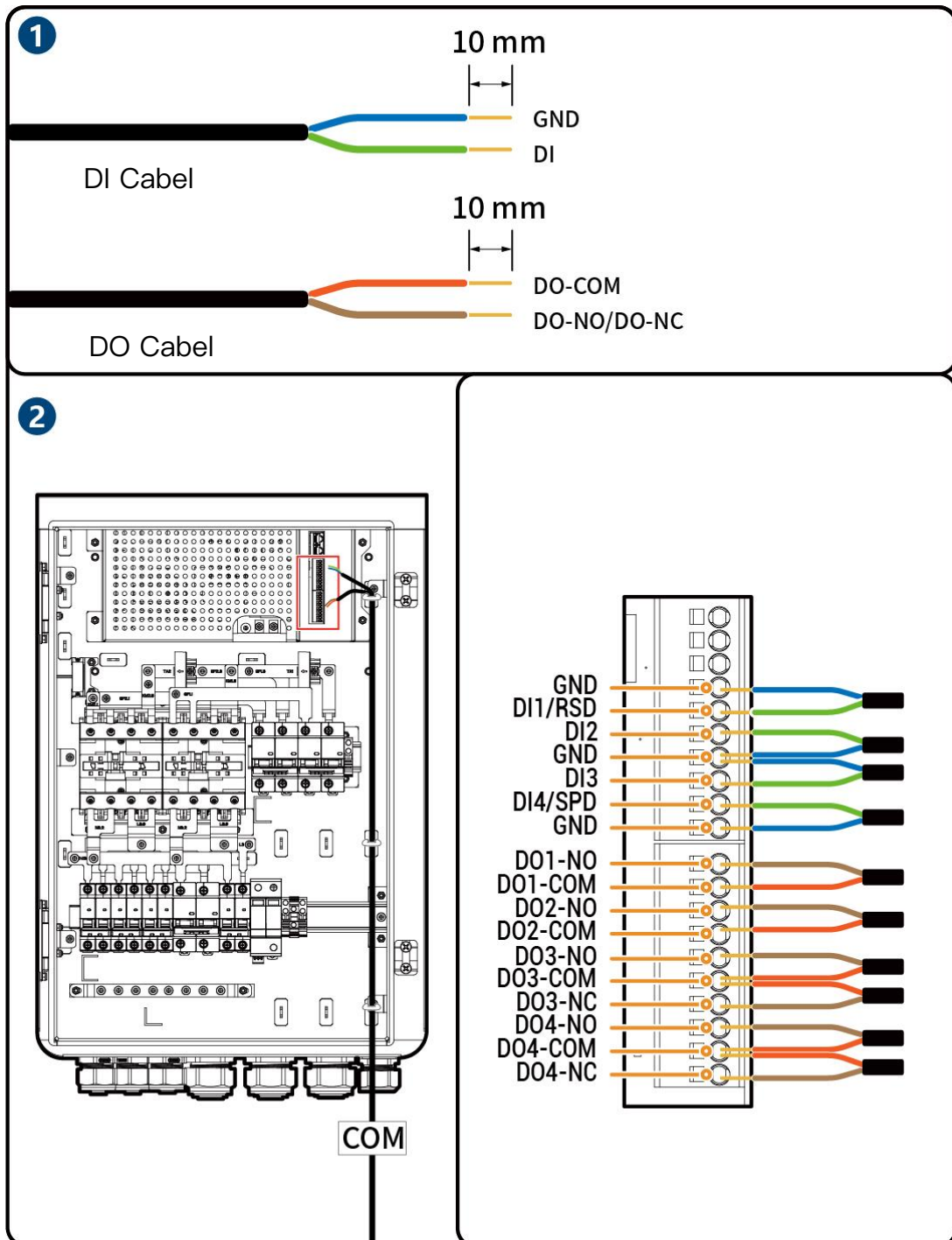

10.10 Internal panel installation

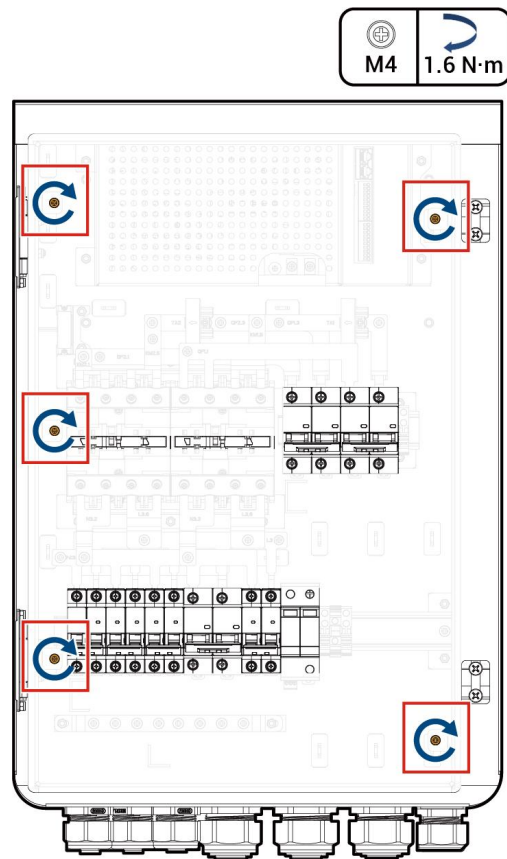

Chapter 11 Post-installation Check

S/N	Check Item
1	The equipment has been securely installed.
2	Ground cables, DC cables, signal cables, etc. are installed accurately without leftovers.
3	The cable fastening screws or terminals are properly installed.
4	There are no sharp spikes or acute angles at the cut point of the cable tie.
5	The Gateway protective cover is locked.
6	There is no construction left inside or outside the equipment.

Chapter12 Equipment Power-On

Tips

- Turn on the front switch of the equipment.
- There is a risk of electric shock if the Gateway is left ungrounded.

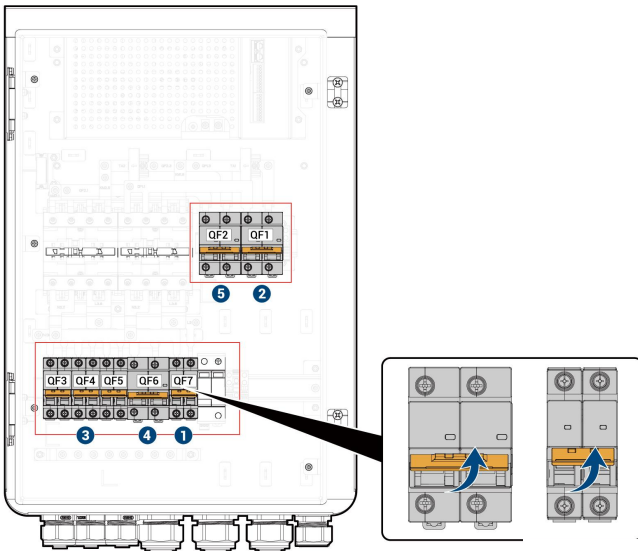

1

1 Switch on the circuit breaker (Surge Protection Device) QF7 and the Surge Protection Device will be enabled.

2 Switch on the circuit breaker (Power grid) QF1 and connect the equipment to the power grid.

3 Switch on the circuit breaker (Inverter) QF3, QF4, QF5 and check whether the inverter is turned on.

4 Switch on the circuit breaker (Distribution panel) QF6 and connect the equipment to the Distribution panel.

5 (Optional) Switch on the circuit breaker (Diesel generator) QF2 and connect the equipment to the diesel generator.

2

Upon completion of the operation, close the front panel of the Gateway and lock the sides with the key delivered with the case; the power-on is completed.

Haier



Official website of NAHUI



Haier Smart Cube

Qingdao Nahui Intelligent Technology Co., Ltd.

📍 Room 205-2, Building 4, No. 7 Keji 1st Road, Aoshanwei Street Office,
Jimo District, Qingdao City, Shandong Province, P.R. China

🌐 www.eur.nahui-newenergy.com

20240418_V1.0