

# User Manual

## PV Grid-Connected Inverter

SG305HX / SG320HX-20 / SG350HX-20





---

# All Rights Reserved

## All Rights Reserved

No part of this document can be reproduced in any form or by any means without the prior written permission of Sungrow Power Supply Co., Ltd (hereinafter "SUNGROW").

## Trademarks

**SUNGROW** and other Sungrow trademarks used in this manual are owned by SUNGROW.

All other trademarks or registered trademarks mentioned in this manual are owned by their respective owners.

## Software Licenses

- It is prohibited to use data contained in firmware or software developed by SUNGROW, in part or in full, for commercial purposes by any means.
- It is prohibited to perform reverse engineering, cracking, or any other operations that compromise the original program design of the software developed by SUNGROW.

# About This Manual

The manual mainly contains the product information, as well as guidelines for installation, operation, and maintenance. The manual does not include complete information about the photovoltaic (PV) system. Readers can get additional information at [www.sungrowpower.com](http://www.sungrowpower.com) or on the webpage of the respective component manufacturer.

## Validity

This manual is valid for the following model of low-power grid-connected PV string inverters:

- SG305HX
- SG320HX-20
- SG350HX-20

It will be referred to as "inverter" hereinafter unless otherwise specified.

## Target Group

This manual is intended for professional technicians who are responsible for installation, operation, and maintenance of inverters, and users who need to check inverter parameters.

The inverter must only be installed by professional technicians. The professional technician is required to meet the following requirements:

- Know electronic, electrical wiring and mechanical expertise, and be familiar with electrical and mechanical schematics.
- Have received professional training related to the installation and commissioning of electrical equipment.
- Be able to quickly respond to hazards or emergencies that occur during installation and commissioning.
- Be familiar with local standards and relevant safety regulations of electrical systems.
- Read this manual thoroughly and understand the safety instructions related to operations.

## How to Use This Manual

Please read this manual carefully before using the product and keep it properly at a place for easy access.

All contents, pictures, marks, and symbols in this manual are owned by SUNGROW. No part of this document may be reprinted by the non-internal staff of SUNGROW without written authorization.

Contents of this manual may be periodically updated or revised, and the actual product purchased shall prevail. Users can obtain the latest manual from [support.sungrowpower.com](http://support.sungrowpower.com) or sales channels.

## Symbols

This manual contains important safety instructions, which are highlighted with the following symbols, to ensure personal and property safety during usage, or to help optimize the product performance in an efficient way.

Please carefully understand the meaning of these warning symbols to better use the manual.

### **DANGER**

Indicates high-risk potential hazards that, if not avoided, may lead to death or serious injury.

### **WARNING**

Indicates moderate-risk potential hazards that, if not avoided, may lead to death or serious injury.

### **CAUTION**

Indicates low-risk potential hazards that, if not avoided, may lead to minor or moderate injury.

### **NOTICE**

Indicates potential risks that, if not avoided, may lead to device malfunctions or financial losses.



“NOTE” indicates additional information, emphasized contents or tips that may be helpful, e.g., to help you solve problems or save time.

# Contents

---

All Rights Reserved.....	I
About This Manual.....	II
<b>1 Safety Instructions.....</b>	<b>1</b>
1.1 Unpacking and Inspection.....	2
1.2 Installation Safety.....	3
1.3 Electrical Connection Safety.....	3
1.4 Operation Safety.....	5
1.5 Maintenance Safety.....	6
1.6 Disposal Safety.....	7
<b>2 Product Description.....</b>	<b>8</b>
2.1 System Introduction.....	8
2.2 Product Introduction.....	9
2.3 Symbols on Product.....	11
2.4 LED Indicator.....	11
2.5 DC Switch.....	12
2.6 Circuit Diagram.....	13
2.7 Function Description.....	14
<b>3 Unpacking and Storage.....</b>	<b>15</b>
3.1 Unpacking and Inspection.....	15
3.2 Unpacking Steps.....	16
3.3 Inverter Storage.....	17
<b>4 Mechanical Mounting.....</b>	<b>19</b>
4.1 Safety During Mounting.....	19
4.2 Location Requirements.....	20
4.2.1 Installation Environment Requirements.....	20
4.2.2 Carrier Requirements.....	22
4.2.3 Angle Requirements.....	22
4.2.4 Installation Space Requirements.....	24

4.3 Installation Tools.....	26
4.4 Moving Inverter.....	28
4.4.1 Manual Transport.....	29
4.4.2 Hoisting Transport.....	29
4.5 Installing Mounting-bracket.....	31
4.5.1 Bracket-Mounted Installation.....	32
4.5.2 Pole-Mounting.....	33
4.6 Installing the Inverter.....	35
<b>5 Electrical Connection.....</b>	<b>37</b>
5.1 Safety Instructions.....	37
5.2 Terminal Description.....	39
5.3 Electrical Connection Overview.....	40
5.4 Crimp OT/DT terminal.....	43
5.5 External Protective Grounding Connection.....	44
5.5.1 External Protective Grounding Requirements.....	44
5.5.2 Connection Procedure.....	45
5.6 AC Cable Connection.....	45
5.6.1 AC Side Requirements.....	45
5.6.2 Requirements for OT/DT Terminal.....	48
5.6.3 One-wire-per-phase Wiring (with Multi-core Cable).....	49
5.6.4 One-wire-per-phase Wiring, Duplex Junction Box (with Multi-core Cable).....	56
5.6.5 Two-wires-per-phase Wiring, Duplex Junction Box (with Multi-core Cable).....	64
5.7 DC Cable Connection.....	71
5.7.1 PV Input Configuration.....	73
5.7.2 Assembling PV Connectors.....	74
5.7.3 Installing PV Connector.....	76
5.8 Wiring of Tracking System Power Cable.....	77
5.9 RS485 Connection(COM1).....	79
5.9.1 Interface Description.....	79
5.9.2 RS485 Communication System.....	80
5.9.3 Connection Procedure.....	81
5.10 PLC Communication Connection.....	84
5.10.1 Application Scenarios.....	85

5.10.2 AC Wring Rules.....	87
5.10.3 PLC Wiring.....	92
<b>6 Commissioning.....</b>	<b>94</b>
6.1 Inspection Before Commissioning.....	94
6.2 Commissioning Procedure.....	94
<b>7 iSolarCloud App.....</b>	<b>97</b>
7.1 Brief Introduction.....	97
7.2 Installing App.....	97
7.3 Login.....	98
7.3.1 Requirements.....	98
7.3.2 Login Procedure.....	98
7.4 Function Overview.....	101
7.5 Home.....	101
7.6 Run Information.....	103
7.7 Records.....	105
7.8 More.....	107
7.8.1 System Parameters.....	107
7.8.2 Operation Parameters.....	108
7.8.3 Power Regulation Parameters.....	109
7.8.4 Communication Parameters.....	115
7.8.5 Firmware Update.....	116
7.8.6 Password Changing.....	117
<b>8 Troubleshooting and Maintenance.....</b>	<b>118</b>
8.1 Troubleshooting.....	118
8.2 Maintenance.....	126
8.2.1 Maintenance Notices.....	126
8.2.2 Disconnecting Inverter.....	127
8.2.3 Routine Maintenance.....	127
8.2.4 Cleaning Air Inlet and Outlet.....	128
8.2.5 Fan Maintenance.....	128
8.2.6 DC Switch Maintenance.....	131
8.3 Inverter Disposal.....	131
8.3.1 Dismantling the Inverter.....	132
8.3.2 Disposal of Inverter.....	132

<b>9 Appendix.....</b>	<b>134</b>
9.1 Technical Data.....	134
9.2 Quality Assurance.....	138
9.3 Contact Information.....	138

# 1 Safety Instructions

When installing, commissioning, operating, and maintaining the product, strictly observe the labels on the product and the safety requirements in the manual. Incorrect operation or work may cause:

- Injury or death to the operator or a third party.
- Damage to the product and other properties.

## WARNING

- **Do not perform any operation on the product (including but not limited to, handling, installing, powering on, or maintaining the product, performing electrical connection, and working at heights) in harsh weather conditions, such as thunder and lightning, rain, snow, and Level 6 or stronger winds. SUNGROW shall not be held liable for any damage to the device due to force majeure, such as earthquakes, floods, volcanic eruptions, mudslides, lightning strikes, fires, wars, armed conflicts, typhoons, hurricanes, tornadoes, and other extreme weathers.**
- **In case of fire, evacuate from the building or product area and call the fire alarm. Re-entry into the burning area is strictly prohibited under any circumstances.**

## NOTICE

- **Tighten the screws with the specified torque using tools when fastening the product and terminals. Otherwise, the product may be damaged. And the damage caused is not covered by the warranty.**
- **Learn how to use tools correctly before using them to avoid hurting people or damaging the device.**
- **Maintain the device with sufficient knowledge of this manual and use proper tools.**



- The safety instructions in this manual are only supplements and cannot cover all the precautions that should be followed. Perform operations considering actual onsite conditions.
- SUNGROW shall not be held liable for any damage caused by violation of general safety operation requirements, general safety standards, or any safety instruction in this manual.
- When installing, operating, and maintaining the product, comply with local laws and regulations. The safety precautions in this manual are only supplements to local laws and regulations.
- During the product transport, installation, wiring, maintenance, etc., the materials and tools prepared by users must meet the requirements of applicable local laws and regulations, safety standards, and other specifications. SUNGROW shall not be held liable for any damage to the product caused by the adoption of materials and tools that fail to meet the above-mentioned requirements.
- Operations on the product, including but not limited to, handling, installing, wiring, powering on, maintenance, and use of the product, must not be performed by unqualified personnel. SUNGROW shall not be held liable for any damage to the product resulting from operations done by unqualified personnel.
- Where the transport of the product is arranged by users, SUNGROW shall not be held liable for any damage to the product that is caused by users themselves or the third-party transport service providers designated by the users.
- SUNGROW shall not be held liable for any damage to the product caused by the negligence, intent, fault, improper operation, and other behaviors of users or third-party organizations.
- SUNGROW shall not be held liable for any damage to the product arising from reasons unrelated to SUNGROW.

## 1.1 Unpacking and Inspection

### **WARNING**

- **Check all safety signs, warning labels and nameplates on devices.**
- **The safety signs, warning labels and nameplates must be clearly visible and cannot be removed or covered before the device is decommissioned.**

**NOTICE**

After receiving the product, check whether the appearance and structural parts of the device are damaged, and check whether the packing list is consistent with the actual ordered product. If there are problems with the above inspection items, do not install the device and contact your distributor first. If the problem persists, contact SUNGROW in time.

## 1.2 Installation Safety

**⚠ DANGER**

- Make sure there is no electrical connection before installation.
- Before drilling, avoid the water and electricity wiring in the wall.

**⚠ CAUTION**

Improper installation may cause personal injury!

- If the product supports hoisting transport and is hoisted by hoisting tools, no one is allowed to stay under the product.
- When moving the product, be aware of the product weight and keep the balance to prevent it from tilting or falling.

**NOTICE**

Before operating the product, must check and ensure that tools to be used have been maintained regularly.

## 1.3 Electrical Connection Safety

**⚠ DANGER**

- Before electrical connections, please make sure that the inverter is not damaged, otherwise it may cause danger!
- Before electrical connections, please make sure that the inverter switch and all switches connected to the inverter are set to "OFF", otherwise electric shock may occur!

** DANGER**

The PV string will generate lethal high voltage when exposed to sunlight.

- Operators must wear proper personal protective equipment during electrical connections.
- Must ensure that cables are voltage-free with a measuring instrument before touching DC cables.
- Respect all safety instructions listed in relevant documents about PV strings.
- The inverter must not be connected to a PV string that requires positive or negative grounding.

** DANGER**

Danger to life due to a high voltage inside the inverter!

- Be sure to use special insulation tools during cable connections.
- Note and observe the warning labels on the product, and perform operations strictly following the safety instructions.
- Respect all safety instructions listed in this manual and other pertinent documents.

** WARNING**

Damage to the product caused by incorrect wiring is not covered by the warranty.

- Electrical connection must be performed by professionals.
- All cables used in the PV generation system must be firmly attached, properly insulated, and adequately dimensioned.

**⚠ WARNING**

- Check the positive and negative polarity of the PV strings, and connect the PV connectors to corresponding terminals only after ensuring polarity correctness.
- During the installation and operation of the inverter, please ensure that the positive or negative poles of PV strings do not short-circuit to the ground. Otherwise, an AC or DC short-circuit may occur, resulting in equipment damage. The damage caused by this is not covered by the warranty.
- Do not connect any load between the inverter and the AC circuit breaker directly connected to it, so as to prevent the switch from tripping by mistake.
- Determine the specifications of AC circuit breakers strictly in compliance with the applicable local laws and regulations and safety standards or the recommendation by SUNGROW. Otherwise, the switch may not open in time in the event of something abnormal, which may then lead to safety incidents.

**NOTICE**

Comply with the safety instructions related to PV strings and the regulations related to the local grid.

## 1.4 Operation Safety

**⚠ DANGER**

When routing cables, ensure a distance of at least 30 mm between the cables and heat-generating components or areas to protect the insulation layer of cables from aging and damage.

** DANGER**

**When the product is working:**

- Do not touch the product enclosure.
- It is strictly forbidden to plug and unplug any connector on the inverter.
- Do not touch any wiring terminal of the inverter. Otherwise, electric shock may occur.
- Do not disassemble any parts of the inverter. Otherwise, electric shock may occur.
- It is strictly forbidden to touch any hot parts of the inverter (such as the heat sink). Otherwise, it may cause burns.
- Do not connect or remove any PV string or any PV module in a string. Otherwise, electric shock may occur.

## 1.5 Maintenance Safety

** DANGER**

**Risk of inverter damage or personal injury due to incorrect service!**

- Before maintenance, disconnect the AC circuit breaker on the grid side and then the DC switch. If a fault that may cause personal injury or device damage is found before maintenance, disconnect the AC circuit breaker and wait until the night before operating the DC switch. Otherwise, a fire inside the product or an explosion may occur, causing personal injuries.
- After the inverter is powered off for 25 minutes, measure the voltage and current with professional instrument. Only when there is no voltage nor current can operators who wear protective equipment operate and maintain the inverter.
- Even if the inverter is shut down, it may still be hot and cause burns. Wear protective gloves before operating the inverter after it cools down.

** DANGER**

**Touching the power grid or the contact points and terminals on the inverter connected to the power grid may lead to electric shock!**

- The power grid side may generate voltage. Always use a standard voltmeter to ensure that there is no voltage before touching.

**⚠ CAUTION**

To prevent misuse or accidents caused by unrelated personnel, post prominent warning signs or demarcate safety warning areas around the product.

**NOTICE**

To avoid the risk of electric shock, do not perform any other maintenance operations beyond this manual. If necessary, contact SUNGROW for maintenance. Otherwise, the losses caused is not covered by the warranty.

**NOTICE**

- If the paint on the inverter enclosure falls or rusts, repair it in time. Otherwise, the inverter performance may be affected.
- Do not use cleaning agents to clean the inverter. Otherwise, the inverter may be damaged, and the loss caused is not covered by the warranty.
- As the inverter contains no parts that can be maintained, never open the enclosure of the inverter or replace any internal components without authorization. Otherwise, the loss caused is not covered by the warranty.
- Do not open the maintenance door in rainy or snowy weather. If it is inevitable, take proper protective measures to avoid the ingress of rainwater and snow into the maintenance compartment; otherwise, the product's operation may be affected.
- Before closing the maintenance door, check whether there is any object left inside the maintenance compartment, such as screws, tools, etc.
- It is recommended for users to use cable sheathing to protect the AC cable. If the cable sheathing is used, make sure it is positioned inside the maintenance compartment.

## 1.6 Disposal Safety

**⚠ WARNING**

Please scrap the product in accordance with relevant local regulations and standards to avoid property losses or casualties.

## 2 Product Description

### 2.1 System Introduction

The inverter is a transformerless 3-phase PV grid-connected inverter. As an integral component in the PV power system, the inverter is designed to convert the direct current power generated from the PV modules into grid-compatible AC current and to feed the AC current into the utility grid.

#### **WARNING**

**Do not connect any local load between the inverter and the AC circuit breaker except for the tracking axis.**

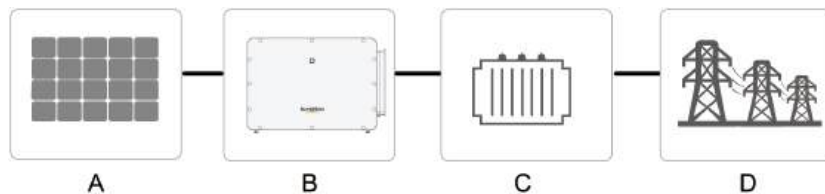
#### **NOTICE**

**When designing the system, ensure that the operating ranges of all devices that are connected to the inverter meet the requirements of the inverter.**

**The PV modules in the system must comply with the IEC 61730-1 (2016) class II standard.**

**The inverter is only applicable to the scenarios described in the manual and cannot be used in other situations.**

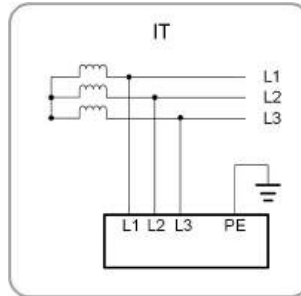
The intended usage of the inverter is illustrated in the following figure.



**figure 2-1** Inverter Application in PV Power System

Item	Description	Note
A	PV strings	Monocrystalline silicon, polycrystalline silicon and thin-film without grounding
B	Inverter	SG305HX / SG320HX-20 / SG350HX-20
C	Transformer	Raises the output voltage of the inverter to a level that meets the requirements of the grid

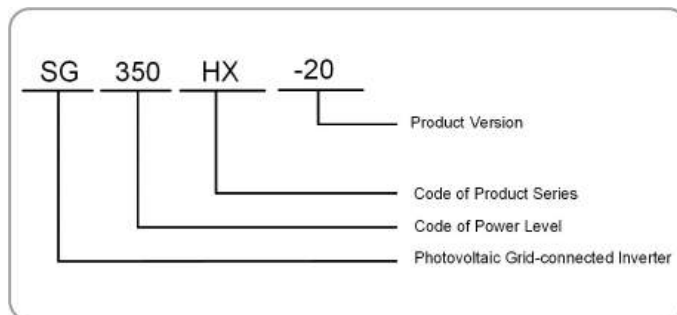
Item	Description	Note
D	Utility grid	The grid form supported by the inverter is shown in the figure below



## 2.2 Product Introduction

### Model Description

The model description is as follows.



### Appearance

The following figure shows the appearance of the inverter.

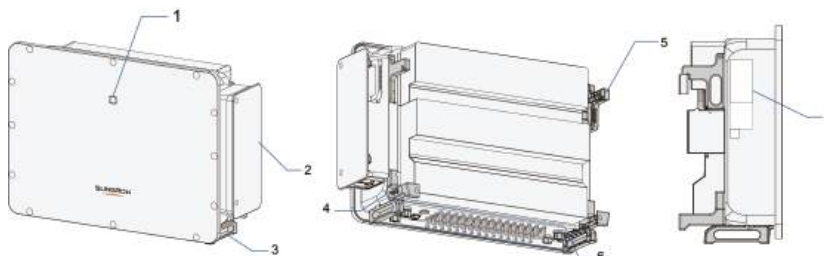


figure 2-2 Appearance

The image shown here is for reference only. The actual product received may differ.

No.	Name	Description
1	LED indicator	To indicate the current working state of the inverter.
2	AC junction box	To connect AC cable and tracking system power cable in this area.
3	External protective grounding terminals	2, use at least one of them to ground the inverter.
4	Bottom handles	2, used to move the inverter.
5	Mounting lugs	2, used to hang the inverter onto the mounting-bracket.
6	Wiring area	DC switches, DC terminals, and communication terminals. For details, refer to <a href="#">5.2 Terminal Description</a> .
7	Labels	To clearly identify the product, including nameplate, warning symbols and QR code.

## Dimensions

The following figure shows the dimensions of the inverter.

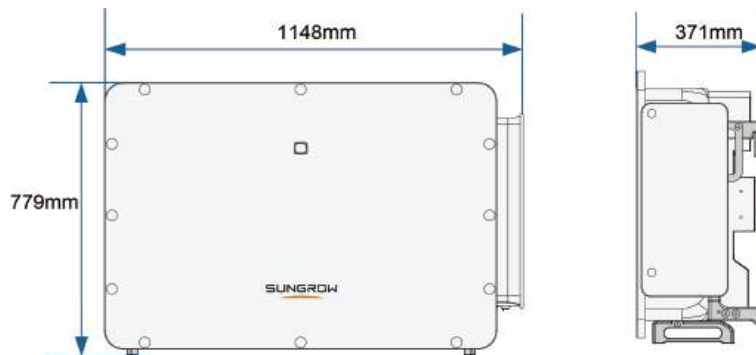











figure 2-3 Product Dimensions(in mm)

Model	Dimensions	Weight
SG305HX/SG320HX-20/ SG350HX-20	1148 mm * 779 mm * 371 mm	≤ 106 kg*

\*:Due to the multi-supplier for some key components, the actual weight may have a  $\pm 8\%$  deviation, please refer to the actually delivered product.




## 2.3 Symbols on Product

Symbol	Explanation
	Do not dispose of the inverter together with household waste.
	Read the user manual before maintenance!
	TUV mark of conformity.
	CE mark of conformity. EU/EEA Importer
	UKCA mark of conformity. The height of the label should not exceed 5 mm.
	Disconnect the inverter from all the external power sources before maintenance!
	Burn danger due to the hot surface that may exceed 60°C.
	Danger to life due to high voltages! Do not touch live parts for 25 minutes after disconnection from the power sources. Only qualified personnel can open and maintain the inverter.
	External protective grounding terminal.

## 2.4 LED Indicator

The LED indicator on the front of the inverter indicates the working state of the inverter.

**table 2-1** LED Indicator State Description

LED Color	State	Definition
 Blue	On	The device is connected to the grid and operating normally.
	Fast blink (Period: 0.2s)	The Bluetooth connection is established, and there is data communication. No system fault occurs.
	Slow blink (Period: 2s)	The device is in standby or startup state (not feeding power into the grid).
	Slow blink once, fast blink three times	The inverter is performing PID recovery.
 Red	On	A fault occurs and the device cannot connect to the grid.
	Blink	The Bluetooth connection is established, data communication in process, and a system fault occurs.
 Gray	OFF	Both the AC and DC sides are powered down.

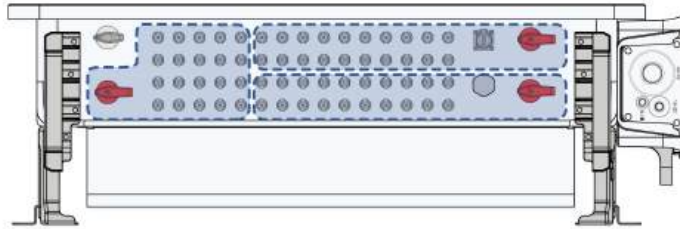
 **WARNING**

**Voltage may still be present in AC side circuits after the indicator is off. Pay attention to the electricity safety when operating.**

## 2.5 DC Switch

The DC switch can safely disconnect the inverter from the PV strings. The inverter is equipped with one auxiliary switch and three DC switches. Three DC switches are used for controlling the PV terminals in three different areas respectively. Upon detecting reverse polarity, back-feeding, or a fault inside the inverter, the DC switch will turn off automatically to interrupt the DC input.

In case the DC switch on the inverter turns off by itself, please proceed by referring to [8.2.6 DC Switch Maintenance](#).



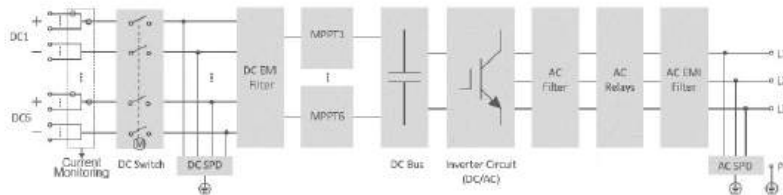
\*The images shown are for illustration purposes only and may not be an exact representation of the actual product.

**table 2-2**

DC switch	PV terminals controlled by the switch
AUXILIARY SWITCH	-
DC SWITCH 1	PV1 ~ PV10
DC SWITCH 2	PV11 ~ PV20
DC SWITCH 3	PV21 ~ PV30

## 2.6 Circuit Diagram

The following figure shows the main circuit of the inverter.



**figure 2-4** Circuit Diagram

- The DC SPD provides a discharge circuit for the DC side overvoltage to prevent it from damaging the internal circuits of the inverter.
- EMI filters can filter out the electromagnetic interference inside the inverter to ensure that the inverter meets the requirements of electromagnetic compatibility standards.
- The MPPT is used to ensure a maximum power from PV arrays at different PV input conditions.
- The Inverter Circuit converts the DC power into grid-compliant AC power and feeds it into the grid.
- The AC filter filters the output AC component of high frequency to ensure that the output current meets the grid requirements.

- The AC relay isolates the AC output of the inverter from the grid, making the inverter safe from the grid in case of inverter failure or grid failure.
- The AC SPD provides a discharge circuit for the AC side overvoltage to prevent it from damaging the internal circuits of the inverter.

** DANGER**

**If the lightning level exceeds the protection level of the product, surge protection and overvoltage protection may fail, resulting in electric shock and fatal injury!**

## 2.7 Function Description

The inverter is equipped with the following functions:

### Conversion Function

The inverter converts the DC current into grid-compatible AC current and feeds the AC current into the grid.

### Data Storage

The inverter logs running information, error records, etc.

### Parameter Configuration

The inverter provides various settable parameters. Users can set parameters via the App to meet the requirements and optimize the performance.

### Communication Interface

The inverter is designed with standard RS485 communication interfaces.

The standard RS485 communication interfaces are used to establish communication connection with monitoring devices and upload monitoring data by using communication cables. After communication connection is established, users can view inverter information or set inverter parameters through the iSolarCloud.

### Protection Function

The protective functions are integrated in the inverter, including anti-island protection, LVRT, DC reverse connection protection, AC short circuit protection, leakage current protection, surge protection, etc.

---

## 3 Unpacking and Storage

### 3.1 Unpacking and Inspection

The product is thoroughly tested and strictly inspected before delivery. Nonetheless, damage may still occur during shipping. For this reason, please conduct a thorough inspection after receiving the product.

- Check the packing case for any visible damage.
- Check the scope of delivery for completeness according to the packing list.
- Check the inner contents for damage after unpacking.

Contact SUNGROW or the transport company in case of any damage or incompleteness, and provide photos to facilitate services.

Do not dispose of the original packing case. It is recommended to store the device in the original packing case when the product is decommissioned.

#### NOTICE

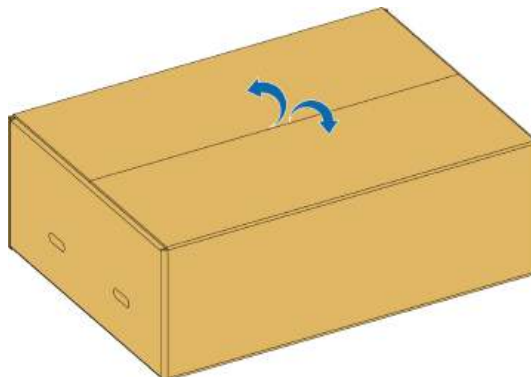
- **After receiving the product, check whether the appearance and structural parts of the device are damaged, and check whether the packing list is consistent with the actual ordered product. If there are problems with the above inspection items, do not install the device and contact your distributor first. If the problem persists, contact SUNGROW in time.**
- **If any tool is used for unpacking, be careful not to damage the product.**

## 3.2 Unpacking Steps

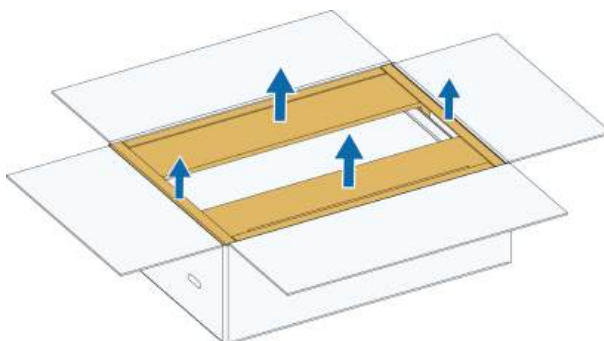
**step 1** Use a utility knife to cut the packing tape. Remove horizontal and vertical paper angle beads.



**step 2** Open the packaging box.

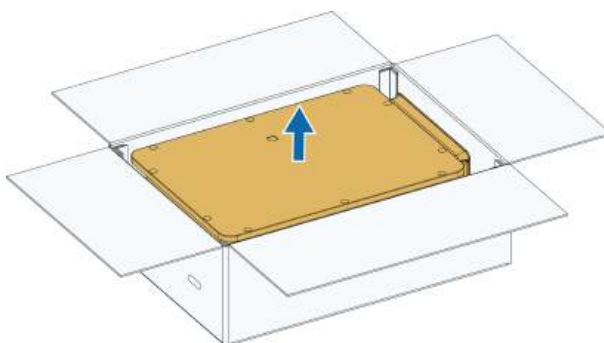


**step 3** Remove the paper angle bead around the inverter.



**step 4** Take out the accessories from the box and keep them in a proper place.

**step 5** Take out the inverter and place it on a flat surface covered with protective materials such as foam or a sponge mat.



-- End

### 3.3 Inverter Storage

Proper storage is required if the inverter is not installed immediately.

- Store the inverter in the original packing case with the desiccant inside.
- The storage temperature must be always between  $-40^{\circ}\text{C}$  and  $+70^{\circ}\text{C}$ , and the storage relative humidity must be always between 0 and 95 %, non-condensing.
- In case of stacking storage, the number of stacking layers should never exceed the limit marked on the outer side of the packing case.
- The packing case should be upright.
- If the inverter needs to be transported again, pack it strictly before loading and transporting it.
- Do not store the inverter in places susceptible to direct sunlight, rain, and strong electric field.
- Do not place the inverter in places with items that may affect or damage the inverter.

- Store the inverter in a clean and dry place to prevent dust and water vapor from eroding.
- Do not store the inverter in places with corrosive substances or susceptible to rodents and insects.
- Carry out periodic inspections. Inspection shall be conducted at least once every six months. If any insect or rodent bites are found, replace the packaging materials in time.
- If the inverter has been stored for more than a year, inspection and testing by professionals are required before it can be put into operation.

**NOTICE**

**Please store the inverter according to the storage requirements. Product damage caused by failure to meet the storage requirements is not covered by the warranty.**

## 4 Mechanical Mounting

### WARNING

Respect all local standards and requirements during mechanical installation.

### 4.1 Safety During Mounting

### DANGER

Make sure there is no electrical connection before installation.  
Before drilling, avoid the water and electricity wiring in the wall.

### WARNING

For specific requirements for the installation environment, see [4.2.1 Installation Environment Requirements](#). In case the environment where the device is installed does not meet the requirements, SUNGROW shall not be held liable for any property damage arising therefrom.

### CAUTION

Improper handling may cause personal injury!

- When moving the inverter, be aware of its weight and keep the balance to prevent it from tilting or falling.
- Wear proper protective equipment before performing operations on the inverter.
- The bottom terminals and interfaces of the inverter cannot directly contact the ground or other supports. The inverter cannot be directly placed on the ground.

### NOTICE

When installing devices, ensure that no device in the system causes it hard for the DC switch and the AC circuit breaker to act or hinders maintenance personnel from operating.

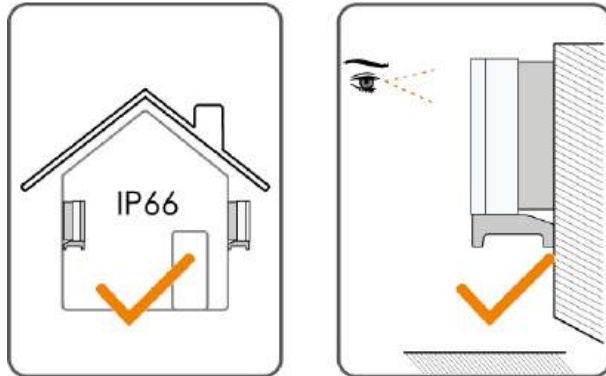
If drilling is required during installation:

- Wear goggles and protective gloves when drilling holes.
- Make sure to avoid the water and electricity wiring in the wall before drilling.
- Protect the product from shavings and dust.

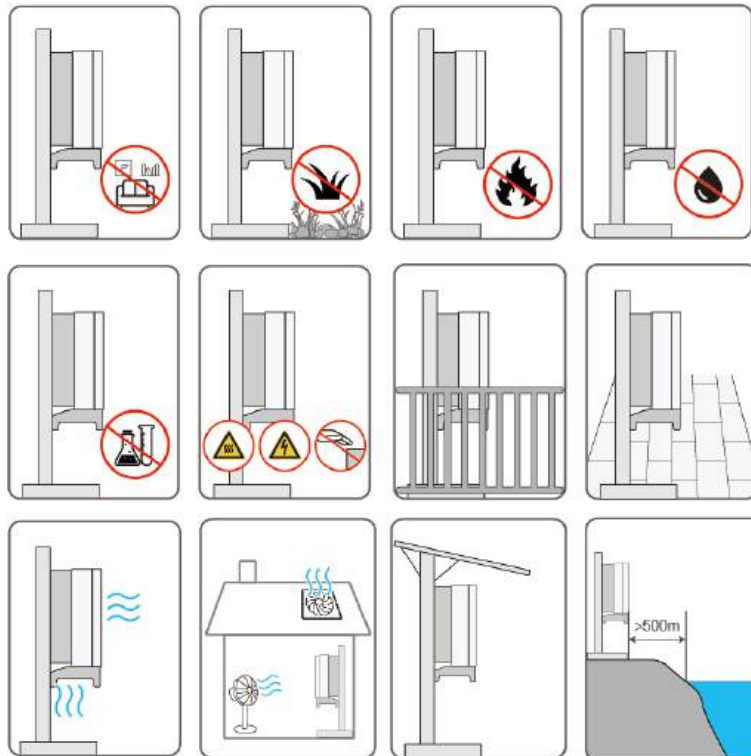
## 4.2 Location Requirements

To a large extent, a proper installation location ensures safe operation, service life, and performance of the inverter.

- The inverter should be installed at a height that allows easy viewing of the LED indicator panel, as well as easy electrical connection, operation and maintenance.



### 4.2.1 Installation Environment Requirements



- If the inverter is installed in a place with lush vegetation, weed on a regular basis. In addition, the ground beneath the inverter needs to undergo certain treatment, such as laying cement or gravel, etc. (an area of 3m×2.5m is recommended).
- Do not install the inverter in an environment with flammables, explosives, or smoke.
- Do not install the inverter in places prone to water leak, e.g., under the air-conditioner vent, the air vent, or the cable outlet window of the machine room, so as to prevent device damage or short circuit caused by intrusion of water.
- Do not install the inverter in a place with corrosives such as corrosive gas and organic solvent, etc.
- When the inverter is running, its surface may carry high voltages or get very hot. Do not touch it; otherwise, it may lead to burns or electric shocks.
- Do not install the inverter in a place that is easy to reach for people.
- Good heat dissipation is very important to the inverter. Please install the inverter in a ventilated environment.
- Install the inverter in a place with shelter, or build a sunshade for it.
- Please consult SUNGROW before installing inverters outdoors in areas prone to salt damage, which mainly are coastal areas within 500 meters of the coast. The sedimentation amount of salt spray is correlated to the characteristics of the seawater, sea winds, precipitation, air humidity, topography, and forest coverage in the adjacent sea areas, and there are substantial differences between different coastal areas.
- Do not install the inverter in an environment contaminated with chemicals such as halogen and sulfide.
- Do not install the inverter in an environment with vibration and strong electromagnetic field. Strong-magnetic-field environments refer to places where magnetic field strength measures over 30 A/m.
- In dusty environments such as places full of dust, smoke, or floc, particles may cling to the device's air outlet or heat sink, thus impacting its heat dissipation performance or even getting it damaged. Therefore, do not install the inverter in dusty environments. If the inverter has to be installed in such environments, please clean its fans and heat sink on a regular basis to ensure a good heat dissipation performance.
- The average temperature approximately 1 m around the inverter should be taken as its operating temperature. The temperature and humidity should meet the requirements below:
- Requirements for the inverter which has been installed but not put into use for a long time:
  - After connecting the DC cables, turn on the DC switches by referring to steps 1 to 4 in [6.2 Commissioning Procedure](#).
  - Be sure to use the blue plugs, which come with the inverter, to close off the unused DC terminals.

- If the inverter is installed in a sandy and windy environment, please add safeguards against sand and dust on the air inlet and outlet of the air duct, so as to avoid impacts on fan operation caused by air duct blockage. Please remove the safeguards before putting the inverter into operation.

#### 4.2.2 Carrier Requirements

The mounting structure where the inverter is installed must comply with local/national standards and guidelines. Ensure that the installation surface is solid enough to bear four times the weight of the inverter and is suitable for the dimensions of the inverter (e.g. cement walls, plasterboard walls, etc.).

Do not install the inverter on a carrier that may vibrate in resonance, so as to avoid making bigger noise.

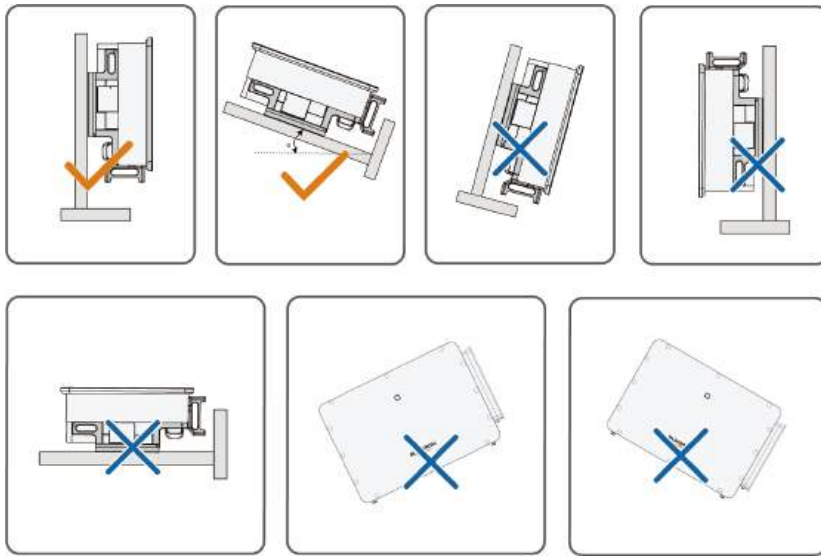
The structure should meet the following requirements:



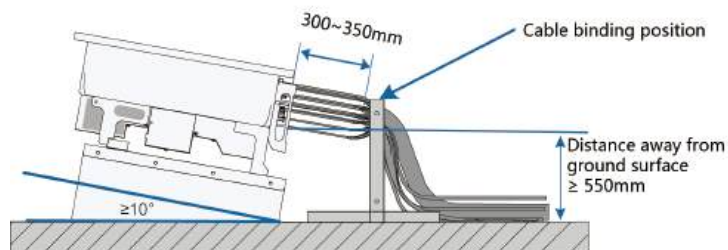
#### 4.2.3 Angle Requirements

Install the inverter vertically or tilt backwards. Do not install the inverter horizontally, forward, excessively backward, sideways, or upside down.

Inverters in floating plants cannot be installed at a back tilt.



In case the installation site is a level surface, mount the inverter to the bracket to meet the mounting angle requirements, as shown in the figure below.



Take the following items into account when designing the bracket scheme:

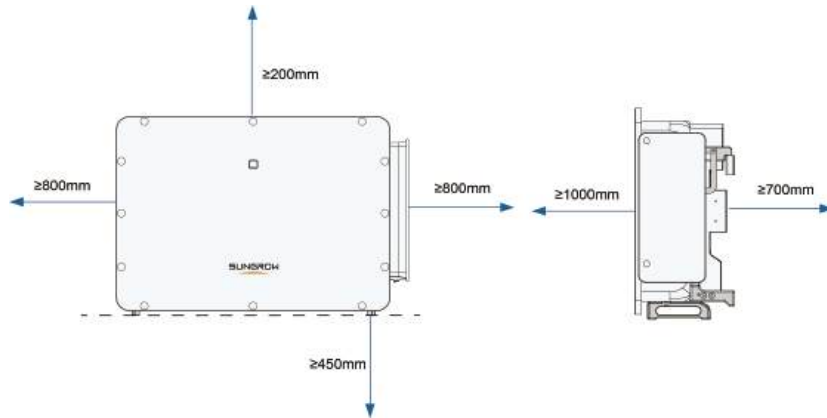
- Consider onsite climate conditions and take anti-snow and anti-rain measures if necessary.
- Ensure that the waterproof connectors are at least 550 mm higher than the ground surface.
- Bind the cables at the positions 300~350 mm away from the DC connector, AC waterproof terminal, and communication waterproof terminal.
- The various waterproof terminals should be tightened with the torque specified in this manual to ensure that they are securely sealed.

Contact SUNGROW if you have any question.

## 4.2.4 Installation Space Requirements

### Space around the inverter

Make sure there is sufficient space around the inverter for good ventilation. The space requirements for installing a single inverter are shown in the figure below.

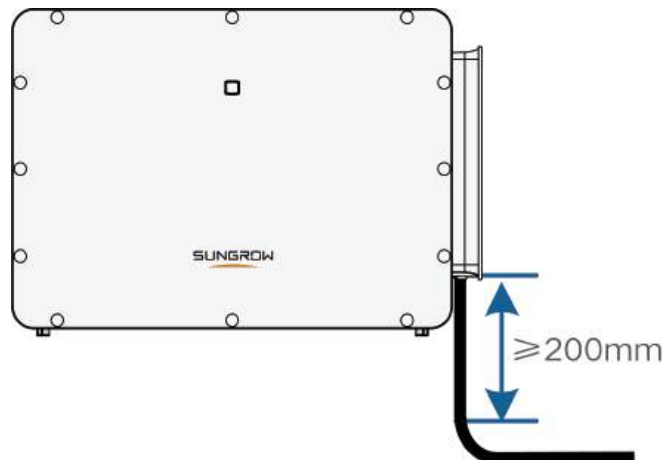


### NOTICE

If the actual space reserved for the inverter is smaller than that required in the figure, before fan maintenance, lift the inverter away from the bracket or wall.

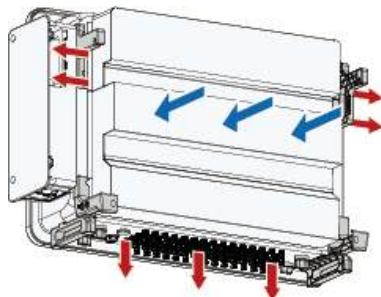


Run the AC cable into the AC terminal vertically, and make sure the cable is kept vertical for a length of  $\geq 200\text{mm}$ .



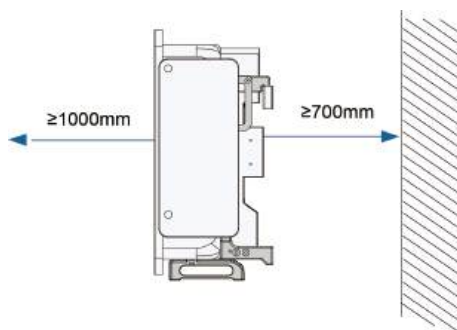
### Air inlets/outlets of the inverter

Make sure there is no obstruction to the inverter's air inlets/outlets, to avoid impacting its heat dissipation. The air inlets/outlets of the inverter are shown in the figure below.



### Inverters installed against the wall

If the inverter is installed against the wall, keep it at least 700mm away from the wall.



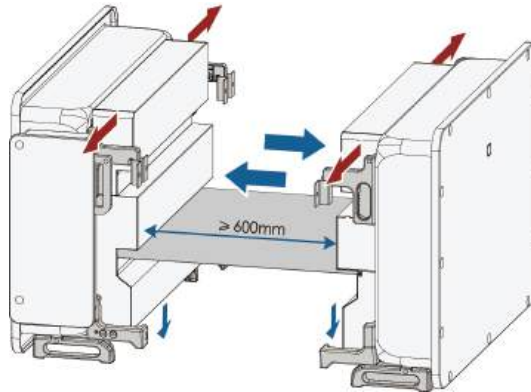
### Inverters installed in one row

When installing multiple inverters, reserve sufficient space between the inverters. It is recommended to position them in one row.

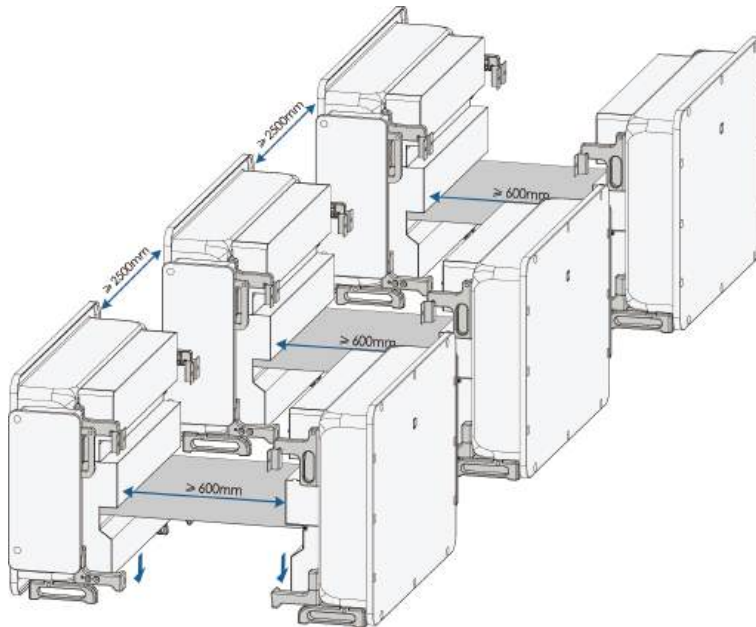


### Inverters installed back-to-back

For two inverters installed back-to-back, the distance between them should be at least 600mm.



When installing more than two inverters back-to-back, sufficient space should be reserved between the adjacent inverters.



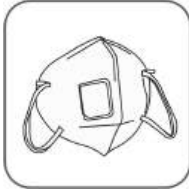

















If the above installation requirements cannot be met, please contact SUNGROW for support.

### 4.3 Installation Tools

Installation tools include but are not limited to the following recommended ones. If necessary, use other auxiliary tools on site.

**table 4-1** Tool specification

			
Goggles	Earplugs	Dust mask	Safety gloves
			
Safety shoes	Utility knife	Slotted screwdriver (M2, M3, M6)	Phillips screwdriver (M4, M6, M8)
			
Hammer drill (φ12)	Pliers	Marker	Level
			
Rubber mallet	Socket wrench set (M4, M8, M12)	Open-end wrench (16 mm, 35 mm)	Anti-static wrist strap
			
Wire cutter	Wire stripper	Hydraulic plier	Heat gun



crimping  
tool(4–6mm<sup>2</sup>)  
Model: PV-  
CZM-41100  
Manufactur-  
er: STAUBLI



Connector wrench



Multimeter  
(≥ 1500 Vdc)



Vacuum cleaner



Scissors



Hexagon sock-  
et wrench  
(T30)



Electric drill  
(φ12)

## 4.4 Moving Inverter

Move the inverters by carrying them manually or using a hoisting tool based on site conditions.

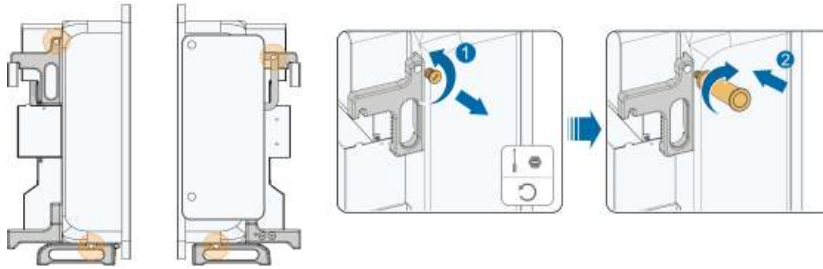
### **⚠ CAUTION**

**Improper handling may cause personal injury!**

- Arrange an appropriate number of personnel to carry the inverter according to its weight, and installation personnel should wear protective equipment such as anti-impact shoes and gloves.
- Attention must be paid to the center of gravity of the inverter to avoid tilting during handling.
- Placing the inverter directly on a hard ground may cause damage to its metal enclosure. Protective materials such as sponge pad or foam cushion should be placed underneath the inverter.
- Move the inverter by holding the handles on it. Do not move the inverter by holding the terminals.

### 4.4.1 Manual Transport

Install the four screw-in handles that are provided to the inverter lugs and the base. Lift and move the inverter to the destination by holding the bottom handles and the four installed handles.



#### NOTICE

When handling the inverter, do not remove the cushion to avoid damage to the housing or bottom terminals.

#### NOTICE

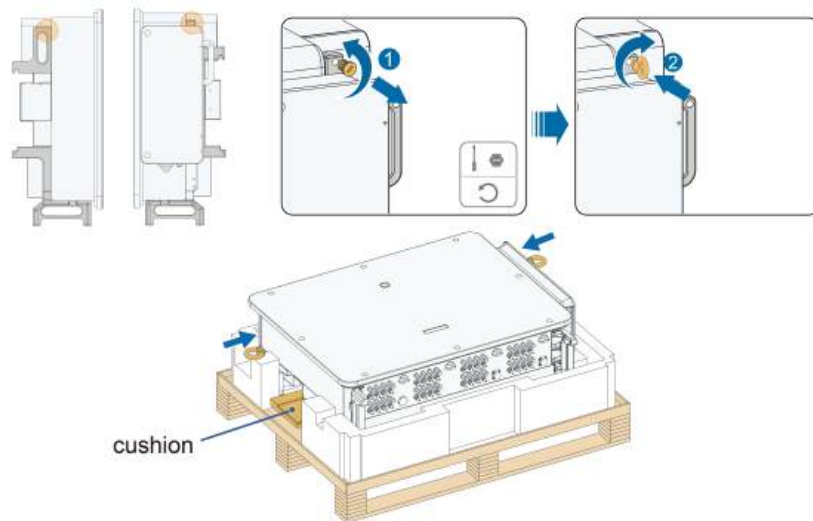
The screw-in handles are not packed together with the inverter. You can find them in the accessory package.

### 4.4.2 Hoisting Transport

table 4-2 Tools

Device Name	Requirement	Source
Crane	Load bearing capacity $\geq 180$ kg	Not included in the scope of delivery
Lifting ring	2, M12, load bearing capacity of a single ring $\geq 260$ kg	Not included in the scope of delivery
Sling	1, length $\geq 2.5$ m, load bearing capacity of a single sling $\geq 600$ kg	Not included in the scope of delivery

**step 1** Release the sealing screws on the mounting lugs and store them properly. Anchor two M12 thread lifting rings to the lugs of the inverter.

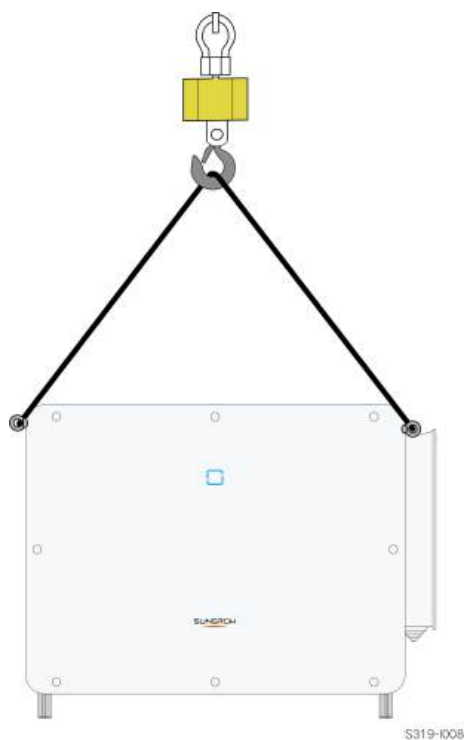


#### NOTICE

**When handling the inverter, do not remove the cushion to avoid damage to the housing or bottom terminals.**

**step 2** Lead the sling through the two lifting rings and fasten the tie-down strap.

**step 3** Hoist the inverter, and stop to check for safety when the inverter is 100 mm above the ground. Continue hoisting the device to the destination after ensuring the safety.



**step 4** Remove the lifting rings and reassemble the sealing screws released in Step 1.

#### **⚠ CAUTION**

Keep the inverter balanced throughout the hoisting process and avoid collisions with walls or other objects. Stop hoisting in the event of severe weather, such as heavy rain, thick fog, or strong wind.

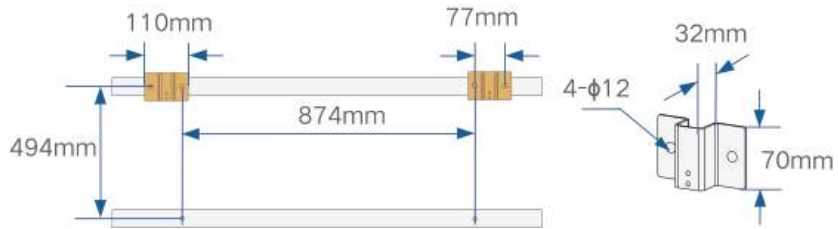


The lifting rings and the sling are not within the delivery scope.

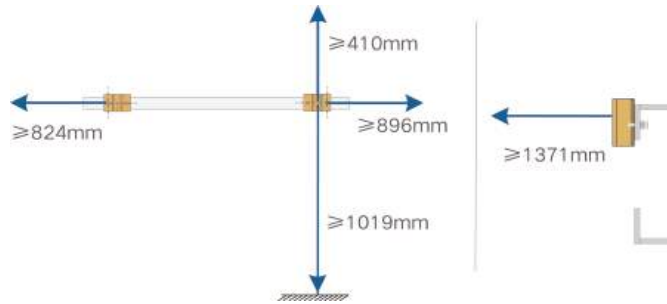
-- End

## 4.5 Installing Mounting-bracket

The inverter can be installed on a bracket, a wall, and a pole by means of mounting-bracket. Dimensions of the assembled mounting-bracket are as follows.



Reserve enough space when installing the mounting-bracket to meet the installation space requirements of the inverter.



### 4.5.1 Bracket-Mounted Installation

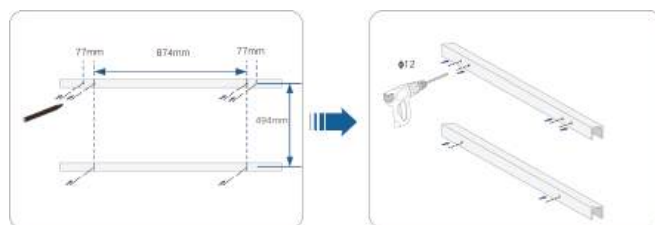
#### Tools

Item	Specification
Marker	-
Level	-
Electric drill	Drill bit: φ12
Wrench	Opening: 16 mm

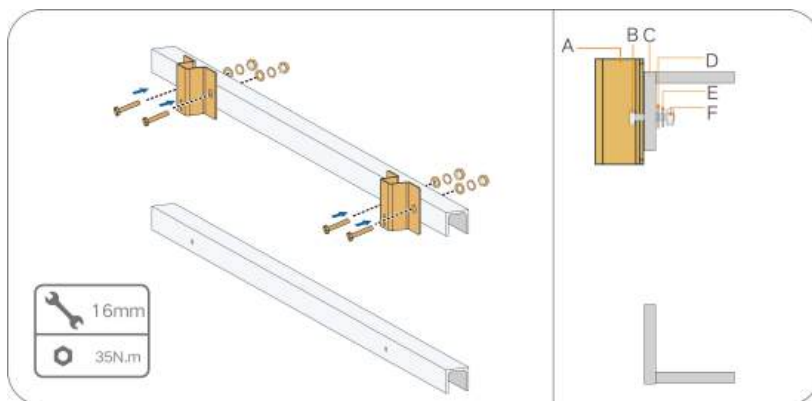
#### Spare parts

Item	Quantity	Specification	Source
Bolt assembly	4	M10	Delivery scope

**step 1** Place the assembled mounting-bracket onto the PV bracket. Adjust the angle with a level and mark positions for drilling holes. Drill the holes by using an electric drill.



**step 2** Secure the mounting-bracket with bolts.



(A) Mounting-bracket

(B) Full threaded bolt

(C) Metal bracket

(D) Flat washer

(E) Spring washer

(F) Hex nuts

-- End

## 4.5.2 Pole-Mounting

### Tools

Item	Specification
Marker	—
Level	—
Electric drill *	Drill bit: $\phi 12$
Wrench	Opening: 16 mm

\* Check whether other tools are needed according to the specification of clamp bolts.

### Spare parts

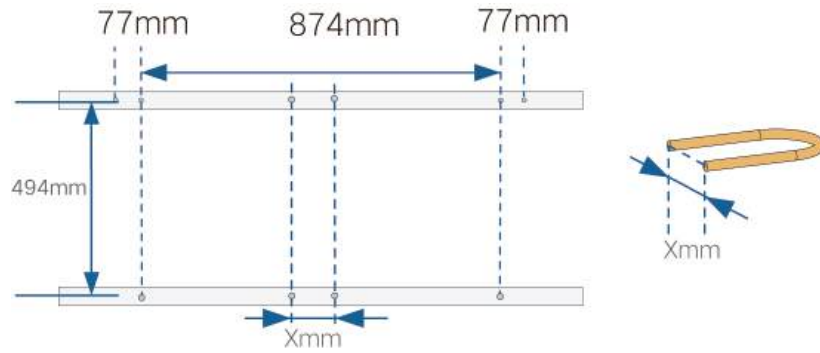
Item	Quantity	Specification	Source
Bolt assembly	4	M10	Delivery scope
Nut assembly	4	M10	Self-prepared
U-beam	2	—	Self-prepared
Clamp	2	Determined by pole size	Self-prepared

**step 1** Bury the pole into the installation site.

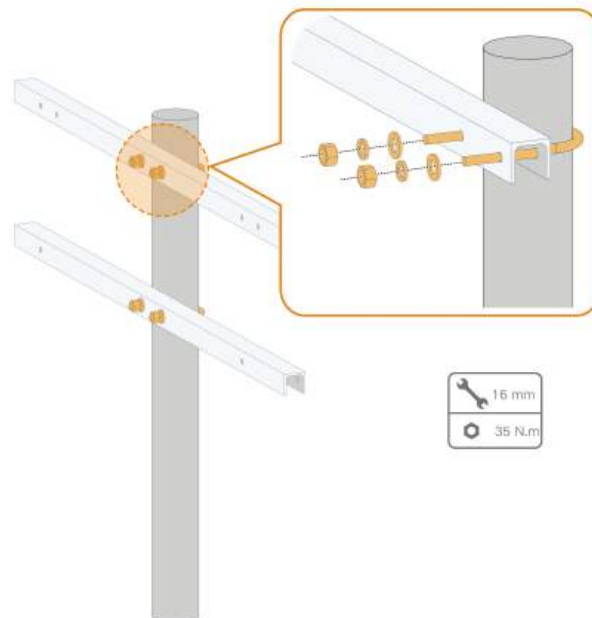


Please skip this step if the inverter is to be installed on a concrete post, PV bracket, etc.

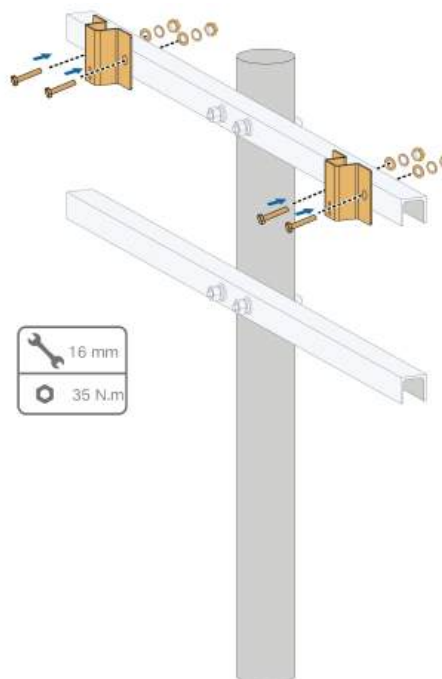
**step 2** Mark and punch holes in the U-beam according to the dimensions shown below.



**step 3** Use bolts and clamps to fix the U-beam to the pole.



**step 4** Use bolts to secure the mounting-bracket to the U-beam.



-- End

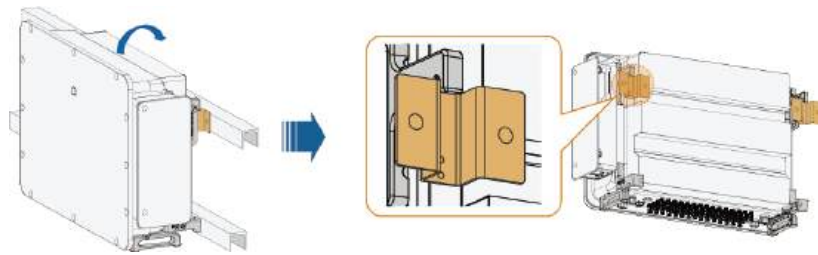
## 4.6 Installing the Inverter

### Spare parts

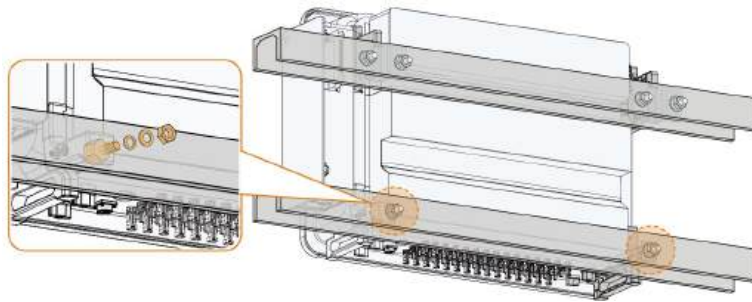
Item	Quantity	Specification	Source
Grub screw	2	M10	Delivery scope

**step 1** If the installation position is high, hoist the inverter to the position (refer to [4.4.2 Hoisting Transport](#)). Otherwise, skip this step.

**step 2** Remove the bottom cushion and lift the inverter onto the mounting-bracket. Make sure that the mounting lugs fit well into the grooves of the mounting-bracket.



**step 3** Fix the inverter with screws.



#### NOTICE

It is necessary to secure the left and right sides of the inverter to the mounting-bracket with screws, otherwise the inverter may become unstable.

-- End

# 5 Electrical Connection

## 5.1 Safety Instructions

### DANGER

The PV string will generate lethal high voltage when exposed to sunlight.

- Operators must wear proper personal protective equipment during electrical connections.
- Must ensure that cables are voltage-free with a measuring instrument before touching DC cables.
- Respect all safety instructions listed in relevant documents about PV strings.

### DANGER

- Before electrical connections, please make sure that the inverter switch and all switches connected to the inverter are set to "OFF", otherwise electric shock may occur!
- Ensure that the inverter is undamaged and all cables are voltage free before performing electrical work.
- Do not close the AC circuit breaker until the electrical connection is completed.

### WARNING

Damage to the product caused by incorrect wiring is not covered by the warranty.

- Electrical connection must be performed by professionals.
- Operators must wear proper personal protective equipment during electrical connections.
- All cables used in the PV generation system must be firmly attached, properly insulated, and adequately dimensioned. Cables used shall comply with the requirements of local laws and regulations.
- The factors that affect cable selection include rated current, cable type, routing mode, ambient temperature, and maximum expected line loss.

**⚠ WARNING**

- **Do not damage the ground conductor. Do not operate the product in the absence of a properly installed ground conductor. Otherwise, it may cause personal injury or product damage.**
- **Please use measuring devices with an appropriate range. Overvoltage can damage the measuring device and cause personal injury.**

**NOTICE**

**All electrical connections must comply with local and national/regional electrical standards.**

- **Cables used by the user shall comply with the requirements of local laws and regulations.**
- **Only with the permission of the national/regional grid department, the inverter can be connected to the grid.**

**NOTICE**

- **Install the external protective grounding cable first when performing electrical connection and remove the external protective grounding cable last when removing the inverter.**
- **Comply with the safety instructions related to PV strings and the regulations related to the utility grid.**

**NOTICE**

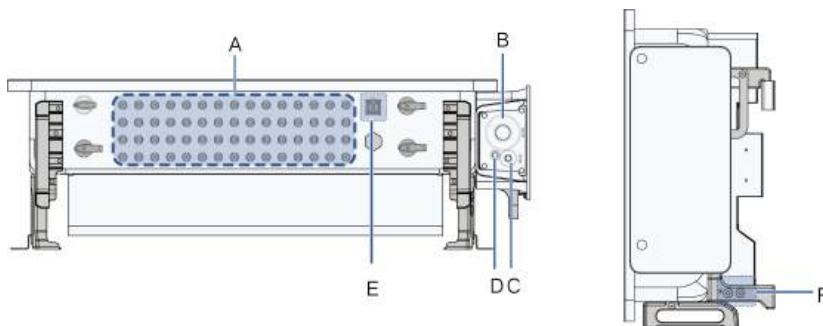
- After being crimped, the OT terminal must wrap the wires completely, and the wires must contact the OT terminal closely.
- When using a heat gun, protect the device from being scorched.
- Before connecting a power cable (such as the AC cable, the DC cable, etc.), confirm that the label and identifier on the power cable are correct.
- When laying out communication cables, separate them from power cables and keep them away from strong interference sources to prevent communication interruption.
- All vacant terminals must be covered with waterproof covers to prevent affecting the protection performance.
- Ensure that AC output cables are firmly connected. Failing to do so may cause inverter malfunction or damage to its AC connectors.
- When the wiring is completed, seal the gap at the cable inlet and outlet holes with fireproof/waterproof materials such as fireproof mud to prevent foreign matter or moisture from entering and affecting the long-term normal operation of the inverter.



The cable colors in figures in this manual are for reference only. Please select cables according to local cable standards.


## 5.2 Terminal Description

All electrical terminals are located at the side and bottom of the inverter.



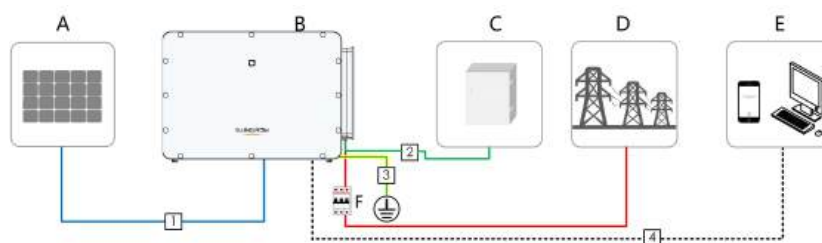
**figure 5-1** Terminal Description

\* The image shown here is for reference only. The actual product received may differ.

Item	Terminal	Mark	Note
A	PV terminals	+ / -	30/24, PV connector The number of PV terminals varies, subject to actual product received
B	AC wiring terminal	—	Used for AC output cable connection.
C	Standby grounding terminal	—	If the PE cable is an independent single-core cable, it should be led into the AC junction box for cable wiring through the standby grounding terminal
D	Tracker terminal	—	For the power cord wiring of the Tracking system
E	Communication terminal	COM1	For RS485 communication wiring.
G	External protective grounding terminal		For reliable grounding 2, use at least one of them to ground the inverter.

### 5.3 Electrical Connection Overview

Electrical connection in the PV system includes external grounding connection, AC connection, and PV string connection.



(A) PV string

(B) Inverter

(C) Tracking control box

(D) Grid

(E) Monitoring device

(F) AC circuit breaker

**table 5-1** Cable Requirements

No.	Cable	Type	Specification	
			Cable Diameter(mm)	Conductor Cross-sectional Area(mm <sup>2</sup> )
1	DC cable	PV cable complying with 1,500V standard	4.7 ~ 6.4	4 ~ 6
2	Tracking system power cable	Outdoor double-core copper wire cable	8 ~ 18	0.5 ~ 10 (Recommended 4 ~ 6)
3	External grounding cable	Outdoor single-core copper wire cable	/	$S_p \geq S/2$
4	AC cable	One Wire per Phase with Multi-core Cable	Refer to <a href="#">table 5-2 AC Cable Requirements (One Wire per Phase with Multi-core Cable)</a>	
		Two Wires per Phase with Multi-core Cable	Refer to <a href="#">table 5-3 AC Cable Requirements (Two Wires per Phase with Multi-core Cable)</a>	
5	Communication cable	Shielded twisted pair	4 ~ 11	0.75 ~ 1.5

Note: S is the cross-sectional area of the AC cable conductor, and  $S_p$  is the cross-sectional area of the ground cable conductor.

If single-core cables are used, whether one-wire per phase or two-wire per phase, the AC sealing plate is different. For details, please contact SUNGROW.

The AC cable sealing plate delivered with the inverter varies. The actual product received shall prevail. The sealing plate and the required AC cables are as follows.

**table 5-2** AC Cable Requirements (One Wire per Phase with Multi-core Cable)

No.	Type	Specification	
		Cable Diameter(mm)	Conductor Cross-sectional Area(mm <sup>2</sup> )
1	Outdoor four-core copper / aluminum wire cable <sup>(1)</sup>	Four-core cable: 40 ~ 75	Copper wire: S: 70 ~ 185
2	Outdoor three-core copper / aluminum wire cable <sup>(1)</sup>	Three-core cable: 40 ~ 75	$S_p \geq S/2$ Aluminum wire: S: 150 ~ 400
	Outdoor PE cable <sup>(2)</sup>	PE cable: 15 ~ 32	$S_p \geq S/2$

No.	Type	Specification	
		Cable Diameter(mm)	Conductor Cross-sectional Area(mm <sup>2</sup> )
3	Outdoor single-core copper / aluminum wire cable	18 ~ 40	

Note(1) A copper to aluminum adapter terminal is required when an aluminum cable is used. For details, refer to [Aluminum Cable Requirements](#).

Note(2) The specifications are valid only when the phase wire and PE wire use the same material. If otherwise, ensure that the cross section of the PE wire produces a conductance equivalent to that of the wire specified in the table.

Note(3) If the outdoor-type single-core cable is used as the AC cable, please prepare a sealing plate for the single-core cable separately. Contact SUNGROW if needed.

**table 5-3** AC Cable Requirements (Two Wires per Phase with Multi-core Cable)

No.	Type	Specification	
		Cable Diameter(mm)	Conductor Cross-sectional Area(mm <sup>2</sup> )
1	Outdoor four-core copper / aluminum wire cable <sup>(1)</sup>	Four-core cable: 47 ~ 59	Copper wire:
2	Outdoor three-core copper / aluminum wire cable <sup>(1)</sup>	Three-core cable: 47 ~ 59	S: 120 ~ 185 $S_p \geq S/2$
	Outdoor PE cable <sup>(2)</sup>	PE cable: 10~ 30	Aluminum wire: S: 120 ~ 185
3	Outdoor single-core copper / aluminum wire cable	18 ~ 30	$S_p \geq S/2$

Note(1) A copper to aluminum adapter terminal is required when an aluminum cable is used. For details, refer to [Aluminum Cable Requirements](#).

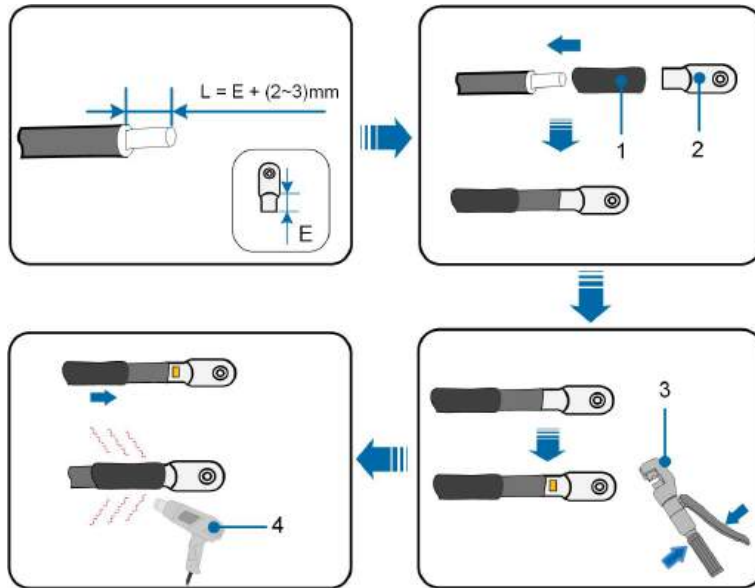
Note(2) The specifications are valid only when the phase wire and PE wire use the same material. If otherwise, ensure that the cross section of the PE wire produces a conductance equivalent to that of the wire specified in the table.



If the SUNGROW MVS is used, please refer to the cable requirements specified in the MVS user manual first.

## 5.4 Crimp OT/DT terminal

### Crimp OT/DT terminal



- 1. Heat shrink tubing
- 3. Hydraulic pliers

- 2. OT/DT terminal
- 4. Heat gun

### Aluminum Cable Requirements

If an Aluminum cable is selected, use a copper to Aluminum adapter terminal to avoid direct contact between the copper bar and the Aluminum cable.

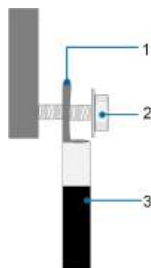


figure 5-2 Aluminum Cable Connection

- 1. Copper to Aluminum adapter terminal

- 2. Flange nut

- 3. Aluminum cable

**NOTICE**

Ensure that the selected terminal can directly contact with the copper bar. If there are any problems, contact the terminal manufacturer.

Ensure that the copper bar is not in direct contact with the aluminum wire. Otherwise, electrochemical corrosion may occur, impairing the reliability of electrical connection.

## 5.5 External Protective Grounding Connection

**⚠ DANGER**

Electric shock!

- Make sure that the grounding cable is connected reliably. Otherwise, it may cause electric shock.

**⚠ WARNING**

- Since the inverter is not equipped with a transformer, neither the negative electrode nor the positive electrode of the PV string can be grounded. Otherwise, the inverter will not operate normally.
- Connect the grounding terminal to the external protective grounding point before AC cable connection, PV string connection, and communication cable connection.
- The external protective grounding point provides a reliable ground connection. Do not use an improper grounding conductor for grounding. Otherwise, it may cause product damage or personal injury.
- Depending on Local Rules, please also ground the PV panel subconstruction to the same common grounding point (PE Bar) in addition to local lightning protection rules.

**⚠ WARNING**

It is suggested that the external protective grounding terminal and the AC side grounding terminal are both connected to ground. Other grounding schemes, which meet the local standards and safety regulations, may also be adopted. However, SUNGROW shall not be held liable for any consequence caused thereby.

### 5.5.1 External Protective Grounding Requirements

All non-current carrying metal parts and device enclosures in the PV power system should be grounded, for example, brackets of PV modules and inverter enclosure.

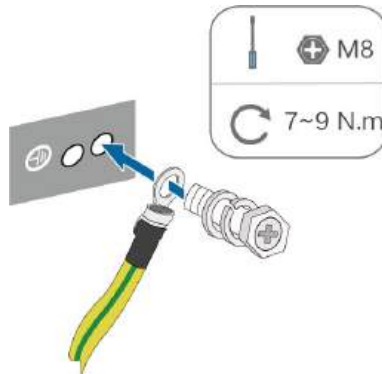
When there is only one inverter in the PV system, connect the external protective grounding cable to a nearby grounding point.

When there are multiple inverters in the PV system, connect the external protective grounding terminals of all inverters and the grounding points of the PV module brackets to ensure equipotential connections to ground cables (according to the onsite conditions).

### 5.5.2 Connection Procedure

**step 1** Prepare the cable and OT/DT terminal, refer to [Crimp OT/DT terminal](#).

**step 2** Remove the screw on the grounding terminal and fasten the cable with a screwdriver.



**step 3** Apply paint to the grounding terminal to ensure corrosion resistance.



The grounding screws have been anchored to the side of the inverter before delivery, and do not need to be prepared.  
There are two grounding terminals. Use one of them to ground the inverter.

-- End

## 5.6 AC Cable Connection

### 5.6.1 AC Side Requirements



Only with the permission of the local grid department, the inverter can be connected to the grid.

Before connecting the inverter to the grid, ensure the grid voltage and frequency comply with requirements, for which, refer to "**Technical Data**". Otherwise, contact the electric power company for help.

## AC Circuit Breaker

### WARNING

Over-current protection devices, such as AC circuit breakers and fuses, must be installed on the AC side of the inverter and the grid side to ensure safe disconnection between the inverter and the grid.

- Do not connect any local load between the inverter and the AC circuit breaker except for the tracking axis.
- Multiple inverters cannot share one AC circuit breaker.

**table 5-4** Recommended Specifications of AC Circuit Breaker

Inverter Model	Recommended Rated Voltage	Recommended Rated Current
SG305HX/SG320HX-20/ SG350HX-20	800 V	350A / 400A

## Multiple Inverters in Parallel Connection

When multiple inverters are connected to the grid in parallel, ensure that the maximum number of inverters connected in parallel to a single winding of the box-type substation is 15. Otherwise, please contact SUNGROW for technical scheme.

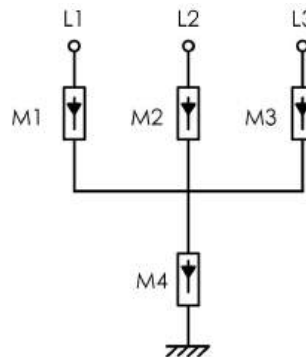
## MV Transformer

The MV transformer used together with the inverter should meet the following requirements:

- A distribution transformer can be used if it is designed for the typical cyclical loads of a PV system (there is load in the day and no load at night).
- A liquid-immersed type transformer or a dry type transformer can be used, and the shield winding is not a requisite.
- The line-to-line voltage on the LV side of the transformer should endure the output voltage of inverter. When the transformer is connected to the IT grid, to-ground withstanding voltage of the LV winding of the transformer, the LV side AC cables, and the LV side secondary equipment (including the relay protection device, detection & measuring device, and other related auxiliary devices) should not be lower than 906V.
- The line-to-line voltage on the HV side of the transformer should comply with the local power grid voltage.
- A transformer with a tap changer on the HV side is recommended in order to keep the voltage consistent with the grid voltage.
- At an ambient temperature of 30°C, the transformer can run in 1.1 times of load for a long time.
- The voltage drop of system cable is no more than 3%.

- The DC component that the transformer can withstand is 1% of the fundamental current at rated power.
- For thermal rating, the load curve of the transformer and environment conditions should be taken into account.
- The apparent power of the inverter should never exceed the power of the transformer. The maximum AC current of all inverters connected in parallel must be taken into account. If more than 15 inverters are connected to the grid, contact SUNGROW.
- The transformer must be protected against overloading and short circuit.
- The transformer is an important part of grid-connected PV generation system. The fault tolerance capacity of the transformer should be taken into account at all times. The fault include: system short circuit, grounding fault, voltage drop, etc.
- Take ambient temperature, relative humidity, altitude, air quality, and other environmental conditions into account when selecting and installing the transformer.
- The overall technical requirements of the box-type LV cabinet are as follows:
  - The breaking capacity of the branch molded case circuit breaker (MCCB) and air circuit breaker (ACB) of the box-type LV cabinet should be greater than the short circuit current at the LV side of the transformer. For example, the LV side short-circuit current of a boost transformer with a rated capacity of 3200 kVA and a short-circuit resistance of 7% can be calculated in the following way:  $I=3200/0.8/1.732/0.07/0.9=36.66\text{kA}$ . Thus the MCCB Icu of the LV cabinet branch circuit should be no less than 36.66 kA at 880Vac. The LV side short-circuit current of a boost transformer with a rated capacity of 4480kVA and a short-circuit impedance of 8% can be calculated in the following way:  $I=4480/0.8/1.732/0.08/0.9=44.91\text{kA}$ . Thus the MCCB Icu of the LV cabinet branch circuit should be no less than 44.91kA at 880Vac.
  - The temperature and altitude derating should be taken into account when a circuit breaker is working, and a LV cabinet temperature rise test report is required.
  - When designing a LV cabinet, must pay attention to the impact of the diffused MCCB electric arc on the cabinet and other branch circuit MCCBs, thus the interior of the cabinet needs to be insulated. A third-party test report of the circuit-breaking performance of the whole machine in an event of a short-circuit on the LV side is also required. It is recommended to adopt graduated protection to ensure that in an event of a single short-circuit fault on the LV side of the box, the corresponding branch MCCB trips normally while the general ACB does not trip.
  - If PLC communication is adopted, reserve a fuse-switch disconnecter or circuit breaker inside the LV power distribution room of the box-type transformer. For the connection to the EMU200 communication box, it is recommended to use the outdoor-type UV-resistant multi-core copper AC cable with a core diameter of 2.5mm<sup>2</sup> or above and an insulation voltage of > 1000V. The PLC cable connecting the EMU200 to the LV bus of the box-type transformer should be < 10m.

- When Anti-PID is enabled, the AC output common mode voltage of the inverter is 906V, and the following requirements should be met:
  - The LV side winding of the transformer, AC cables, and secondary devices (including protective relay, detection and measurement instruments, and related auxiliary devices) must withstand the voltage to ground of at least 906 V.
  - If the LV side winding is in Y shape, neutral point grounding is prohibited.
  - Surge protective devices (SPD) for the AC combiner box and on the LV side of the transformer are recommended to be connected in the "3+1" manner, as shown in the figure below. The Min. continuous operating voltages of M1 - M4 are 680 Vac.



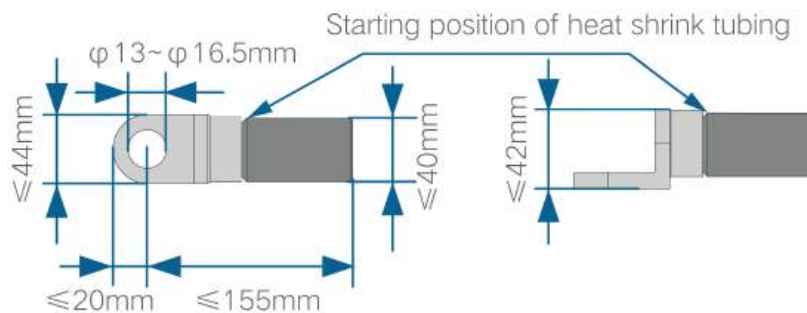
- The string serial communication box EMU200A requires an external power supply of 220 Vac, so a power supply port and an input port (including switches) should be reserved in the LV power distribution room of the boost transformer.

### 5.6.2 Requirements for OT/DT Terminal

OT/DT terminals (not included in the delivery scope) are required for fixing AC cables to the terminal block. Purchase the OT/DT terminals according to the following requirements.

#### OT/DT Terminals of Phase Wire (One Wire per Phase with Multi-core Cable)

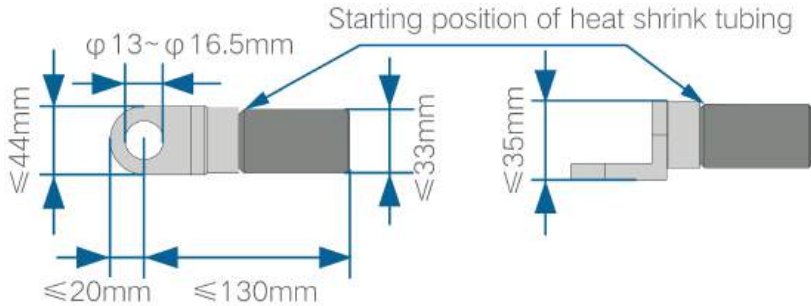
- Specification: M12



S325-E032

### OT/DT Terminals of Phase Wire (Two Wires per Phase with Multi-core Cable)

- Specification: M12



S325-E033

### OT/DT Terminal of PE Wire

- Specification: M12

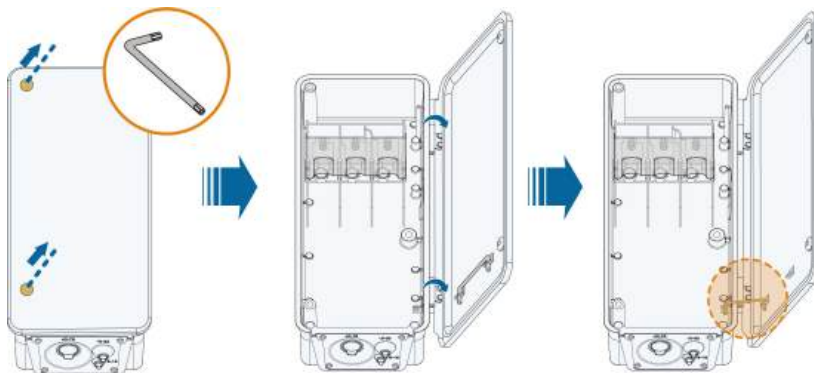
#### 5.6.3 One-wire-per-phase Wiring (with Multi-core Cable)



This section introduces the connection steps with four-core cable as an example, and the wiring method for three-core cable is the same.

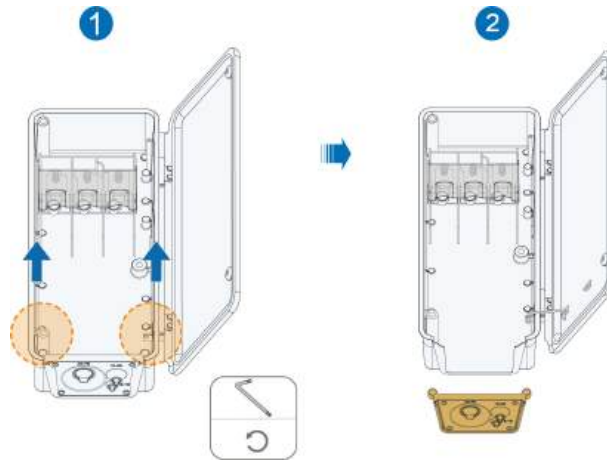
**step 1** Open the AC-side circuit breaker and prevent it from closing inadvertently.

**step 2** Loosen the two screws on the front cover of the junction box with the hexagon socket wrench provided. Open the junction box. During the wiring process, the limit rod attached to the cover keeps the junction box open.



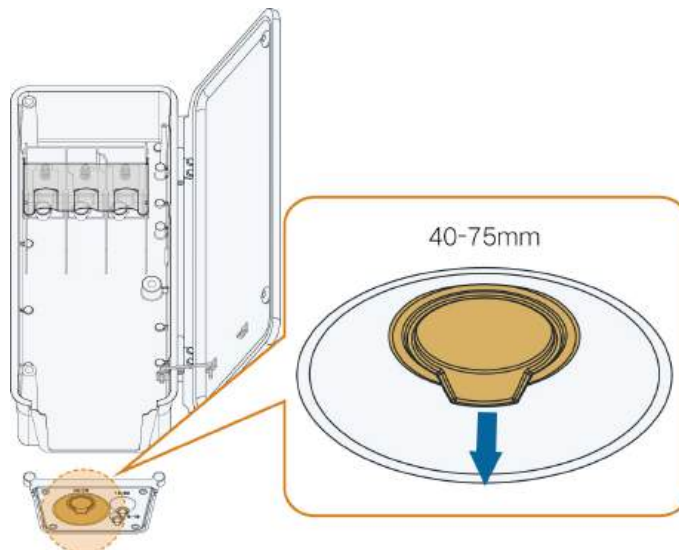
The screws on the front cover of the junction box are captive screws, which will remain on the front cover when the cover is open to avoid screw loss.

**step 3** Loosen the screws on the bottom sealing plate with the hexagon socket wrench provided and remove the bottom sealing plate.

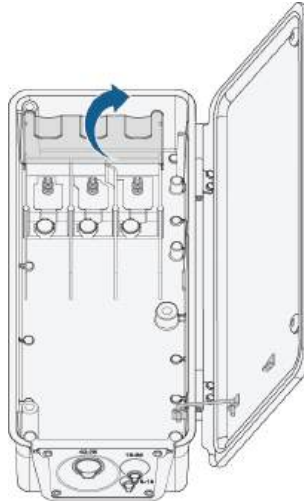


The screws on the sealing plate are captive screws, which will remain on the sealing plate when the sealing plate is removed to avoid screw loss.

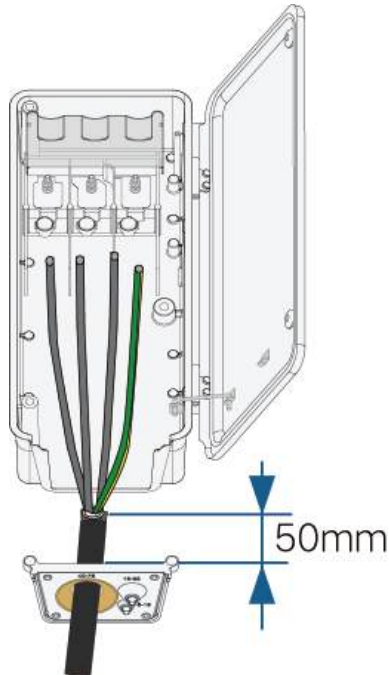
**step 4** Peel off the tear-off tab at the bottom of the sealing plate.



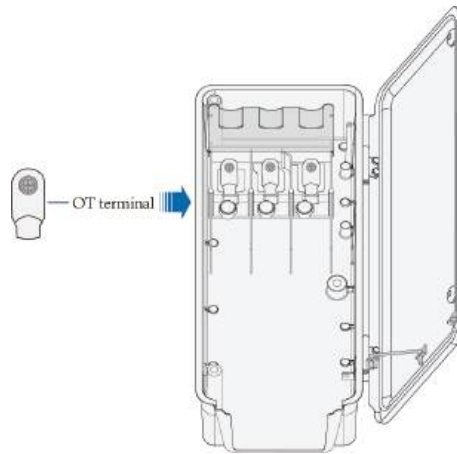
**step 5** Open the protection cover.



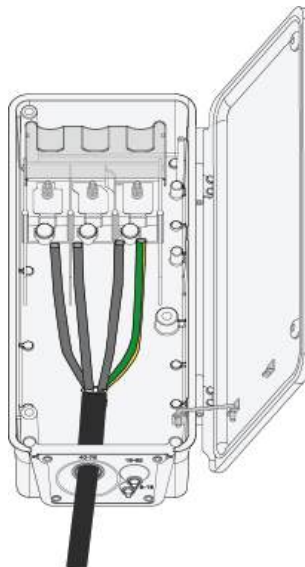
**step 6** Strip the external protective layer of the AC cable. A length of at least 50mm above the bottom sealing plate in the cable should be left intact, without being stripped.



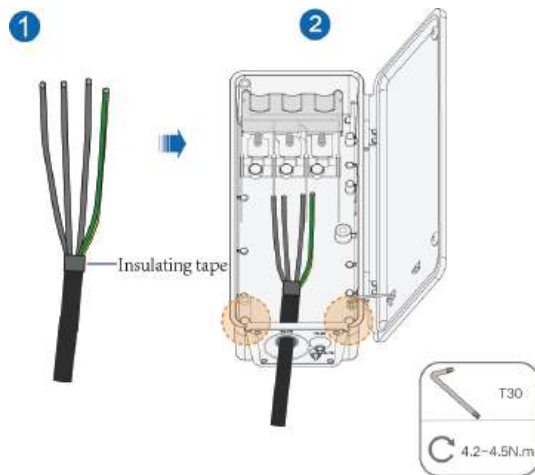
**step 7** Hang the OT terminals on the corresponding wiring terminals in the junction box.



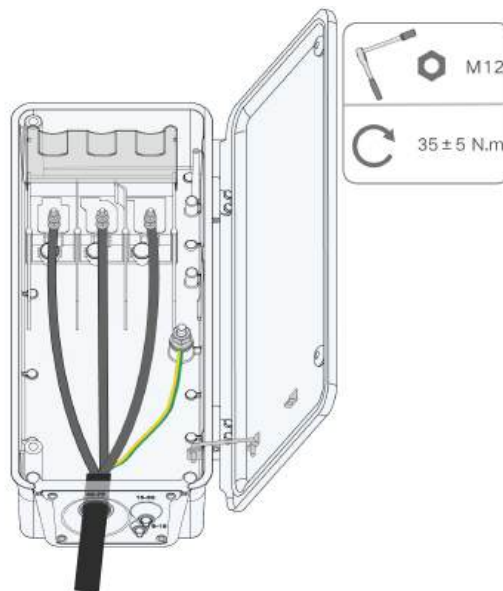
**step 8** Pass the AC cable through the bottom sealing plate, and put the AC cable and bottom sealing plate into the junction box. For ease of OT/DT terminal crimping, make sure the cable inside the junction box is long enough.



**step 9** Smooth the cut edge of the cable. Next, wrap it with insulating tape, and then fit the three-branch breakout boot and cold-/heat-shrink tubing. After that, fasten the screws on the bottom sealing plate. The three-branch breakout boot and cold-/heat-shrink tubing should be prepared by users separately and their specifications should match the requirements of the cable used.

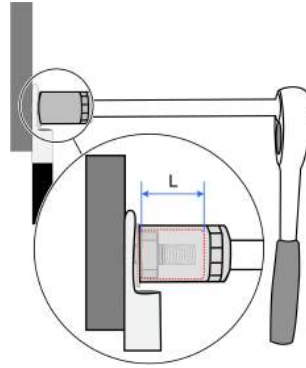


**step 10** Crimp the OT/DT terminals onto the wires. Then, secure the wires to the corresponding terminals, at a torque of 30–40N.m, as specified on the label inside the AC junction box. Securing terminals at a torque smaller or greater than the specified value may lead to poor connection.

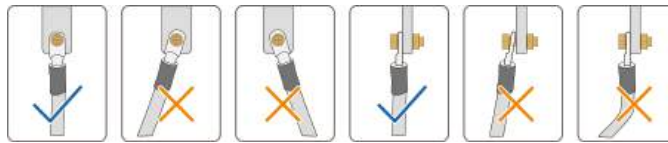




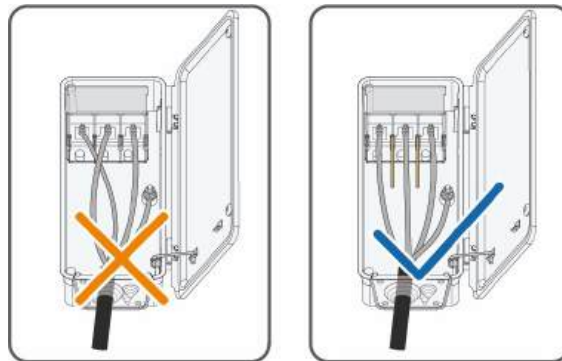
- Ensure that the inner depth L of the socket used is not less than 28mm.



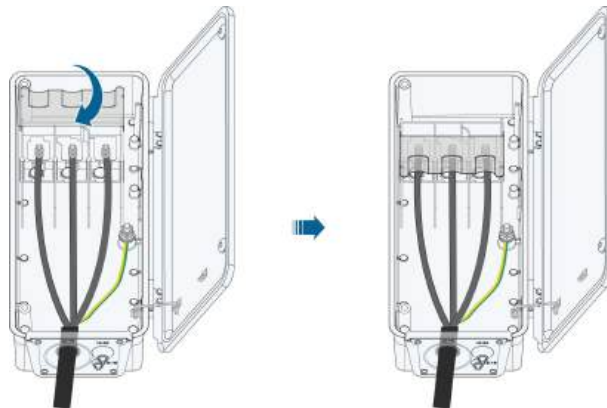
- When securing the wires to the corresponding terminals, make sure the wires do not lean forward, backward, leftward, or rightward.



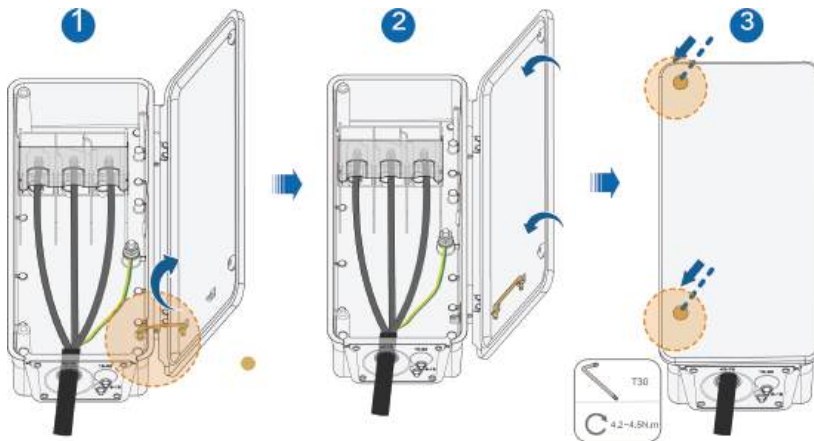
- Do not cross the wires.



**step 11** Close the protection cover.

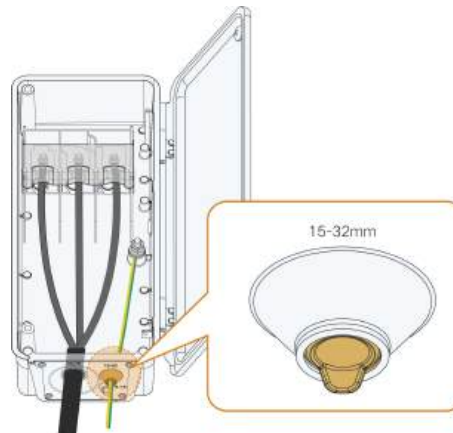


**step 12** Remove the limit rod and place it in place. Close the junction box and tighten the two screws on its front cover with the hexagon socket wrench provided.



-- End

When a separate single-core cable is used as the PE cable, lead it into the junction box through the standby grounding terminal.

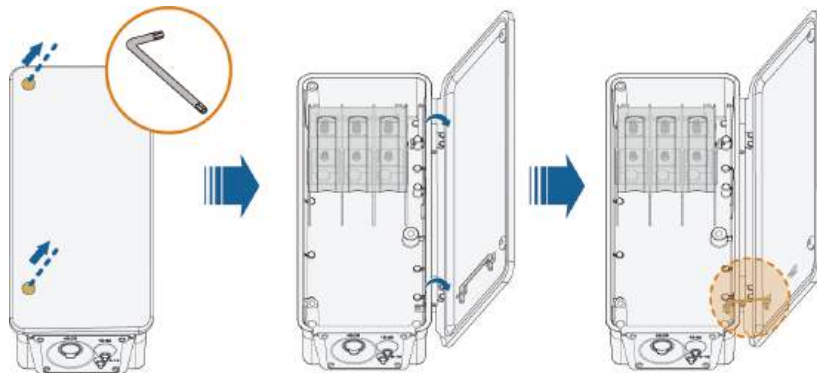


#### 5.6.4 One-wire-per-phase Wiring, Duplex Junction Box (with Multi-core Cable)

**i** Only some of the inverters support the two-wire-per-phase connection. Please contact SUNGROW if you have any questions.

**step 1** Open the AC-side circuit breaker and prevent it from closing inadvertently.

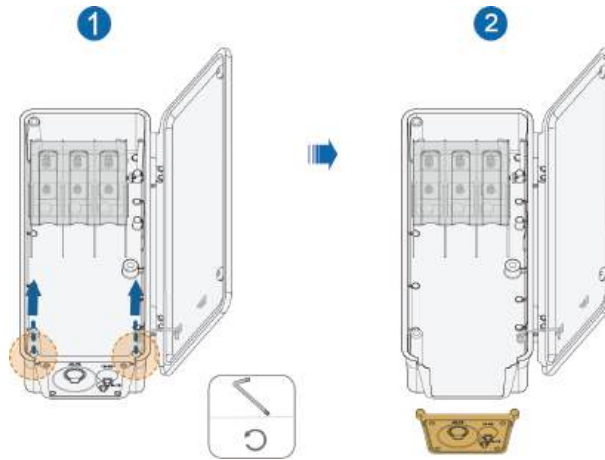
**step 2** Loosen the two screws on the front cover of the junction box with the hexagon socket wrench provided. Open the junction box. During the wiring process, the limit rod attached to the cover keeps the junction box open.



**i** The screws on the front cover of the junction box are captive screws, which will remain on the front cover when the cover is open to avoid screw loss.

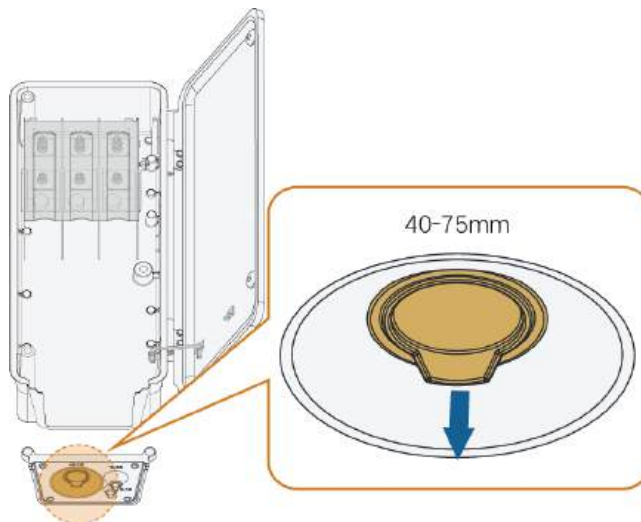
**i** If the one-wire-per-phase connection is adopted for a duplex-junction-box inverter, please make sure the wires of the cable are connected to terminals in the same row without crossing.

**step 3** Loosen the screws on the bottom sealing plate with the hexagon socket wrench provided and remove the bottom sealing plate.

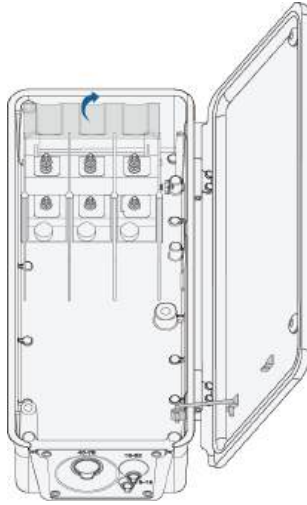


**i** The screws on the sealing plate are captive screws, which will remain on the sealing plate when the sealing plate is removed to avoid screw loss.

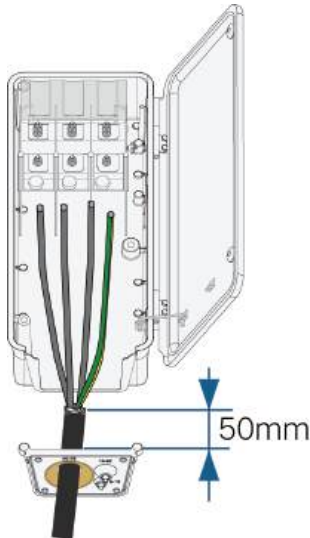
**step 4** Peel off the tear-off tab on the sealing plate.



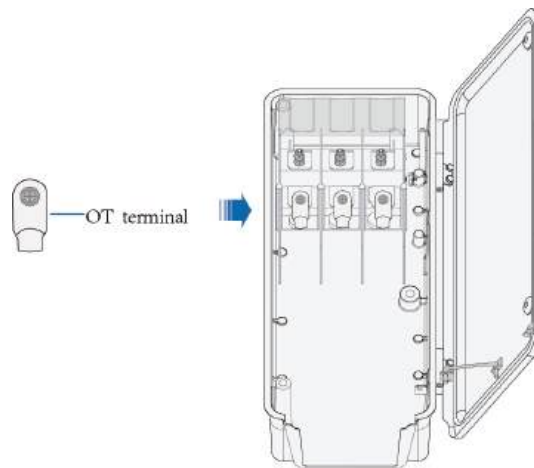
**step 5** Open the protection cover.



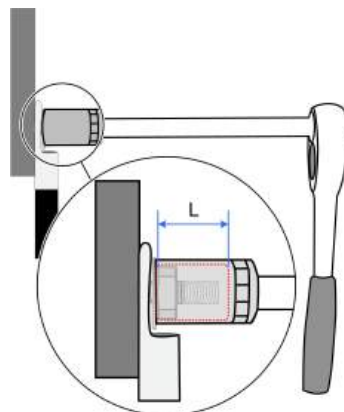
**step 6** Strip the external protective layer of the AC cable. A length of at least 50mm above the bottom sealing plate in the cable should be left intact, without being stripped.



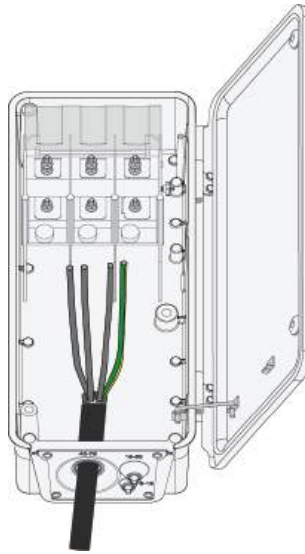
**step 7** Hang the OT terminals on the corresponding wiring terminals in the junction box.



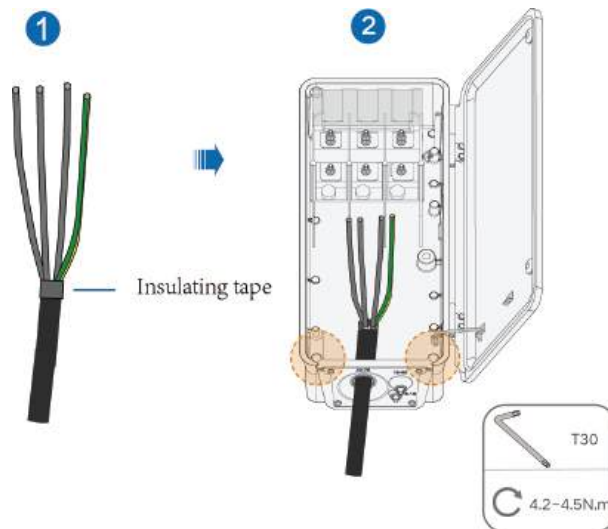
Ensure that the inner depth  $L$  of the socket used is not less than 28 mm.



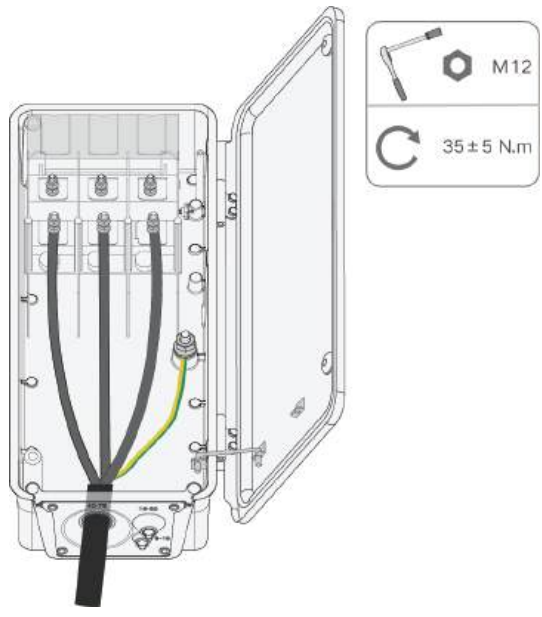
**step 8** Pass the AC cable through the bottom sealing plate, and put the AC cable and bottom sealing plate into the junction box. For ease of OT/DT terminal crimping, make sure the cable inside the junction box is long enough.



**step 9** Smooth the cut edge of the cable. Next, wrap it with insulating tape, and then fit the three-branch breakout boot and cold-/heat-shrink tubing. After that, fasten the screws on the bottom sealing plate. The three-branch breakout boot and cold-/heat-shrink tubing should be prepared by users separately and their specifications should match the requirements of the cable used.

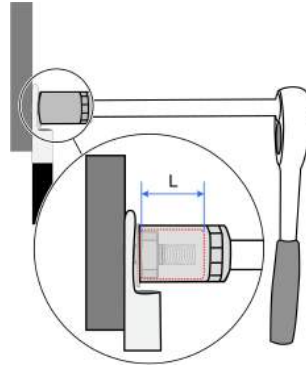


**step 10** Crimp the OT/DT terminals onto the wires. Then, secure the wires to the corresponding terminals, at a torque of 30–40N.m, as specified on the label inside the AC junction box. Securing terminals at a torque smaller or greater than the specified value may lead to poor connection.

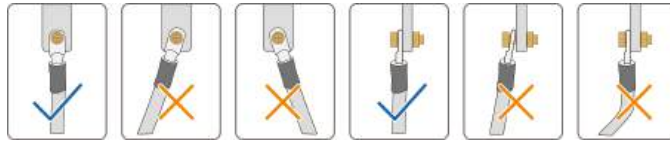




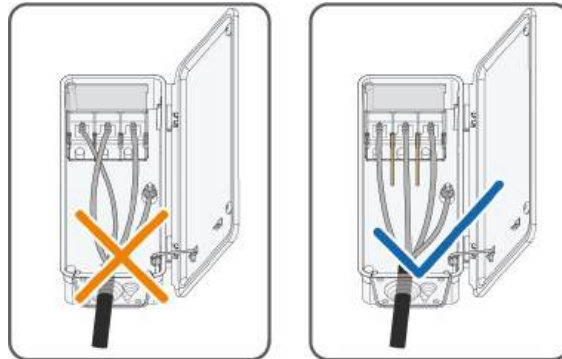
- Ensure that the inner depth L of the socket used is not less than 28mm.



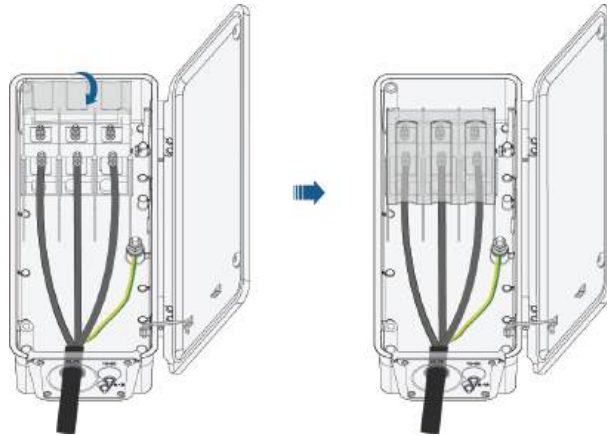
- When securing the wires to the corresponding terminals, make sure the wires do not lean forward, backward, leftward, or rightward.



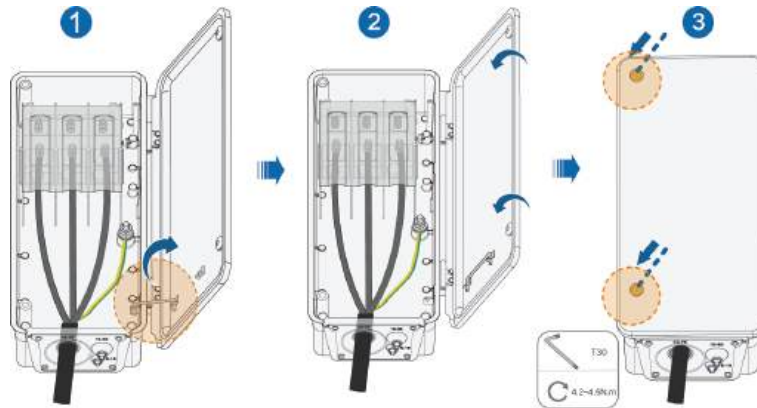
- Do not cross the wires.



**step 11** Close the protection cover.

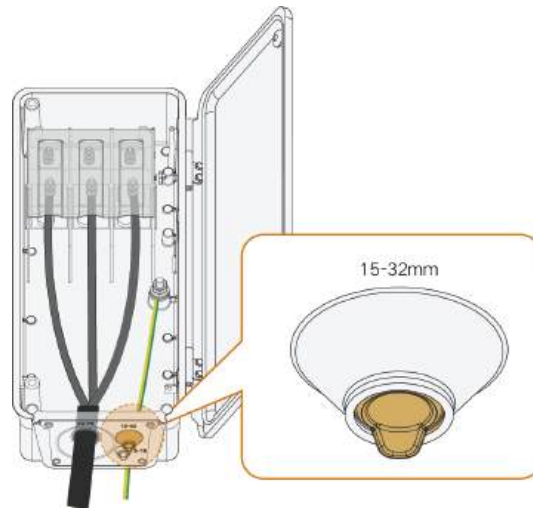


**step 12** Remove the limit rod and place it in place. Close the junction box and tighten the two screws on its front cover with the hexagon socket wrench provided.



-- End

When a separate single-core cable is used as the PE cable, lead it into the junction box through the standby grounding terminal.



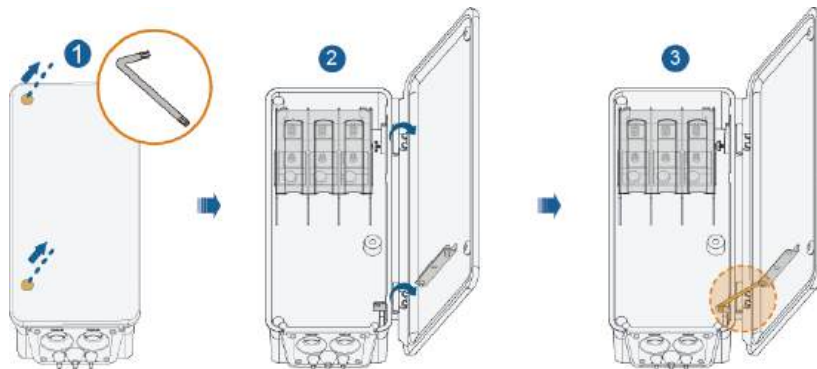
### 5.6.5 Two-wires-per-phase Wiring, Duplex Junction Box (with Multi-core Cable)



Only some of the inverters support the two-wire-per-phase connection. Please contact SUNGROW if you have any questions.

**step 1** Open the AC-side circuit breaker and prevent it from closing inadvertently.

**step 2** Loosen the two screws on the front cover of the junction box with the hexagon socket wrench provided. Open the junction box. During the wiring process, the limit rod attached to the cover keeps the junction box open.

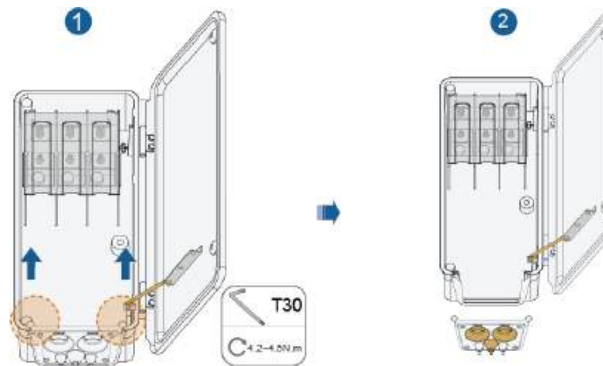


The screws on the front cover of the junction box are captive screws, which will remain on the front cover when the cover is open to avoid screw loss.



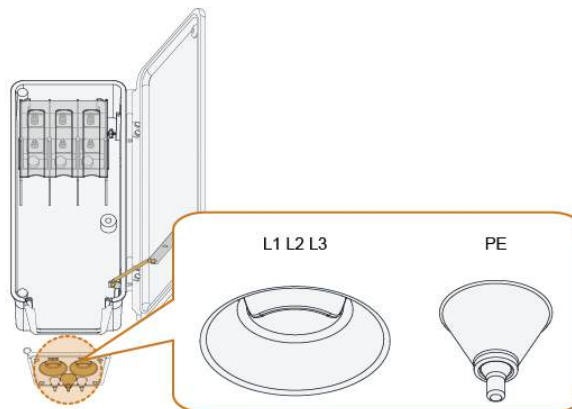
- If the two-wire-each-phase connection is adopted for a duplex-junction-box inverter, please make sure the wires of the two cables are connected respectively to the corresponding phase using terminals in the same column.
- If the two-wire-each-phase connection is adopted for a duplex-junction-box inverter: Connect wires to terminals in the bottom row first, and then to those in the upper row.
- If the one-wire-per-phase connection is adopted for a duplex-junction-box inverter, please make sure the wires of the cable are connected to terminals in the same row without crossing.

**step 3** Loosen the screws on the bottom sealing plate with the hexagon socket wrench provided and remove the bottom sealing plate.

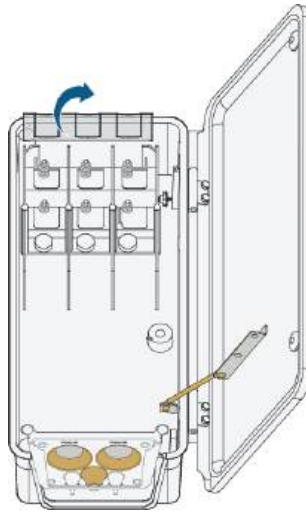


The screws on the sealing plate are captive screws, which will remain on the sealing plate when the sealing plate is removed to avoid screw loss.

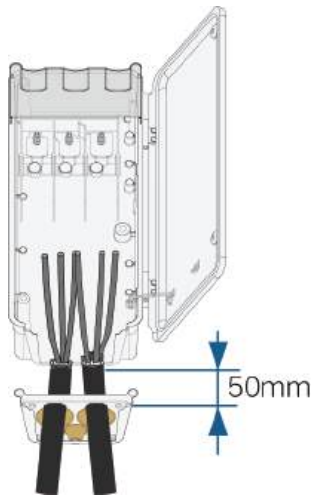
**step 4** Peel off the tear-off tab on the sealing plate.



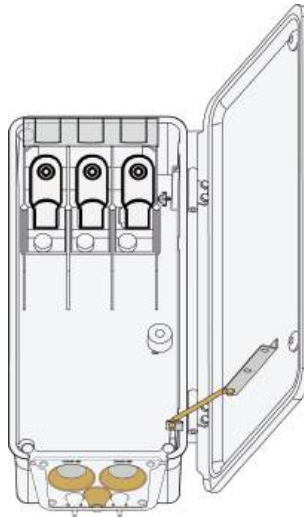
**step 5** Open the protection cover.



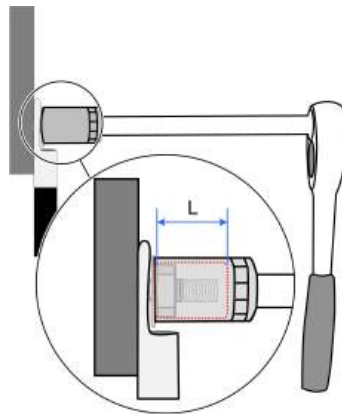
**step 6** Strip the external protective layer of the AC cable. A length of at least 50mm above the bottom sealing plate in the cable should be left intact, without being stripped.



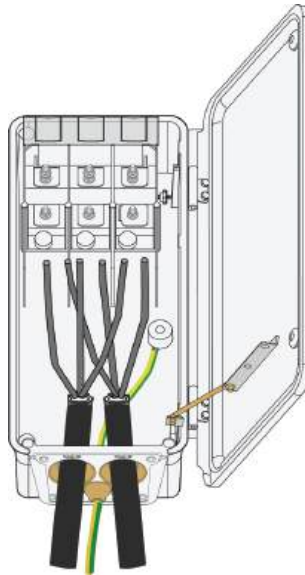
**step 7** Hang the OT terminals on the corresponding wiring terminals in the junction box.



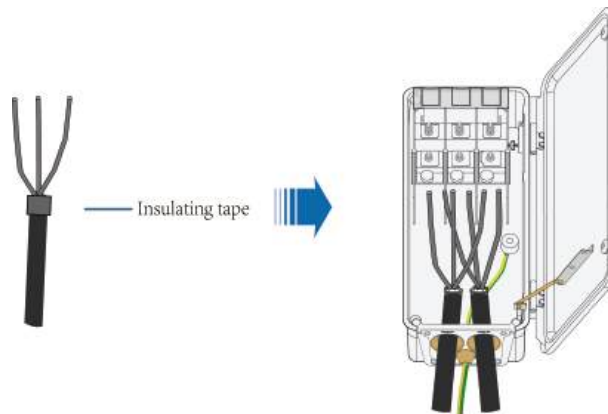
Ensure that the inner depth  $L$  of the socket used is not less than 28 mm.



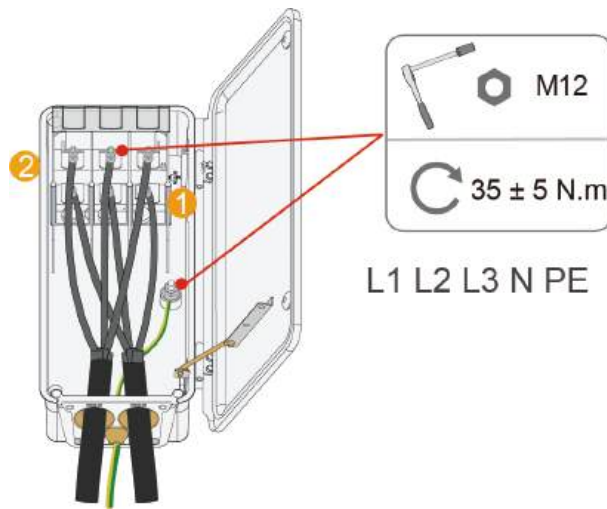
**step 8** Pass the AC cable through the bottom sealing plate, and put the AC cable and bottom sealing plate into the junction box. For ease of OT/DT terminal crimping, make sure the cable inside the junction box is long enough.



**step 9** Smooth the cut edge of the cable. Next, wrap it with insulating tape, and then fit the three-branch breakout boot and cold-/heat-shrink tubing. After that, fasten the screws on the bottom sealing plate. The three-branch breakout boot and cold-/heat-shrink tubing should be prepared by users separately and their specifications should match the requirements of the cable used.

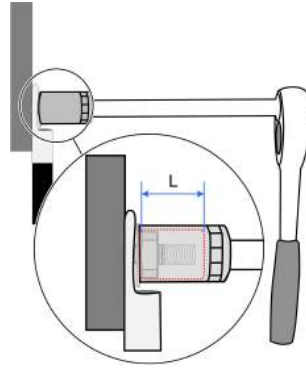


**step 10** Crimp the OT/DT terminals onto the wires. Then, secure the wires to the corresponding terminals, at a torque of 30–40N.m, as specified on the label inside the AC junction box. Securing terminals at a torque smaller or greater than the specified value may lead to poor connection. When wiring, make sure wires are connected to the terminals in the lower row first, and then to those in the upper row.

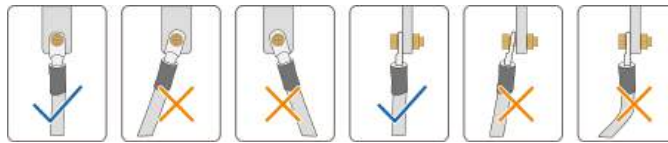




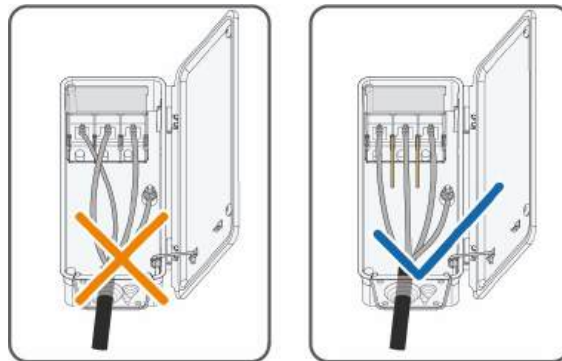
- Ensure that the inner depth L of the socket used is not less than 28mm.



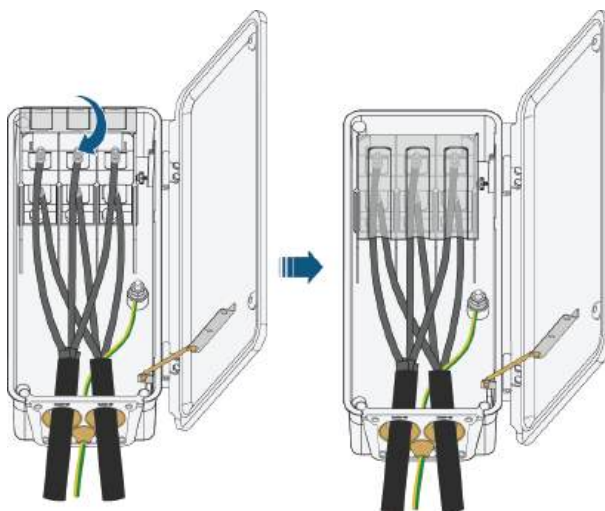
- When securing the wires to the corresponding terminals, make sure the wires do not lean forward, backward, leftward, or rightward.



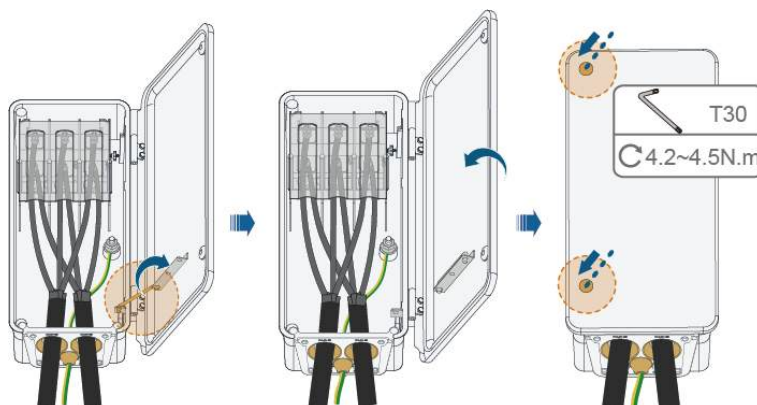
- Do not cross the wires.



**step 11** Close the protection cover.



**step 12** Remove the limit rod and place it in place. Close the junction box and tighten the two screws on its front cover with the hexagon socket wrench provided.



**step 13**

-- End

## 5.7 DC Cable Connection

### **⚠ DANGER**

The PV string will generate lethal high voltage when exposed to sunlight.

- Respect all safety instructions listed in relevant documents about PV strings.

**⚠ WARNING**

- **Make sure the PV array is well insulated to ground before connecting it to the inverter.**
- **Make sure the maximum DC voltage and the maximum short circuit current of any string never exceed inverter permitted values specified in "Technical Data".**
- **Check the positive and negative polarity of the PV strings, and connect the PV connectors to corresponding terminals only after ensuring polarity correctness.**
- **During the installation and operation of the inverter, please ensure that the positive or negative electrodes of PV strings do not short-circuit to the ground. Otherwise, an AC or DC short-circuit may occur, resulting in equipment damage. The damage caused by this is not covered by the warranty.**
- **Electric arc or contactor over-temperature may occur if the DC connectors are not firmly in place, and the loss caused is not covered by the warranty.**
- **If the DC input cables are reversely connected or the positive and negative terminals of different MPPT are shorted to ground at the same time, while the DC switch is in the "ON" position, do not operate immediately. Otherwise, the inverter may be damaged. Please turn the DC switch to "OFF" and remove the DC connector to adjust the polarity of the strings when the string current is lower than 0.5 A.**
- **Use the DC connectors supplied with the product for DC cable connection. Using incompatible DC connectors may result in serious consequences, and the device damage is not covered under warranty.**
- **Inverters do not support full parallel connection of strings (Full parallel connection refers to a connection method in that strings are connected in parallel and then connected to the inverter separately).**
- **Do not connect one PV string to multiple inverters. Otherwise, the inverters may be damaged.**
- **If AC wiring is to be performed when the inverter is connected to the grid, ensure the DC switches are set to "OFF" to guarantee the construction safety.**

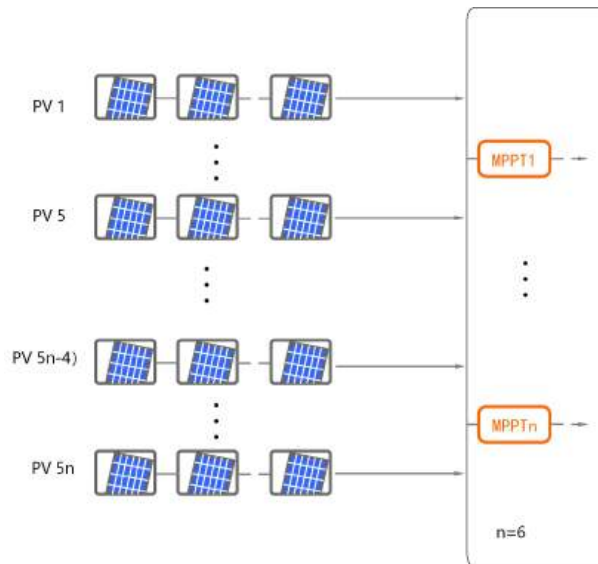
**NOTICE**

The following requirements about PV string connection must be met. Otherwise, it may cause irreversible damage to the inverter, which is not covered by the warranty.

- **Mixed use of PV modules of different brands or models in one MPPT circuit, or PV modules of different orientation or inclination in a string may not damage inverter, but will cause system bad performance!**

### 5.7.1 PV Input Configuration

- As shown in the figure below, the inverter is provided with multiple PV inputs, each PV input is designed with an MPP tracker.
- Each PV input operates independently and has its own MPPT. In this way, string structures of each PV input may differ from each other, including number of PV modules in each string, angle of tilt, and installation orientation.
- Each PV input includes five PV strings. In order to fully utilize the input power of PV panels, the PV strings of each PV input should have the same structure, including the same type, the same number, the same tilt, and the same orientation.



**figure 5-3** PV Input Configuratinon

Before connecting PV inputs to the inverter, please ensure that the strings in each input meet the following requirements:

- The maximum open circuit voltage of strings does not exceed 1500V DC.
- The maximum allowable operating current of strings is 25A.
- In non-operating scenarios, the withstand current of strings is 27A.

#### Terminal Configuration Description

Please refer to the following requirements for PV terminal connection:

- Y-type PV connectors cannot be used on this inverter.
- The PV1 terminal must be used for connection.

- Make sure the PV terminals connected are relatively evenly distributed across the MPPTs.
- While performing connection, please give priority to terminals in the white areas. If terminals in the white areas are all connected, connect the terminals in the black areas, as shown in the figure below.

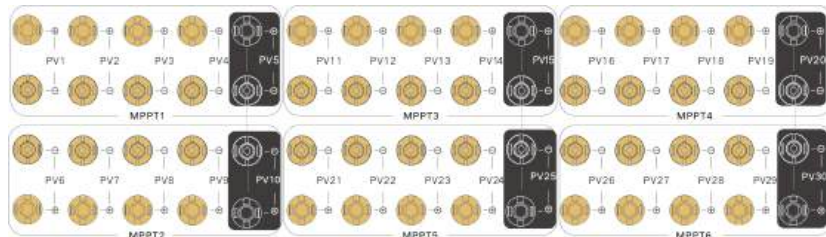


figure 5-4 Terminal Connection Schematic for 210 Module

### 5.7.2 Assembling PV Connectors

#### **⚠ DANGER**

High voltage may be present in the inverter!

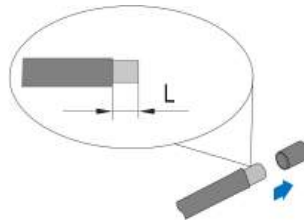
- Ensure all cables are voltage-free before performing electrical operations.
- Do not connect the AC circuit breaker before finishing electrical connection.

#### **NOTICE**

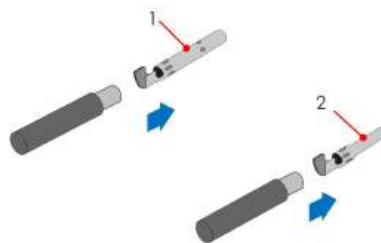
Please use the DC terminal within the scope of delivery or purchase the PV connector according to the recommended model below. Equipment damage caused by the use of unmatched terminals is not covered by the warranty.

- If the cross-sectional area of the DC cable is  $4/6\text{mm}^2$ , use the PV connector within the scope of delivery. The recommended model of the female cable connector is PV-KST4-EVO 2 / 6I-UR (Stäubli), and the recommended male cable connector is PV-KBT4-EVO 2 / 6I-UR (Stäubli).
- If the cross-sectional area of the DC cable is  $10\text{mm}^2$ , users need to prepare the PV connector by themselves or order it from SUNGROW. The recommended model of the female cable connector is PV-KBT4-EVO 2 / 10II-UR (Stäubli), and the recommended male cable connector is PV-KST4-EVO 2 / 10II-UR (Stäubli).

**step 1** Strip the insulation from each DC cable by 8 mm ~ 10 mm.



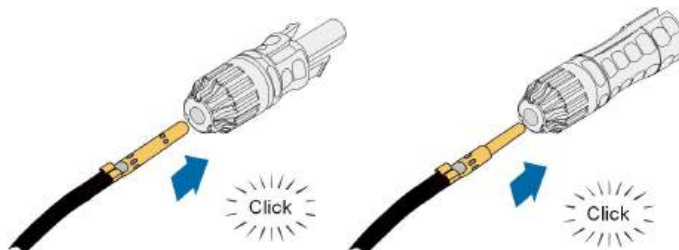
**step 2** Assemble the cable ends with the crimping pliers.



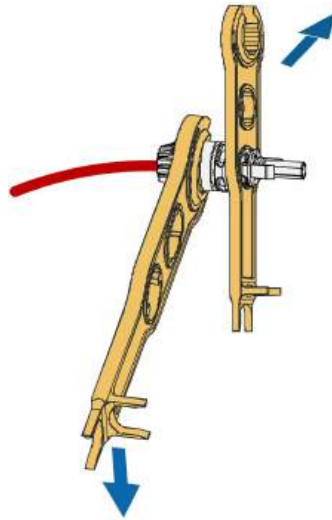
1: Positive crimp contact

2 : Negative crimp contact

**step 3** Lead the cable through the cable gland, and insert the crimp contact into the insulator until it snaps into place. Gently pull the cable backward to ensure firm connection.



**step 4** Tighten the cable gland and the insulator.



**step 5** Check for polarity correctness.

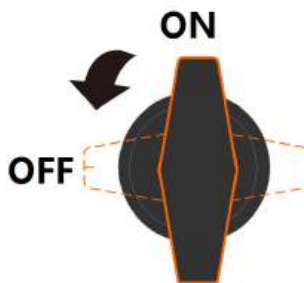
#### NOTICE

If the PV polarity is reversed, the inverter will be in a fault or alarm state and will not operate normally.

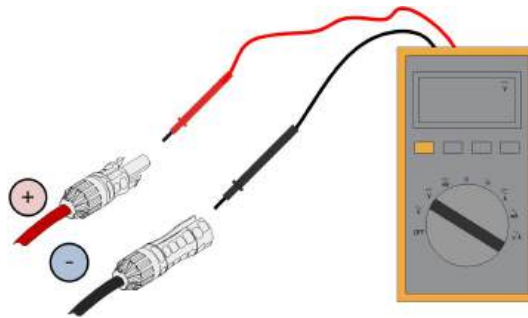
-- End

### 5.7.3 Installing PV Connector

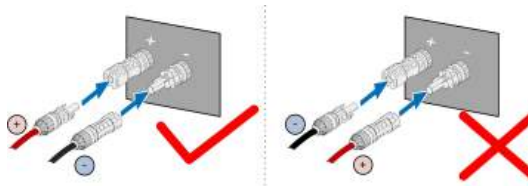
**step 1** Ensure that the DC switch is in "OFF" position. Otherwise, manually turn it to "OFF".



**step 2** Check the cable connection of the PV string for polarity correctness and ensure that the open circuit voltage in any case does not exceed the inverter input limit of



**step 3** Connect the PV connectors to corresponding terminals until there is an audible click.



**step 4** Follow the foregoing steps to connect PV connectors of other PV strings

**step 5** Seal any unused PV terminal with a terminal cap.

#### NOTICE

Turn the corresponding DC switch to "ON" after the PV string is connected to the PV terminal on the inverter.

-- End

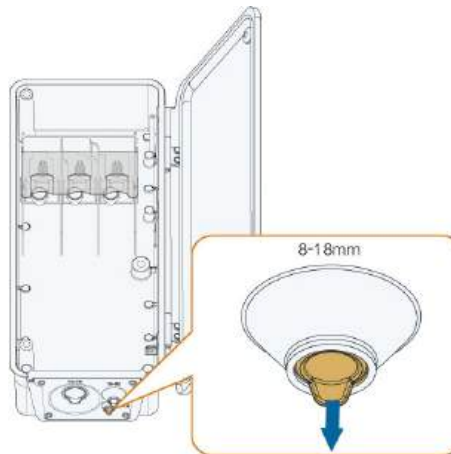
#### NOTICE

- After the PV string is connected to the input terminal on the inverter, please turn on the corresponding DC switch.
- Only when the DC switch is set to "NO", the DC Type II is able to provide effective protection against electrical surges.

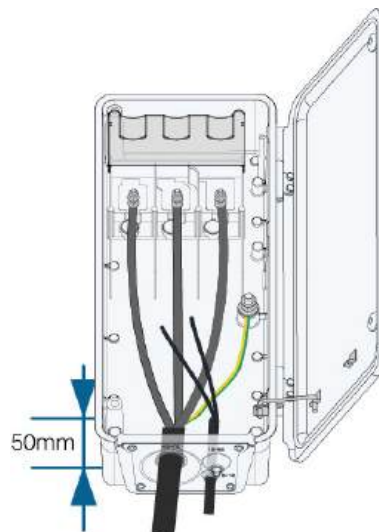
## 5.8 Wiring of Tracking System Power Cable

**step 1** Refer to step 1 to step 2 described in [5.6.3 One-wire-per-phase Wiring \(with Multi-core Cable\)](#).

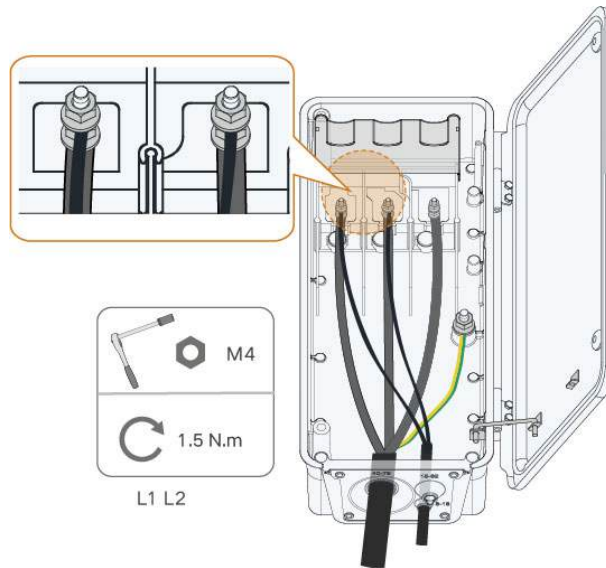
**step 2** Cut off excess sealing ring according to the outer diameter of the cable.



**step 3** Lead the cable with the protective layer removed through the sealing ring. Retain 50 mm of cable with the protective layer in the AC junction box.



**step 4** Stack the OT terminals on the OT/DT terminals of the AC cables, and fix the cables to corresponding terminals.



The tracking power cable can be installed in any two phases among L1/L2/L3.

**step 5** Close the protection cover. Close the junction box and tighten the two screws on its front cover with supplied Allen wrench.

-- End

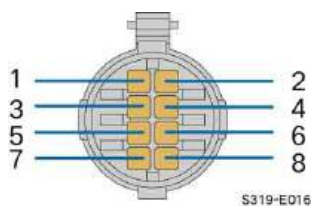


Protection devices required between the inverter and the tracking system control box: disconnecter switch ( $\geq 800$  Vac) + fuse (16A, gM).  
Length of the cable connecting the internal wiring terminal of the inverter and the fuse should be less than 2.5 m.

## 5.9 RS485 Connection(COM1)

### 5.9.1 Interface Description

The inverter communication terminal COM1 is located at the bottom of the inverter, as shown in the figure below.

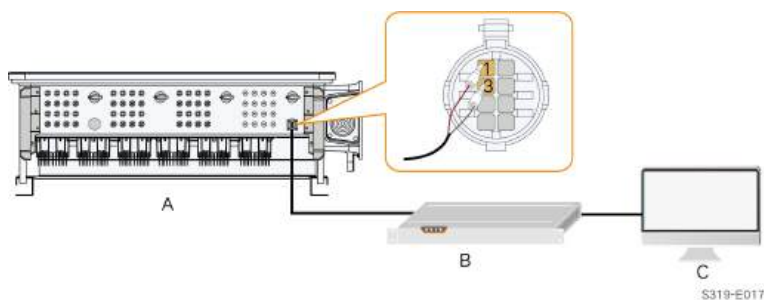
**table 5-5** COM1 Terminal Definition

Port	PIN	Definition	Description
RS485_1	1	RS485A IN, RS485 differential signal+	Used for cascading inverters or connecting to devices such as the Data Logger.
	2	RS485A IN, RS485 differential signal+	
	3	RS485B OUT, RS485 differential signal-	
	4	RS485B OUT, RS485 differential signal-	
PE	5	PE, shielding ground	—
	6	PE, shielding ground	
RS485_2	7	RS485A, RS485 differential signal+	Used for connecting to communication devices of the tracking system.
	8	RS485B, RS485 differential signal-	

## 5.9.2 RS485 Communication System

### Single-inverter Communication System

In case of a single inverter, communication cable connection requires only one RS485 cable.



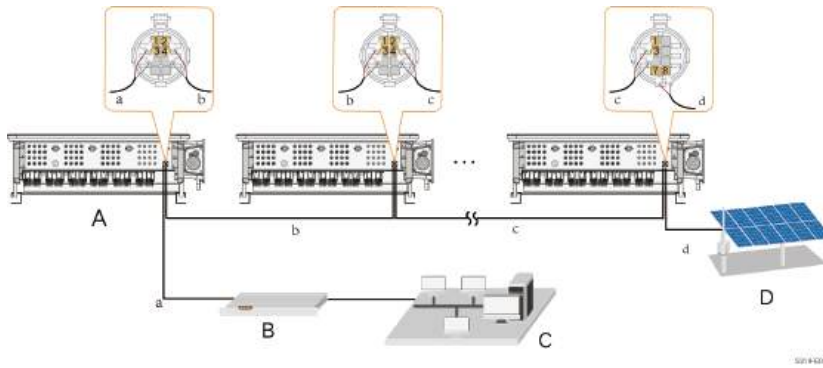
(A) Inverter

(B) Data Logger

(C) PC

### Multi-inverter Communication System

In case of multiple inverters, all the inverters can be connected via RS485 cables in the daisy chain manner. The communication cable of the tracking system can be connected to the port RS485\_2 of any inverter in the daisy chain.



(A) Inverter

(B) Data Logger

(C) PC

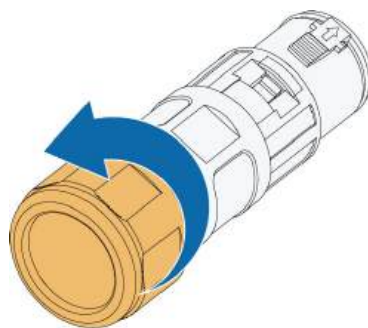
(D) Tracking system



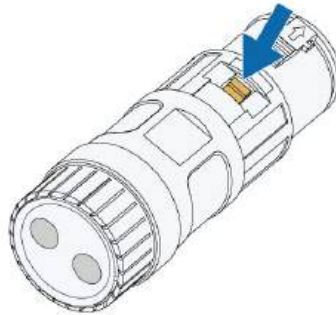
The length of the RS485 cable should be no longer than 1,000 m. If multiple inverters are connected to the data logger, the number of permissible daisy chains and the number of devices allowed to be connected should meet the requirements (refer to the user manual of the data logger).

### 5.9.3 Connection Procedure

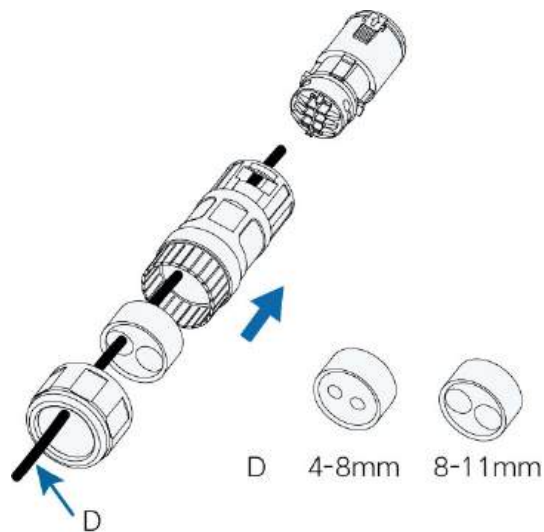
**step 1** Unscrew the swivel nut from the communication terminal and take out the seal.



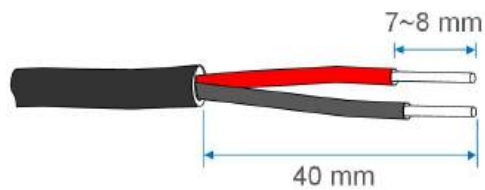
**step 2** Press the snap on both sides of the connector to separate the cable gland and the terminal block.



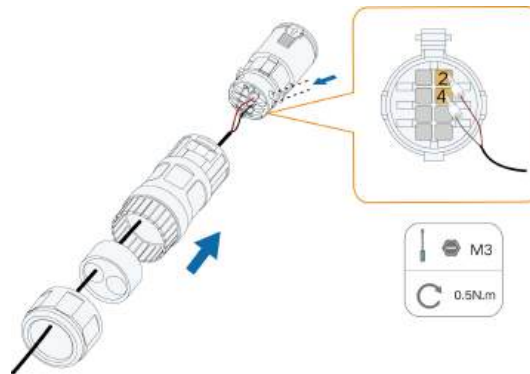
**step 3** Select a seal according to the cable outer diameter. Lead the cable through the swivel nut, seal and the cable gland.



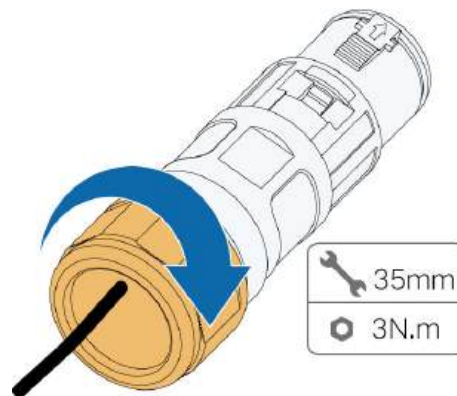
**step 4** Strip the protective layer and the insulation layer of the cable to proper length.



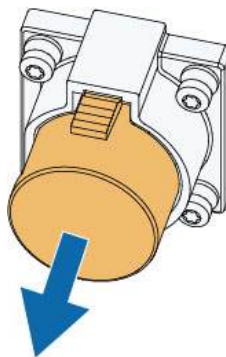
**step 5** Secure the wires to corresponding terminals.



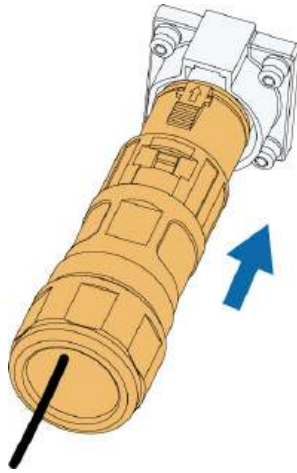
**step 6** Pull cables outwards to confirm whether they are fastened firmly, then tighten the swivel nut with appropriate torque.



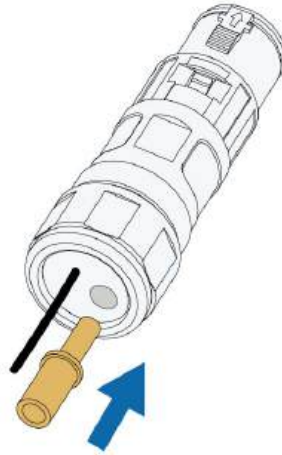
**step 7** Remove the waterproof lid from the communication terminal COM1.



**step 8** Insert the connector into the communication terminal.



**step 9** Seal the vacant cable hole with a waterproof plug.



-- End

## 5.10 PLC Communication Connection

With a PLC communication module built inside, the inverter can communicate with the Data Logger provided by SUNGROW. For specific wiring method, refer to the user manual for the data logger.



- The Data Logger is an optional device that can be ordered from SUNGROW.
- The Data Logger conducts data communication by directly using the AC output cable of the inverter and thus saves the trouble to lay and maintain the special communication cables. The RS-485 port of the Data Logger supports the transparent transmission of the MODBUS-RTU and is completely compatible with the monitoring devices and software of the original RS-485 communication method.

### 5.10.1 Application Scenarios

Device can be connected to a double-split transformer and a double-winding transformer. Wiring diagrams under these two scenarios are shown as follows. PLC1 refers to the MPLC node built in Logger4000. All cables run outside Logger 4000 in the wiring diagram, only for a clear illustration of the wiring principles.

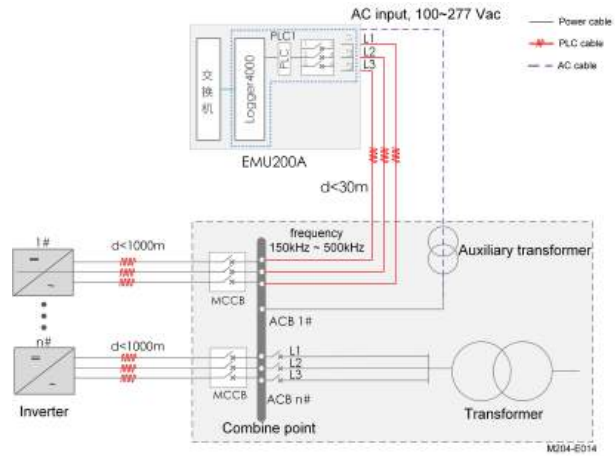


figure 5-5 PLC wiring diagram for a double-winding transformer

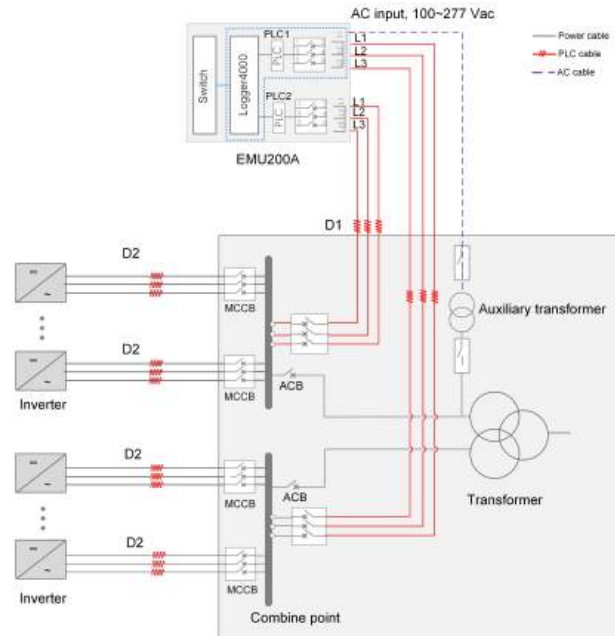





figure 5-6 PLC wiring diagram for a double-split transformer

Description of parameters in the diagrams is listed in the table below.

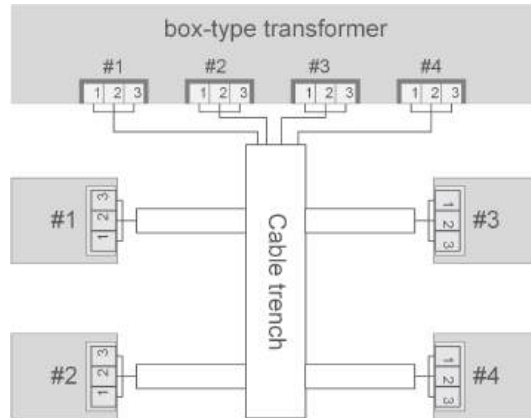
Parameter	Description	Cable Specification	Remarks
D1	Length of PLC cable from communication box to box-type transformer	<ul style="list-style-type: none"> <li>Use outdoor UV-resistant multi-core copper AC cable with a core diameter of 2.5mm<sup>2</sup>~10mm<sup>2</sup>.</li> <li>Cable isolation voltage &gt;1000V.</li> <li>Suggested length ≤10m. Shorter cable leads to better communication.</li> </ul>	
D2	Length of AC cable from box-type transformer to inverter	<ul style="list-style-type: none"> <li>Length ≤990m, if a multi-core AC cable is used.</li> <li>Length ≤790m, if a single-core AC cable is used. The cable should be fastened every 1 meter, as shown in the figure below.</li> </ul>	 
PLC module	Port input voltage	800 Vac	-
	Port supply voltage	24 Vdc	-
	Maximum number of inverters connected	80	-

### 5.10.2 AC Wiring Rules

#### Rules for AC wiring from box-type transformer to inverter

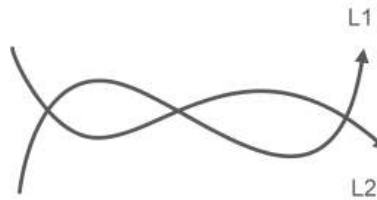
AC cables between the box-type transformer and the inverters can be laid in cable ducts, cable trenches, or pipelines. In addition, AC cable laying should be performed in compliance with requirements for AC wiring under the same box-type transformer, as well as those for AC wiring under different box-type transformers.

- Requirements for AC wiring under the same box-type transformer
  - 1 Only AC cables under the same box-type transformer can be laid in the cable trench.  
Diagram of AC wiring under the the same box-type transformer is shown below.

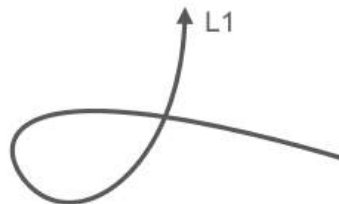


**figure 5-7** Diagram of AC wiring under the same box-type transformer

- 2 Cables can be laid in the cable trench in parallel, which however should not get entangled or knotted. There is no requirement for spacing between AC cables in the same trench.



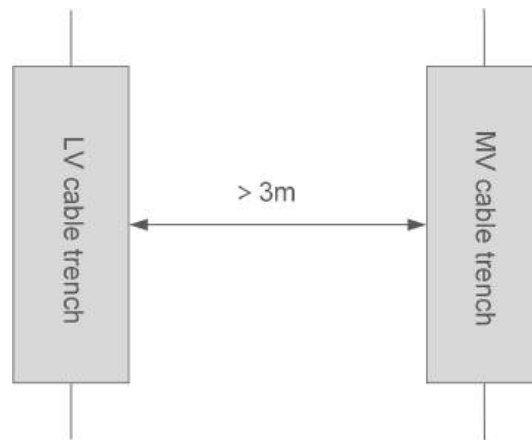
**figure 5-8** Knotted AC cable



**figure 5-9** Entangled AC cable

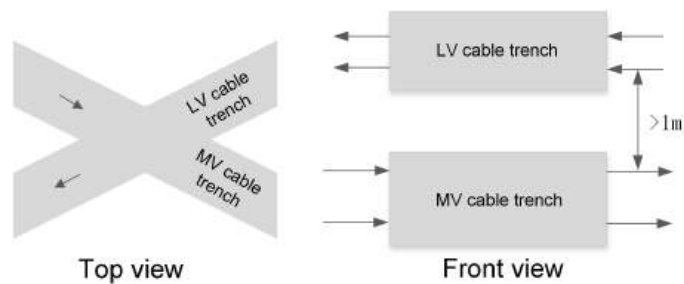
- 3 If single-core cables are adopted, AC cables of the inverters should be fastened every 1 meter with cable ties. And cables between different inverters should be laid in parallel without getting entangled or knotted.
- 4 Requirements for spacing between LV AC cable and MV AC cable of the same box-type transformer are listed as follows.

- In the case of two cables laid parallel to each other, the horizontal spacing between them should be  $>3\text{m}$ .



**figure 5-10** Horizontal spacing between AC cables (in parallel)

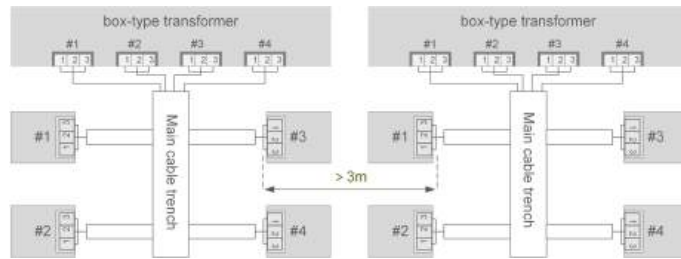
- In the case of two cables laid crosswise, the angle formed should fall in the range of  $60^\circ$ - $120^\circ$  and the vertical spacing between them should be  $>1\text{m}$ .



**figure 5-11** Vertical spacing between AC cables (crosswise)

- Requirements for AC wiring under different box-type transformers

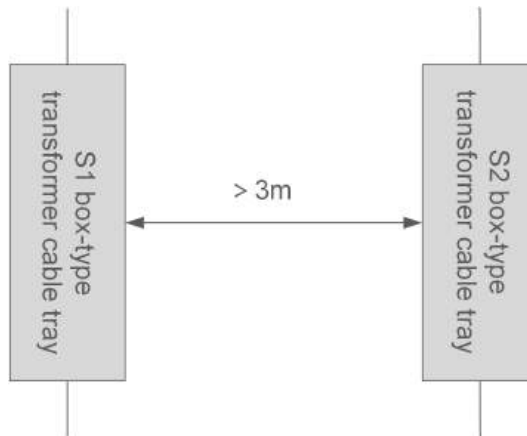
- 1 LV-side AC cables of different box-type transformers should be laid in their own cable trenches. Diagram of AC wiring under different box-type transformers is shown below.



**figure 5-12** Diagram of AC wiring under different box-type transformers

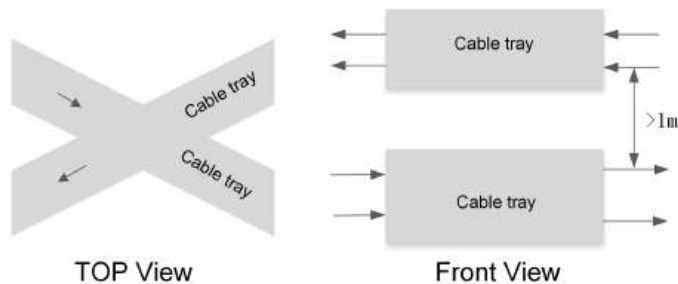
- 2 Requirements for spacing between LV-side cable trays of different box-type transformers are listed as follows.

- In the case of two cables laid parallel to each other, the horizontal spacing between them should be  $>3\text{m}$ .



**figure 5-13** Horizontal spacing between AC cables (in parallel)

- In the case of two cables laid crosswise, the angle formed should fall in the range of  $60^\circ$ - $120^\circ$  and the vertical spacing between them should be  $>1\text{m}$ .



**figure 5-14** Vertical spacing between AC cables (crosswise)

- 3 Wiring requirements of MV AC cable and LV AC cable of different box-type transformers are listed as follows.
  - In the case of two cables laid parallel to each other, the horizontal spacing between them should be  $>3\text{m}$ .
  - In the case of two cables laid crosswise, the angle formed should fall in the range of  $60^\circ$ - $120^\circ$  and the vertical spacing between them should be  $>1\text{m}$ .

### Rules for AC wiring from communication box to box-type transformer

- 1 AC cables from communication box to box-type transformer should be laid parallel to each other, without getting knotted or entangled in the cable trench.
- 2 The coupling point for connecting the AC cable to the box-type transformer busbar is recommended to be arranged in the position corresponding to the middle of the busbar. For

instance, for an 8-branch busbar, the coupling point is suggested to be set corresponding to the 4th or 5th branch busbar; while for a 9-branch busbar, it is suggested to be set corresponding to the 5th branch busbar.

- 3 Use multi-core copper AC cable with a core diameter of  $\geq 2.5\text{mm}^2$ .
- 4 Rated power-frequency voltage to ground of three-phase AC cable should be  $\geq 1000\text{V}$ . Cable length should be  $< 10\text{m}$ . Shorter cable leads to better communication.

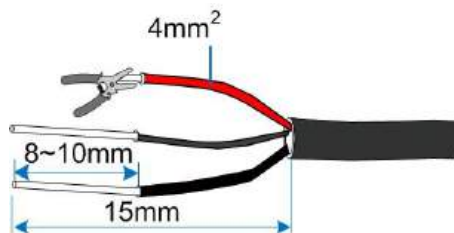
### 5.10.3 PLC Wiring

#### Pre-wiring preparation

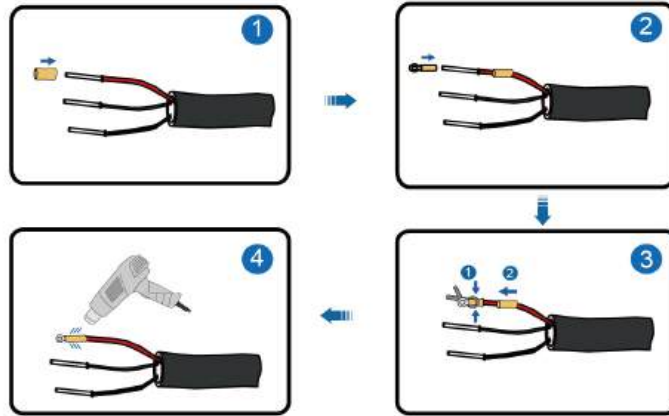
- Before performing AC wiring, please ensure that upstream AC switches and fuses inside the device are all in the open state.
- Please refer to [5.10.1 Application Scenarios](#) for PLC application scenarios and cable specifications.
- Please refer to [5.10.2 AC Wiring Rules](#) for wiring diagrams under different application scenarios.

#### Steps of wiring

- 1 Unscrew the "MPLC 800V" waterproof terminal at the bottom of the device, and lead the external AC cable through the waterproof terminal.
- 2 Remove the protective layer of the cable using a wire stripper to expose the copper core, as shown in the figure below.



- 3 Crimp the OT terminals (OT2.5-6 is recommended).



4 Connect the cable to the corresponding terminal, as shown in the figure below.

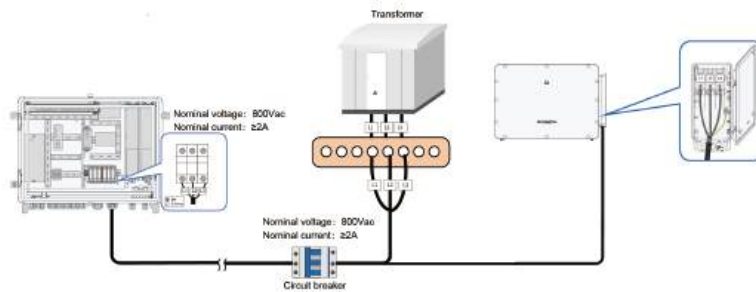


figure 5-15 Three-phase three-wire method

**i** The coupling point for connecting the PLC cable to the box-type transformer busbar is recommended to be arranged in the position corresponding to the middle of the busbar.

**i**

- For parameters of the circuit breaker on the box-type transformer side, you may refer to the parameters of EMU200A's internal circuit breaker in the above figure.
- Please pay attention to the phase sequence of cables and terminals in the wiring process.

5 Fasten the cables with screws after confirming the cables are properly prepared. Tightening torque: 5.5N·m

---

## 6 Commissioning

### 6.1 Inspection Before Commissioning

Check the following items before starting the inverter:

- All equipment has been reliably installed.
- DC switch(es) and AC circuit breaker are in the "OFF" position.
- The ground cable is properly and reliably connected.
- The AC cable is properly and reliably connected.
- The DC cable is properly and reliably connected.
- The communication cable is properly and reliably connected.
- The vacant terminals are sealed.
- No foreign items, such as tools, are left on the top of the machine or in the junction box (if there is).
- The AC circuit breaker is selected in accordance with the requirements of this manual and local standards.
- All warning signs & labels are intact and legible.

### 6.2 Commissioning Procedure

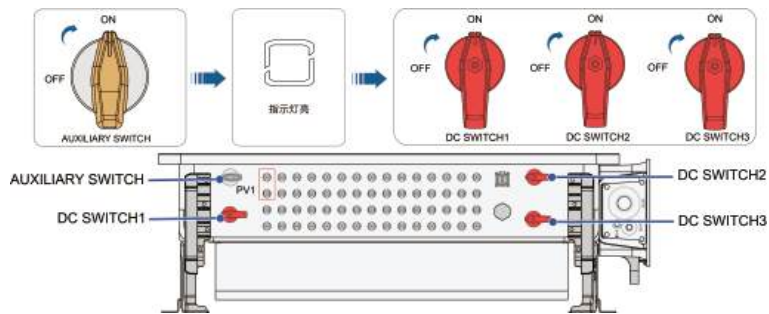
If the requirements for the above-mentioned items are all met, proceed as follows to start up the inverter for the first time.

**step 1** Make sure there is string connected to PV1.

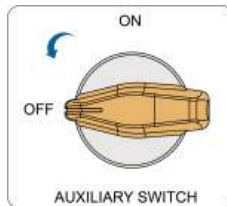
**step 2** Turn the auxiliary switch on the bottom of the inverter to "ON". Check the indicator on the inverter.

**step 3** If the indicator is on, turn the other DC switches to "ON".

- In case the DC switch turns off by itself, see [8.2.6 DC Switch Maintenance](#).
- If the inverter indicator is not on after 30 seconds, do not close the DC switches (SWITCH1, SWITCH2, SWITCH3 with red knobs), and meanwhile turn off the auxiliary switch. Check if the input cable is connected in reversed polarity, or if the input voltage meets the requirements for startup voltage. After inspections, go through again the commissioning procedure. If the indicator is still not on, turn off the auxiliary switch and contact SUNGROW for technical support.



**step 4** Turn the auxiliary switch on the inverter to “OFF”.



#### NOTICE

- Please follow the above steps strictly in order. Otherwise, the product may get damaged, and the loss caused will not be covered by the warranty.
- If the DC side is powered up while the AC side is not, the inverter indicator may turn red, and the inverter will report a “Grid Power Outage” fault (the fault information can be viewed on the iSolarCloud App. See “Records” for details). The fault will be cleared automatically once the AC circuit breaker between the inverter and the grid is closed.
- Before closing the AC circuit breaker between the inverter and the power grid, measure the AC voltage with a multimeter set to “AC voltage”, making sure it is within the allowable range. Otherwise, the inverter may be damaged.



The auxiliary switch needs to be closed only when the system is first powered on, and should be open during operation.

**step 5** Close the AC circuit breaker between the inverter and the grid.

**step 6** Install the iSolarCloud App, see [7.2 Installing App](#) for details.

**step 7** It is required to set initial protection parameters on the iSolarCloud App when the inverter is connected to the grid for the first time (see Step 4 in [7.3.2 Login Procedure](#) for details). If, with sufficient light, the grid conditions meet the grid connection requirements, the inverter will work normally.

**step 8** The home page is automatically displayed when the setting is completed. The indicator is steady blue, and the inverter is in grid-connected operation.

**⚠ WARNING**

**It is strictly forbidden to close the DC switch if the inverter is in grid-connected status. Otherwise, the inverter may be damaged due to the lack of insulation impedance detection, and the loss caused is not covered by the warranty.**

**-- End**

# 7 iSolarCloud App

## 7.1 Brief Introduction

The iSolarCloud App can establish communication connection to the inverter via the Bluetooth, thereby achieving near-end maintenance on the inverter. Users can use the App to view basic information, alarms, and events, set parameters, or download logs, etc.



Screenshots in this manual are based on the Android system V2.1.6 , and the actual interfaces may differ.

## 7.2 Installing App

### Method 1

Download and install the App through the following application stores:

- MyApp (Android, mainland China users)
- Google Play (Android, users other than mainland China ones)
- App Store (iOS)

### Method 2

Scan the following QR code to download and install the App according to the prompt information.



The App icon appears on the home screen after installation.



## 7.3 Login

### 7.3.1 Requirements

The following requirements should be met:

- The AC or DC side of the inverter is powered-on.
- The mobile phone is within 5 meters away from the inverter and there are no obstructions in between.
- The Bluetooth function of the mobile phone is enabled.



The inverter can only pair with one phone at a time through Bluetooth.

### 7.3.2 Login Procedure

**step 1** Open the App to enter the login page, tap **Local Access** at the bottom of the page to go to the next page.

**step 2** Establish the Bluetooth connection by either of the two following ways. If the LED indicator flashes blue, the connection is successfully established.

- Scan the QR code on the side of the inverter for Bluetooth connection.
- Tap "Manual connection" and select "Others" at the bottom of the page, the Bluetooth search page will automatically pop up, and select the inverter to be connected according to the SN on the nameplate on the side of the inverter body.

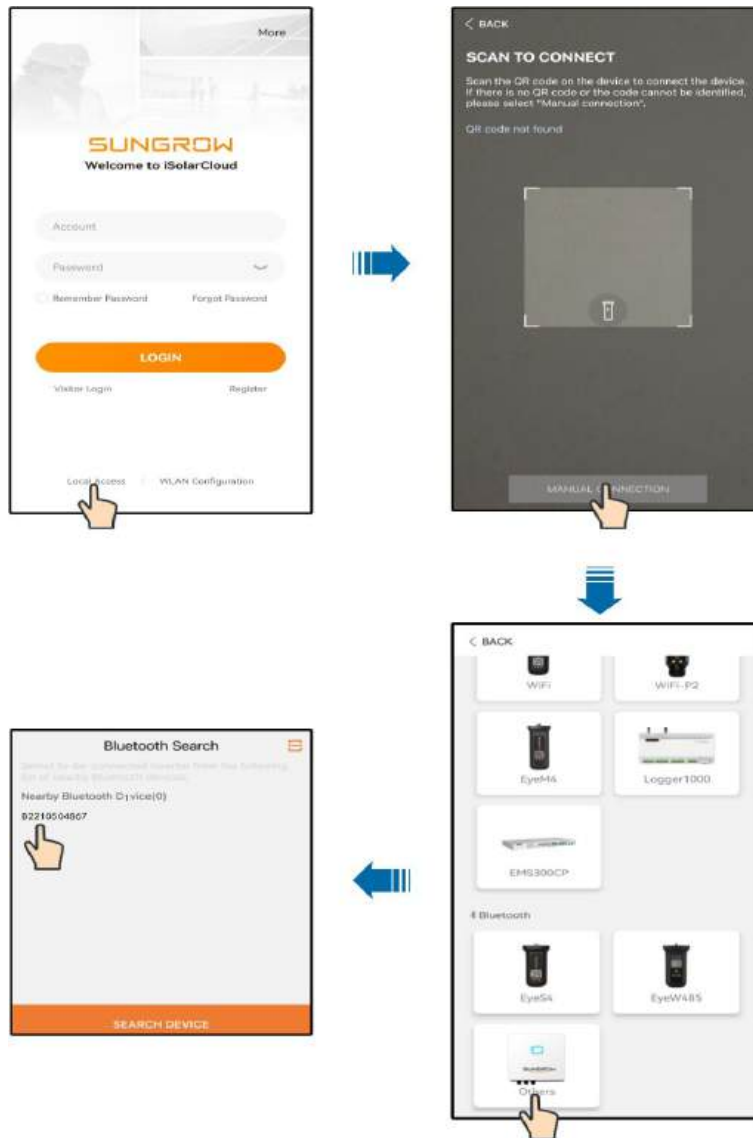


figure 7-1 Bluetooth Connection

**step 3** Enter the identity verification interface after the Bluetooth connection is established.

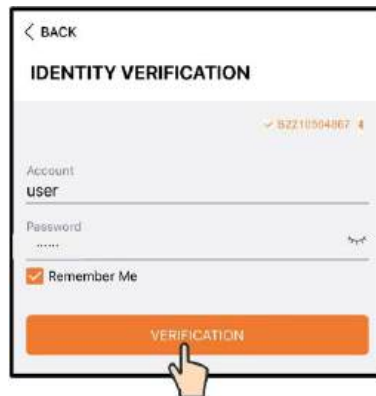


figure 7-2 Login



The Account is "user", and the initial password is "pw1111" or "111111" which should be changed for the consideration of account security.

To set inverter parameters related to grid protection and grid support, contact your distributor to obtain the advanced account and corresponding password. If the distributor is unable to provide the required information, contact SUNGROW.

**step 4** If the inverter is not initialized, you will enter the quick setting interface of initializing protection parameters.

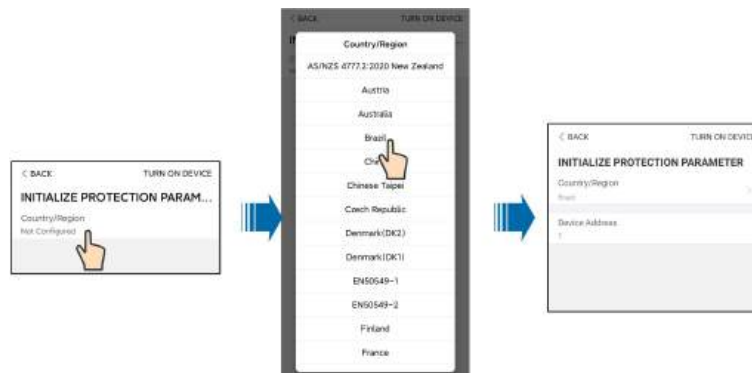


figure 7-3 Initialization Protection Parameter

#### NOTICE

The Country/Region must be set to the country where the inverter is installed. Otherwise, the inverter may report errors.

**step 5** After finishing the settings, tap **TUNR ON DEVICE** at the upper right corner and the device will be initialized. The App will send start instructions and the device will start and operate.

**step 6** If the inverter is initialized, the App automatically turns to its home page.

-- End

## 7.4 Function Overview

The App provides parameter viewing and setting functions, as shown in the following figure.

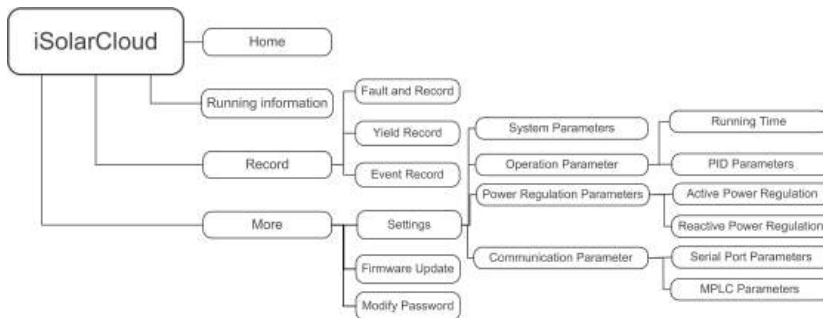


figure 7-4 App Function Tree Map

## 7.5 Home

After login, the home page is as follows:



figure 7-5 Home Page

table 7-1 Home Page Description


No.	Designation	Description
1	Date and time	System date and time of the inverter
2	Inverter state	Present operation state of the inverter. For details, refer to <a href="#">table 7-2 Description of Inverter State</a> .
3	PID function state	Present state of the PID function. For details, refer to <a href="#">table 7-3 Description of PID Function State</a>
4	Power flow chart	Display the PV power generation power, feed-in power, etc. The line with an arrow indicates energy flow between connected devices, and the arrow pointing indicates energy flow direction.
5	Real-time power	Output power of the inverter
6	Power generation	Today power yield and accumulative power yield of the inverter
7	Power curve	Curve showing change of power between 5 am and 23 pm every day (Each point on the curve represents the percentage of present inverter power to rated power)
8	Navigation bar	Including <b>Home</b> , <b>Run Information</b> , <b>Records</b> , and <b>More</b>

**table 7-2** Description of Inverter State

State	Description
Run	After being energized, inverter tracks the PV arrays' maximum power point (MPP) and converts the DC power into AC power. This is the normal operation mode.
Stop	Inverter is stopped.
Press to Shut Down	Inverter will stop operation by tapping "Stop" via app. In this way, inverter internal DSP stops. Restart the inverter via app if needed.
Standby	Inverter enters standby mode when DC side input is insufficient. In this mode inverter will wait within the standby duration.
Initial standby	The inverter is in the initial power-on standby state.
Starting up	The inverter is initializing and synchronizing with the grid.
Warn run	Warning information is detected.
Derating running	The inverter derates actively due to environmental factors such as temperature or altitude
Dispatch Running	The inverter runs according to the scheduling instructions received from the monitoring background
Shut down	If a fault occurs, inverter will automatically stop operation, the AC relay acts. The fault information will be displayed on the app. Once the fault is removed in recovery time, inverter will automatically resume running.

**table 7-3** Description of PID Function State

State	Description
PID recovery running	The inverters perform PID recovery actively.
PID abnormality	It is detected that the ISO impedance is abnormal or the PID function cannot work normally after the PID function is enabled.

If the inverter is running abnormally, the alarm or fault icon  will be displayed in the lower right corner of the inverter icon in power flow chart. The user can tap this icon to enter the alarm or fault interface to view detailed information and corrective measures.

## 7.6 Run Information

Tap **Run Information** in the navigation bar to enter the corresponding interface. Swipe upward to view details.

The run information includes the PV information, the inverter information, and input and output information.

**table 7-4** Run Information

Classification	Parameter Name	Description
PV Information	String n Voltage	The input voltage of String n
	String n Current	The input current of String n
Inverter Information	Total On-grid Running Time	/
	Daily On-grid Running Time	/
	Negative Voltage to Ground	Inverter DC side negative to ground voltage value
	Bus Voltage	Voltage between the positive and negative poles of the DC side of the inverter
	Internal Air Temperature	/
	Array Insulation Resistance	Insulation resistance value of the input side to the protection ground
	Country/Region	/
	Power Limitation Mode	/
Input	Reactive Power Mode	/
	Total DC Power	DC side total input power
	MPPT x Voltage	The input voltage of MPPT x
Output	MPPT x Current	The input current of MPPT x
	Daily Yield	/
	Monthly Yield	/
	Annual Yield	/
	Total Active Power	Current active power value of the inverter
	Total Reactive Power	Current reactive power value of the inverter
	Total Apparent Power	Current apparent power value of the inverter
	Total Power Factor	Power factor of the AC side of the inverter
	Grid Frequency	Frequency of the AC side of the inverter
	A-B Line Voltage	Line voltage
	B-C Line Voltage	
C-A Line Voltage		
Phase A Current	Phase current	
Phase B Current		

Classification	Parameter Name	Description
	Phase C Current	

## 7.7 Records

Tap **Records** on the navigation bar to enter the interface showing event records, as shown in the following figure.



figure 7-6 Records


### Fault Alarm Record

Tap **Fault Alarm Record** to enter the interface, as shown in the following figure.



figure 7-7 Fault Alarm Record



Tap  to select a time segment and view corresponding records. The inverter can record up to 400 latest entries.

Select one of the records in the list and tap the record to view the detailed fault information as shown in following figure.



**figure 7-8** Detailed Fault Alarm Information

### Yield Record

Tap **Yield Record** to enter the interface showing daily power generation as shown in the following figure.



**figure 7-9** Power Curve

The App displays power generation records in a variety of forms, including daily power generation histogram,, monthly power generation histogram, annual power generation histogram and total power generation histogram.

**table 7-5** Yield Record Explanation

Parameter	Description
Power curve	Show the power output from 5 am to 11 pm in a single day. Each point on the curve represents the percentage of present inverter power to rated power.

Parameter	Description
Daily yield histogram	Shows the power output every day in the present month.
Monthly yield histogram	Shows the power output every month in a year.
Annual yield histogram	Shows the power output every year.


Tap the time bar on the top of the interface to select a time segment and view the corresponding power curve.

Swipe left to check the power yields histogram.

## Event Record

Tap **Event Record** to view event record list.



Tap  to select a time segment and view corresponding records. The inverter can record up to 400 latest entries.

## 7.8 More

Tap **More** on the navigation bar to enter the corresponding interface, as shown in the following figure.

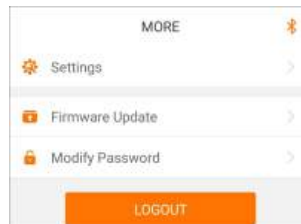


figure 7-10 More

### 7.8.1 System Parameters

Tap **Settings > System Parameters** to enter the corresponding interface, as shown in the following figure.



**figure 7-11** System Parameters

\* The image shown here is for reference only.

### Boot/Shutdown

Tap **Boot/Shutdown** to send the boot/shutdown instruction to the inverter.

### Date Setting/Time Setting

The correct system time is very important. Wrong system time will directly affect the data logging and power generation value. The clock is in 24-hour format.

### Software Version

Version information of the current firmware.

## 7.8.2 Operation Parameters

### Running Time

Tap **Settings > Operation Parameters > Running Time** to enter the corresponding interface.



**figure 7-12** Running Time

### Fault Recovery

Tap **Settings > Operation Parameters > Fault Recovery** to go to "Fault Recovery".



**figure 7-13** Fault Recovery

**table 7-6** Fault Recovery Settings

Parameter	Description
Auto Fault Recovery	Used to decide whether the inverter can start up without manual intervention after a fault event. Enabled: The inverter can resume normal operation without manual intervention. Disabled: The inverter cannot resume normal operation automatically without manual intervention.
Trip all DC switches	Trip all DC switches via one touch.
Clear all tripping alarms	Clear all DC switch tripping alarms manually.

### Regular Parameters

Tap **Settings > Operation Parameters > Regular Parameters** to go to “Regular Parameters”.



**figure 7-14** Regular Parameters

## 7.8.3 Power Regulation Parameters

### Active Power Regulation

Tap **Settings > Power Regulation Parameters > Active Power Regulation** to enter the interface, as shown in the following figure.

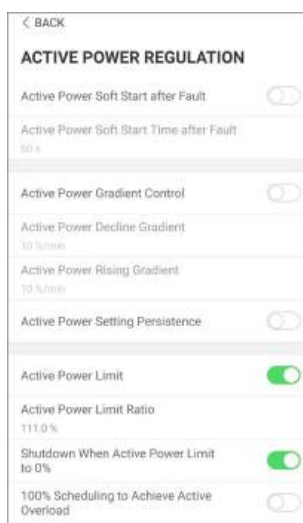


figure 7-15 Active Power Regulation

table 7-7 Active Power Regulation

Parameter	Definition/Setting Description	Range
<b>Active Power Soft Start after Fault</b>	The switch for enabling/disabling the soft start function after a fault occurs.	Enable/Disable
<b>Active Power Soft Start Time after Fault</b>	Time that the soft start takes to raise the power from 0 to 100% rated power.	1s ~ 1200s
<b>Active Power Gradient Control</b>	Select whether to allow setting the active power rate.	Enable/Disable
<b>Active Power Decline Gradient</b>	The decline rate of inverter active power per minute.	1%/min ~ 6000%/min
<b>Active Power Rising Gradient</b>	The rise rate of inverter active power per minute.	1%/min ~ 6000%/min
<b>Active Power Setting Persistence</b>	Select whether to retain the output limited power settings	Enable/Disable
<b>Active Power Limit</b>	The switch for limiting output power.	Enable/Disable
<b>Active Power Limit Ratio</b>	The ratio of limiting output power to rated power in percentage.	0% ~ 110%
<b>Shutdown When Active Power Limit to 0%</b>	Select whether to shut down the inverter when the limited power reaches 0.	Enable/Disable

Parameter	Definition/Setting Description	Range
<b>100% Scheduling to achieve active overload</b>	Switch used to ensure that the inverter operates at the maximum active power when the active power limit ratio is set over 100%.	Enable/Disable
Zero Power Output Power Compensation Value	0.4kW by default	-10kW ~ 10kW

### Reactive Power Regulation

Tap **Settings > Power Regulation Parameters > Reactive Power Regulation** to enter the screen, as shown in the following figure.



**figure 7-16** Reactive Power Regulation

**table 7-8** Reactive Power Regulation

Parameter	Definition/Setting Description	Range
Reactive power generation at night	Switch for enabling/disabling night SVG function.	Enable/Disable
Reactive power ratio at night	Reactive power ratio set for the night SVG function.	-100%~0%/0%~100%
Reactive power setting persistence	Switch for enabling/disabling the power-off function during reactive power.	Enable/Disable
Reactive closed-loop control	Switch for enabling/disabling the closed-loop control during reactive power.	Enable/Disable

Parameter	Definition/Setting Description	Range
Reactive power regulation mode	Switch for selecting reactive power regulation mode	Off/PF/Qt/Q(P)/Q(U)

The inverter provides the reactive power regulation function. Enable this function under **Reactive Power Regulation Mode** and select the appropriate mode.

**table 7-9** Reactive Power Regulation:

Mode	Descriptions
Off	The PF is fixed at +1.000.
PF	The reactive power can be regulated by the parameter PF (Power Factor).
Qt	The reactive power can be regulated by the parameter Q-Var limits (in %).
Q(P)	The PF changes with the output power of the inverter.
Q(U)	The reactive power changes with the grid voltage.

#### “Off” Mode

The reactive power regulation function is disabled. The PF is limited to +1.000.

#### “PF” Mode

The power factor is fixed and reactive power setpoint is calculated according to the current power. The range of PF is (-1.0 to -0.8) and (+0.8 to +1.0).

Leading: the inverter is sourcing reactive power to the grid.

Lagging: the inverter is injecting reactive power into the grid.

#### “Qt” Mode

In the Qt mode, system rated reactive power is fixed, and the system injects reactive power according to the delivered reactive power ratio. The **Reactive Power Ratio** is set through the App.

The setting range of the reactive power ratio is 0~100% for inductive reactive power regulation or 0~-100% for capacitive reactive power regulation.

#### “Q(P)” Mode

The PF of the inverter output varies in response to the output power of the inverter.

**table 7-10** “Q(P)” Mode Parameter Descriptions:

Parameter	Definition/Setting Description	Range
<b>Reactive response</b>	Switch for enabling/disabling reactive response	Enable/Disable
<b>Reactive response Time</b>	Completion time of reactive response	0.1s ~ 600.0s
<b>Q(P) Curve</b>	Select corresponding curve according to local regulations	A, B, C*
<b>QP_P1</b>	Output power at P1 on the Q(P) mode curve (in percentage)	0 ~ 100%

Parameter	Definition/Setting Description	Range
QP_P2	Output power at P2 on the Q(P) mode curve (in percentage)	20% ~ 100%
QP_P3	Output power at P3 on the Q(P) mode curve (in percentage)	20% ~ 100%
QP_K1	Power factor at P1 on the Q(P) mode curve	Curve A/C: 0.8 ~ 1 Curve B: [-0.600~0-.600]*Active Overload Rate/1000
QP_K2	Power factor at P2 on the Q(P) mode curve	
QP_K3	Power factor at P3 on the the Q(P) mode curve	
QP_EnterVoltage	Voltage percentage for Q(P) function activation	100% ~ 110%
QP_ExitVoltage	Voltage percentage for Q(P) function deactivation	90% ~ 100%
QP_ExitPower	Power percentage for Q(P) function deactivation	1% ~ 100%
QP_EnableMode	Unconditional activation/deactivation of Q(P) function	Yes / No

\* Curve C is reserved and consistent with Curve A currently.

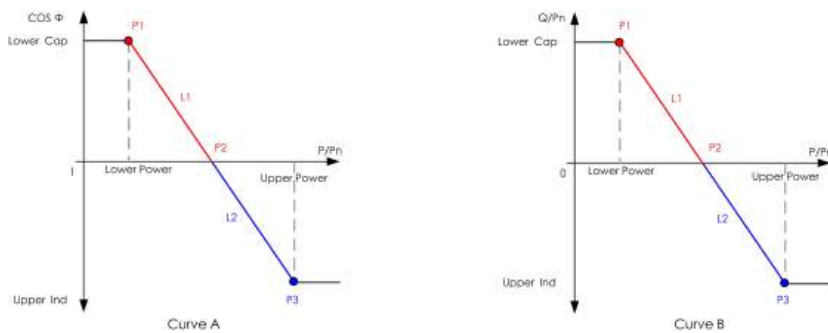


figure 7-17 Q(P) Curve

“Q(U)” Mode

table 7-11 “Q(U)” Mode Parameter Descriptions:

Parameter	Definition/Setting Description	Range
Reactive Response	Switch for enabling/disabling reactive response	Enable/Disable
Reactive Response Time	Completion time of reactive response	0.1s~600.0s
Q(U) Curve	Select corresponding curve according to local regulations	A, B, C*

Parameter	Definition/Setting Description	Range
<b>Hysteresis Ratio</b>	Voltage hysteresis ratio on the Q(U) mode curve	0 ~ 5%
<b>QU_V1</b>	Grid voltage limit at P1 on the Q(U) mode curve	80% ~ 100%
<b>QU_Q1</b>	Value of Q/Sn at P1 on the Q(U) mode curve	[-60.0%-0]* Overload Rate/ 1000
<b>QU_V2</b>	Grid voltage limit at P2 on the Q(U) mode curve	80% ~ 100%
<b>QU_Q2</b>	Value of Q/Sn at P2 on the Q(U) mode curve	[-60.0%-60.0%]* Overload Rate/1000
<b>QU_V3</b>	Grid voltage limit at P3 on the Q(U) mode curve	100% ~ 120%
<b>QU_Q3</b>	Value of Q/Sn at P3 on the Q(U) mode curve	[-60.0%-60.0%]* Overload Rate/1000
<b>QU_V4</b>	Grid voltage limit at P4 on the Q(U) mode curve	100% ~ 120%
<b>QU_Q4</b>	Value of Q/Sn at P4 on the Q(U) mode curve	[0-60.0%]* Overload Rate/ 1000
<b>QU_EnterPower</b>	Active power for Q(U) function activation	20% ~ 100%
<b>QU_ExitPower</b>	Active power for Q(U) function deactivation	1% ~ 20%
<b>QU_EnableMode</b>	Unconditional activation/deactivation of Q(U) function	Yes / No / Yes, Limited by PF
<b>QU_Limited PF Value</b>	PF value for Q(U) function activation	0 ~ 1.00

\* Curve C is reserved and consistent with Curve A currently.

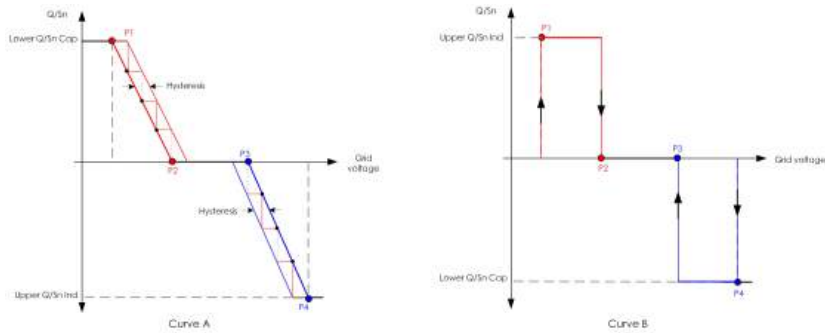


figure 7-18 Q(U) Curve

### 7.8.4 Communication Parameters

#### Serial Port Parameters

Tap **Settings > Communication Parameters > Serial Port Parameters** to enter the corresponding interface, as shown in the following figure.



figure 7-19 Serial Port Parameters

table 7-12 Serial Port Parameters

Parameter	Range
Device Address	1 ~ 246
Baud rate	9600bps , 19200bps , 38400bps , 57600bps , 115200bps

#### MPLC Parameters

Tap **Settings > Communication Parameters > MPLC Parameters** to enter the corresponding interface, as shown in the following figure.

MPLC PARAMETERS	
Band Num	Band1
Array ID	1
Winding ID	1


figure 7-20 MPLC Parameters

table 7-13 MPLC Parameters


Parameter	Range
Band Num	Band1, Band2,Band1 by default
Array ID	1 ~ 255; 2 by default
Winding ID	1 ~ 10; 1 by default

### 7.8.5 Firmware Update

To avoid download failure due to poor on-site network signal, it is recommended to download the firmware package to the mobile device in advance.

- step 1** Enable the "Mobile data" of the mobile device.
- step 2** Open the App, enter the account and password on the login interface. Tap **Login** to enter the home interface.
- step 3** Tap **More > Firmware Download** to enter corresponding interface on which you can view the device list.
- step 4** Select the device model before downloading the firmware. Tap the device name in the device list to enter the firmware upgrade package detail interface, and tap  behind the firmware upgrade package to download it.



- step 5** Return to the **Firmware Download** interface, tap  in the upper right corner of the interface to view the downloaded firmware upgrade package.
- step 6** Login the App via local access mode. Refer to [7.3 Login](#).
- step 7** Tap **More** on the App home interface and then tap **Firmware Update**.

**step 8** Tap the upgrade package file, a prompt box will pop up asking whether to upgrade the firmware with the file, tap **CONFIRM** to perform the firmware upgrade.



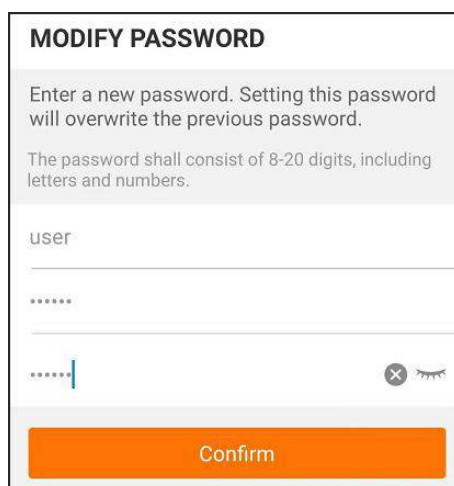
**step 9** Wait for the file to be uploaded. When the upgrade is finished, a message is displayed indicating that the upgrade is completed. Tap **Complete** to end the upgrade.



-- End

## 7.8.6 Password Changing

Tap **Modify Password** to enter the modify password interface, as shown in the following figure.



**figure 7-21** Modify Password

The password shall consist of 8–20 digits, including letters and numbers.

## 8 Troubleshooting and Maintenance

### 8.1 Troubleshooting

Once the inverter fails, the fault information is displayed on the App interface. If the inverter is equipped with an LCD screen, the fault information can be viewed on it.

The fault codes and troubleshooting methods of all PV inverters are detailed in the table below, and only some of the faults may occur to the model you purchased. When a fault occurs, you can check the fault information according to the fault code on the mobile app.

Fault Code	Fault Name	Corrective Measures
2, 3, 14, 15	Grid Overvoltage	<p>Generally, the inverter will be reconnected to the grid after the grid returns to normal. If the fault occurs repeatedly:</p> <ol style="list-style-type: none"><li>1. Measure the actual grid voltage, and contact the local electric power company for solutions if the grid voltage is higher than the set value.</li><li>2. Check whether the protection parameters are appropriately set via the App or the LCD. Modify the overvoltage protection values with the consent of the local electric power operator.</li><li>3. Contact Sungrow Customer Service if the preceding causes are ruled out and the fault persists.</li></ol>
4, 5	Grid Undervoltage	<p>Generally, the inverter will be reconnected to the grid after the grid returns to normal. If the fault occurs repeatedly:</p> <ol style="list-style-type: none"><li>1. Measure the actual grid voltage, and contact the local electric power company for solutions if the grid voltage is lower than the set value.</li><li>2. Check whether the protection parameters are appropriately set via the App or the LCD.</li><li>3. Check whether the AC cable is firmly in place.</li><li>4. Contact Sungrow Customer Service if the preceding causes are ruled out and the fault persists.</li></ol>

Fault Code	Fault Name	Corrective Measures
8	Grid Overfrequency	<p>Generally, the inverter will be reconnected to the grid after the grid returns to normal. If the fault occurs repeatedly:</p> <ol style="list-style-type: none"> <li>1. Measure the actual grid frequency, and contact the local electric power company for solutions if the grid frequency is beyond the set range.</li> <li>2. Check whether the protection parameters are appropriately set via the App or the LCD.</li> <li>3. Contact Sungrow Customer Service if the preceding causes are ruled out and the fault persists.</li> </ol>
9	Grid Underfrequency	<p>Generally, the inverter will be reconnected to the grid after the grid returns to normal. If the fault occurs repeatedly:</p> <ol style="list-style-type: none"> <li>1. Check whether the grid supplies power reliably.</li> <li>2. Check whether the AC cable is firmly in place.</li> <li>3. Check whether the AC cable is connected to the correct terminal (whether the live wire and the N wire are correctly in place).</li> <li>4. Check whether the AC circuit breaker is connected.</li> <li>5. Contact Sungrow Customer Service if the preceding causes are ruled out and the fault persists.</li> </ol>
10	Grid Power Outage	<p>Generally, the inverter will be reconnected to the grid after the grid returns to normal. If the fault occurs repeatedly:</p> <ol style="list-style-type: none"> <li>1. Check whether the grid supplies power reliably.</li> <li>2. Check whether the AC cable is firmly in place.</li> <li>3. Check whether the AC cable is connected to the correct terminal (whether the live wire and the N wire are correctly in place).</li> <li>4. Check whether the AC circuit breaker is connected.</li> <li>5. Contact Sungrow Customer Service if the preceding causes are ruled out and the fault persists.</li> </ol>
12	Excess Current Leakage	<ol style="list-style-type: none"> <li>1. The fault can be caused by poor sunlight or damp environment, and generally the inverter will be reconnected to the grid after the environment is improved.</li> <li>2. If the environment is normal, check whether the AC and DC cables are well insulated.</li> <li>3. Contact Sungrow Customer Service if the preceding causes are ruled out and the fault persists.</li> </ol>
13	Grid Abnormal	<p>Generally, the inverter will be reconnected to the grid after the grid returns to normal. If the fault occurs repeatedly:</p> <ol style="list-style-type: none"> <li>1. Measure the actual grid, and contact the local electric power company for solutions if the grid parameter exceeds the set range.</li> <li>2. Contact Sungrow Customer Service if the preceding causes are ruled out and the fault persists.</li> </ol>

Fault Code	Fault Name	Corrective Measures
17	Grid Voltage Imbalance	<p>Generally, the inverter will be reconnected to the grid after the grid returns to normal. If the fault occurs repeatedly:</p> <ol style="list-style-type: none"> <li>1. Measure the actual grid voltage. If grid phase voltages differ greatly, contact the electric power company for solutions.</li> <li>2. If the voltage difference between phases is within the permissible range of the local power company, modify the grid voltage imbalance parameter through the App or the LCD.</li> <li>3. Contact Sungrow Customer Service if the preceding causes are ruled out and the fault persists.</li> </ol>
28, 29, 208, 212, 448-479	PV Reserve Connection Fault	<ol style="list-style-type: none"> <li>1. Check whether the corresponding string is of reverse polarity. If so, disconnect the DC switch and adjust the polarity when the string current drops below 0.5 A.</li> <li>2. Contact Sungrow Customer Service if the preceding causes are ruled out and the fault persists.</li> </ol> <p>*The code 28 to code 29 are corresponding to PV1 to PV2 respectively. *The code 448 to code 479 are corresponding to string 1 to string 32 respectively.</p>
532-547, 564-579	PV Reverse Connection Alarm	<ol style="list-style-type: none"> <li>1. Check whether the corresponding string is of reverse polarity. If so, disconnect the DC switch and adjust the polarity when the string current drops below 0.5 A.</li> <li>2. Contact Sungrow Customer Service if the preceding causes are ruled out and the alarm persists.</li> </ol> <p>*The code 532 to code 547 are corresponding to string 1 to string 16 respectively. *The code 564 to code 579 are corresponding to string 17 to string 32 respectively.</p>

Fault Code	Fault Name	Corrective Measures
548-563, 580-595	PV Abnormal Alarm	<p>Check whether the voltage and current of the inverter is abnormal to determine the cause of the alarm.</p> <ol style="list-style-type: none"> <li>1. Check whether the corresponding module is sheltered. If so, remove the shelter and ensure module cleanness.</li> <li>2. Check whether the battery board wiring is loose, if so, make it reliably connected.</li> <li>3. Check if the DC fuse(if there is fuse between PV string and inverter DC input) is damaged. If so, replace the fuse.</li> <li>4. Contact Sungrow Customer Service if the preceding causes are ruled out and the alarm persists.</li> </ol> <p>*The code 548 to code 563 are corresponding to string 1 to string 16 respectively. *The code 580 to code 595 are corresponding to string 17 to string 32 respectively.</p>
37	Excessively High Ambient Temperature	<p>Generally, the inverter will resume operation when the internal or module temperature returns to normal. If the fault persists:</p> <ol style="list-style-type: none"> <li>1. Check whether the ambient temperature of the inverter is too high;</li> <li>2. Check whether the inverter is in a well-ventilated place;</li> <li>3. Check whether the inverter is exposed to direct sunlight. Shield it if so;</li> <li>4. Check whether the fan is running properly. Replace the fan if not;</li> <li>5. Contact Sungrow Power Customer Service if the fault is due to other causes and the fault persists.</li> </ol>
43	Excessively Low Ambient Temperature	<p>Stop and disconnect the inverter. Restart the inverter when the ambient temperature rises within the operation temperature range.</p>

Fault Code	Fault Name	Corrective Measures
39	Low System Insulation Resistance	<p>Wait for the inverter to return to normal. If the fault occurs repeatedly:</p> <ol style="list-style-type: none"> <li>1. Check whether the ISO resistance protection value is excessively high via the app or the LCD, and ensure that it complies with the local regulations.</li> <li>2. Check the resistance to ground of the string and DC cable. Take corrective measures in case of short circuit or damaged insulation layer.</li> <li>3. If the cable is normal and the fault occurs on rainy days, check it again when the weather turns fine.</li> <li>4. If there are batteries, check whether battery cables are damaged and whether terminals are loose or in poor contact. If so, replace the damaged cable and secure terminals to ensure a reliable connection.</li> <li>5. Contact Sungrow Customer Service if the preceding causes are ruled out and the fault persists.</li> </ol>
106	Grounding Cable Fault	<ol style="list-style-type: none"> <li>1. Check whether the AC cable is correctly connected.</li> <li>2. Check whether the insulation between the ground cable and the live wire is normal.</li> <li>3. Contact Sungrow Customer Service if the preceding causes are ruled out and the fault persists.</li> </ol>
88	Electric Arc Fault	<ol style="list-style-type: none"> <li>1. Disconnect the DC power supply, and check whether any DC cable is damaged, the connection terminal or fuse is loose or there is a weak contact. If so, replace the damaged cable, fasten the terminal or fuse, and replace the burnt component.</li> <li>2. After performing step 1, reconnect the DC power supply, and clear the electric arc fault via the App or the LCD, after that the inverter will return to normal.</li> <li>3. Contact Sungrow Customer Service if the fault persists.</li> </ol>

Fault Code	Fault Name	Corrective Measures
84	Reverse Connection Alarm of the Meter/CT	<ol style="list-style-type: none"> <li>1. Check if the meter is wrongly connected.</li> <li>2. Check if the input and output wiring of the meter is reversed.</li> <li>3. If the existing system is enabled, please check if the rated power setting of the existing inverter is correct.</li> </ol>
514	Meter Communication Abnormal Alarm	<ol style="list-style-type: none"> <li>1. Check whether the communication cable and the terminals are abnormal. If so, correct them to ensure reliable connection.</li> <li>2. Reconnect the communication cable of the meter.</li> <li>3. Contact Sungrow Customer Service if the preceding causes are ruled out and the alarm persists.</li> </ol>
323	Grid Confrontation	<ol style="list-style-type: none"> <li>1. Check whether the output port is connected to actual grid. Disconnect it from the grid if so.</li> <li>2. Contact Sungrow Customer Service if the preceding causes are ruled out and the fault persists.</li> </ol>
75	Inverter Parallel Communication Alarm	<ol style="list-style-type: none"> <li>1. Check whether the communication cable and the terminals are abnormal. If so, correct them to ensure reliable connection.</li> <li>2. Reconnect the communication cable of the meter.</li> <li>3. Contact Sungrow Customer Service if the preceding causes are ruled out and the alarm persists.</li> </ol>
7, 11, 16, 19–25, 30–34, 36, 38, 40–42, 44–50, 52–58, 60–69, 85, 87, 92, 93, 100–105, 107– 114, 116–124, 200–211, 248– 255, 300–322, 324–328, 401– 412, 600–603, 605, 608, 612, 616, 620, 622– 624, 800, 802, 804, 807, 1096– 1122	System Fault	<ol style="list-style-type: none"> <li>1. Wait for the inverter to return to normal.</li> <li>2. Disconnect the AC and DC switches, and disconnect the battery side switches if there are batteries. Close the AC and DC switches in turn 15 minutes later and restart the system.</li> <li>3. Contact Sungrow Customer Service if the preceding causes are ruled out and the fault persists.</li> </ol>

Fault Code	Fault Name	Corrective Measures
59, 70–74, 76–83, 89, 216–218, 220–233, 432–434, 500–513, 515–518, 635–638, 900, 901, 910, 911, 996	System Alarm	<ol style="list-style-type: none"> <li>1. The inverter can continue running.</li> <li>2. Check whether the related wiring and terminal are abnormal, check whether there are any foreign materials or other environmental abnormalities, and take corresponding corrective measures when necessary.</li> <li>3. If the fault persists, please contact Sungrow Power Customer Service.</li> </ol>
264-283	MPPT Reverse Connection	<ol style="list-style-type: none"> <li>1. Check whether the corresponding string is of reverse polarity. If so, disconnect the DC switch and adjust the polarity when the string current drops below 0.5 A.</li> <li>2. Contact Sungrow Customer Service if the preceding causes are ruled out and the fault persists.</li> </ol> <p>*The code 264 to code 279 are corresponding to string 1 to string 20 respectively.</p>
332-363	Boost Capacitor Overvoltage Alarm	<ol style="list-style-type: none"> <li>1. The inverter can continue running.</li> <li>2. Check whether the related wiring and terminals are abnormal, check whether there are any foreign materials or other environmental abnormalities, and take corresponding corrective measures when necessary.</li> </ol> <p>If the fault persists, please contact Sungrow Power Customer Service.</p>
364-395	Boost Capacitor Overvoltage Fault	<ol style="list-style-type: none"> <li>1. Disconnect the AC and DC switches, and disconnect the battery side switches if there are batteries. Close the AC and DC switches in turn 15 minutes later and restart the system.</li> <li>2. If the fault persists, please contact Sungrow Power Customer Service.</li> </ol>

Fault Code	Fault Name	Corrective Measures
1548-1579	String Current Re-flux	<ol style="list-style-type: none"> <li>1. Check whether the number of PV modules of the corresponding string is less than other strings. If so, disconnect the DC switch and adjust the PV module configuration when the string current drops below 0.5 A.</li> <li>2. Check whether the PV module is shaded;</li> <li>3. Disconnect the DC switch to check whether the open circuit voltage is normal when the string current drops below 0.5 A. If so, check the wiring and configuration of the PV module,</li> <li>4. Check whether the orientation of the PV module is abnormal.</li> </ol>
1600 - 1615, 1632 - 1655	PV Grounding Fault	<ol style="list-style-type: none"> <li>1. When the fault occurs, it is forbidden to directly disconnect the DC switch and unplug PV terminals when the direct current is greater than 0.5 A;</li> <li>2. Wait until the direct current of the inverter falls below 0.5 A, then disconnect the DC switch and unplug the faulty strings;</li> <li>3. Do not reinsert the faulty strings before the grounding fault is cleared;</li> <li>4. If the fault is not caused by the foregoing reasons and still exists, contact Sungrow Customer Service.</li> </ol>
1616	System Hardware Fault	<ol style="list-style-type: none"> <li>1. It is prohibited to disconnect the DC switch when the DC current is greater than 0.5 A when the fault occurs.</li> <li>2. Disconnect the DC switch only when the inverter DC side current drops below 0.5 A.</li> <li>3. It is prohibited to power up the inverter again. Please contact Sungrow Customer Service.</li> </ol>



Contact SUNGROW if the measures listed in the “**Troubleshooting Method**” column have been taken but the problem persists.

## 8.2 Maintenance

### 8.2.1 Maintenance Notices

#### DANGER

**Risk of inverter damage or personal injury due to incorrect service!**

- Be sure to use special insulation tools when perform high-voltage operations.
- Before maintenance, disconnect the AC circuit breaker on the grid side and then the DC switch. If a fault that may cause personal injury or device damage is found before maintenance, disconnect the AC circuit breaker and wait until the night before operating the DC switch. Otherwise, a fire inside the product or an explosion may occur, causing personal injuries.
- After the inverter is powered off for 25 minutes, measure the voltage and current with professional instrument. Only when there is no voltage nor current can operators who wear protective equipment operate and maintain the inverter
- Even if the inverter is shut down, it may still be hot and cause burns. Wear protective gloves before operating the inverter after it cools down.

#### DANGER

When maintaining the product, it is strictly prohibited to open the product if there is an odor or smoke or if the product appearance is abnormal. If there is no odor, smoke, or obvious abnormal appearance, repair or restart the inverter according to the alarm corrective measures. Avoid standing directly in front of the inverter during maintenance.

#### CAUTION

To prevent misuse or accidents caused by unrelated personnel: Post prominent warning signs or demarcate safety warning areas around the inverter to prevent accidents caused by misuse.

#### NOTICE

- Restart the inverter only after removing the fault that impairs safety performance.
- As the inverter contains no component parts that can be maintained, never open the enclosure, or replace any internal components.
- To avoid the risk of electric shock, do not perform any other maintenance operations beyond this manual. If necessary, contact SUNGROW for maintenance. Otherwise, the losses caused is not covered by the warranty.

**NOTICE**

Touching the PCB or other static sensitive components may cause damage to the device.

- Do not touch the circuit board unnecessarily.
- Observe the regulations to protect against electrostatic and wear an anti-static wrist strap.

**8.2.2 Disconnecting Inverter****⚠ CAUTION****Danger of burns!**

Even if the inverter is shut down, it may still be hot and cause burns. Wear protective gloves before operating the inverter after it cools down.

For maintenance or other service work, the inverter must be switched off.

Proceed as follows to disconnect the inverter from the AC and DC power sources. Lethal voltages or damage to the inverter will follow if otherwise.

**step 1** Disconnect the external AC circuit breaker and prevent it from inadvertent reconnection.

**step 2** Rotate the DC switch to the "OFF" position for disconnecting all of the PV string inputs.

**step 3** Wait about 25 minutes until the capacitors inside the inverter completely discharge.

**step 4** Ensure that the DC cable is current-free with a current clamp.

-- End

**8.2.3 Routine Maintenance**

Item	Method	Period
Device clean	<p>Check whether the air outlet and heat sink are blocked by dust and other objects.</p> <p>Check if the air inlet and outlet are normal. Clean the air inlet and outlet, if necessary.</p>	Six months to a year (depend on the dust contents in air)

Item	Method	Period
Fans	<p>Check whether there is a fan alarm on the App.</p> <p>Check whether there is any abnormal noise when the fan is rotating.</p> <p>Clean or replace the fans if necessary (see the following section).</p>	Once a year
Cable entry	<p>Check whether the cable entry is insufficiently sealed or the gap is excessively large, and reseal the entry when necessary.</p>	Once a year
Electrical connection	<p>Check whether cables are loose or fall off.</p> <p>Check whether the cable is damaged, especially the part in contact with the metal enclosure.</p>	Six months to a year
Surrounding vegetation	<p>Perform inspection and weeding before vegetation wilts.</p> <p>Clean the site promptly after weeding and do not pile the weed up around the inverter.</p>	Based on the local wilting season

### 8.2.4 Cleaning Air Inlet and Outlet

A significant amount of heat is generated when the inverter is working.

In order to maintain good ventilation, please check to make sure the air inlet and outlet are not blocked.

Clean the air inlet and outlet with soft brush or vacuum cleaner if necessary.

### 8.2.5 Fan Maintenance

#### DANGER

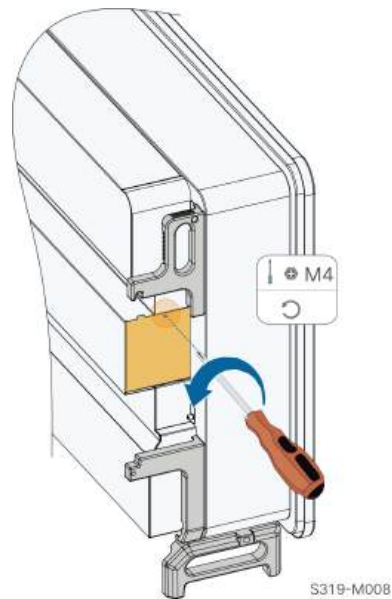
- **Power off the inverter and disconnect it from all power supplies before maintaining fans.**
- **After the inverter is powered off for 25 minutes, measure the voltage and current with professional instrument. Only when there is no voltage nor current can operators who wear protective equipment operate and maintain the inverter.**
- **Fan maintenance must be performed by professionals.**

Fans inside the inverter are used to cool the inverter during operation. If the fans do not operate normally, the inverter may not be cooled down and inverter efficiency may decrease. Therefore, it is necessary to clean dirty fans and replace the broken fans in a timely manner.

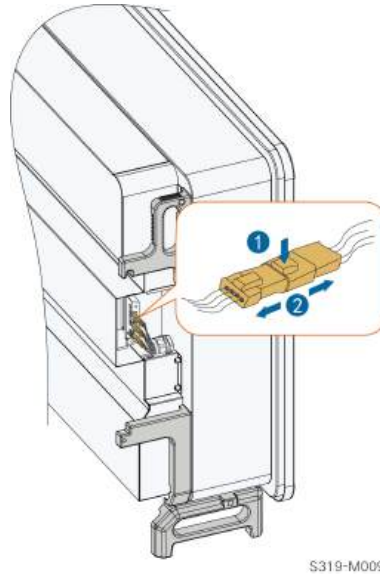
The operation procedure is as follows:

**step 1** Stop the inverter (see [8.2.2 Disconnecting Inverter](#)).

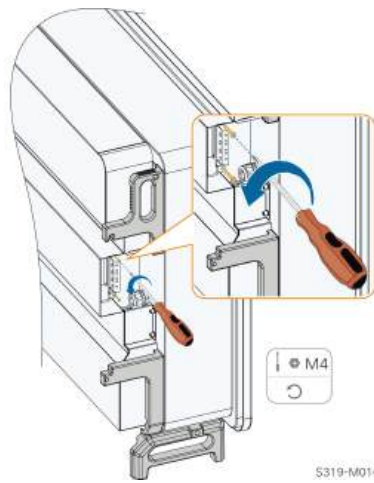
**step 2** Loosen the screw on the sealing plate of the fan module.



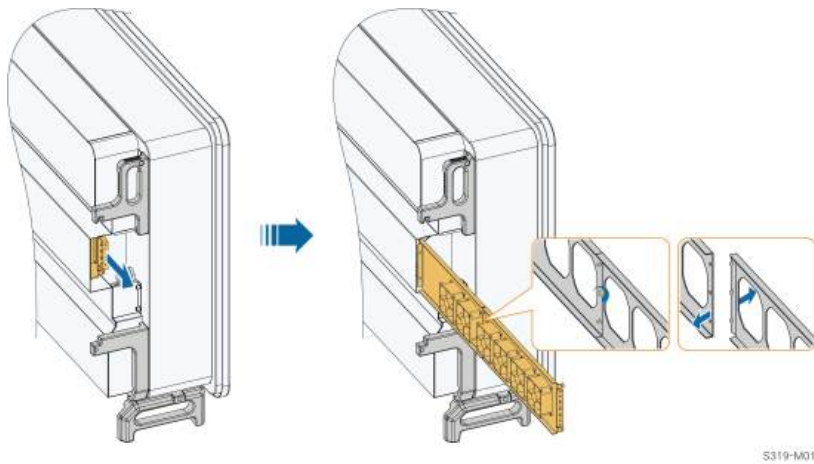
**step 3** Press the tab of the latch hook, unplug the cable connection joint outwards, and loosen the screw on the fan holder.



**step 4** Loosen screws on the sides of fans.



**step 5** Pull out the fans. Clean them with a soft brush or vacuum cleaner, and replace them when necessary.



S319-M011



If there is not enough space, pull out part of the fans and remove the screws between the two fans.

-- End

### 8.2.6 DC Switch Maintenance



The DC switch is able to interrupt the circuits automatically when the device detects reverse polarity or back-feeding in the strings or a fault inside the inverter.

In case the DC switch on the inverter turns to the "OFF" position automatically, please proceed with the following steps:

- step 1** Check the fault information on the iSolarCloud App or in the energy monitoring system.
- step 2** In case of reverse polarity or back-feeding in the strings connected to the inverter, please perform troubleshooting according to the fault alarm information. You can close the DC switch after the fault is cleared.
- step 3** In case of a fault inside the inverter, please contact SUNGROW for technical support.

-- End

## 8.3 Inverter Disposal

### 8.3.1 Dismantling the Inverter

#### **⚠ CAUTION**

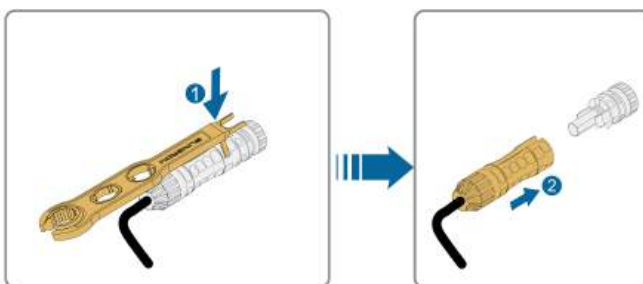
**Risk of burn injuries and electric shock!**

**After the inverter is powered off for 25 minutes, measure the voltage and current with professional instrument. Only when there is no voltage nor current can operators who wear protective equipment operate and maintain the inverter.**



- Before dismantling the inverter, disconnect the inverter from both AC and DC power sources.
- If there are more than two layers of inverter DC terminals, dismantle the outer DC connectors before dismantling the inner ones.
- If the original packing materials are available, put the inverter inside them and then seal them using adhesive tape. If the original packing materials are not available, put the inverter inside a cardboard box suitable for the weight and size of this inverter and seal it properly.

**step 1** Refer to [5 Electrical Connection](#) to disconnect all cables in reverse steps. In particular, when removing the DC connector, use a connector wrench to loosen the locking parts and install water-proof plugs.



**step 2** Refer to [4 Mechanical Mounting](#), to dismantle the inverter in reverse steps.

**step 3** If necessary, remove the wall-mounting bracket from the wall.

**step 4** If the inverter will be used again in the future, please refer to [3.3 Inverter Storage](#) for a proper conservation.

- - End

### 8.3.2 Disposal of Inverter

Users take the responsibility for the disposal of the inverter.

**⚠ WARNING**

**Please scrap the inverter in accordance with relevant local regulations and standards to avoid property losses or casualties.**

**NOTICE**

**Some parts of the inverter may cause environmental pollution. Please dispose of them in accordance with the disposal regulations for electronic waste applicable at the installation site.**

# 9 Appendix

## 9.1 Technical Data

Parameters	SG320HX-20	SG350HX-20
<b>Input (DC)</b>		
Max. PV input voltage	1500 V	
Min. PV input voltage / Start-up input voltage	500 V / 550 V	
Nominal PV input voltage	1080 V	
MPP voltage range	500 V – 1500 V	
No. of independent MPP inputs	6	
Max. number of input connector per MPPT	5	
Max. PV input current	6 * 75 A	
Max. DC short-circuit current per MPPT	6 * 125 A	
<b>Output (AC)</b>		
AC output power	352 kVA @ 30 °C / 320 kVA @ 40 °C / 300 kVA @ 51 °C	352 kVA @ 30 °C / 320 kVA @ 40 °C / 295 kVA @ 50 °C
Max. AC output current	254 A	
Nominal AC voltage	3 / PE, 800 V	
AC voltage range	640 – 920V	
Nominal grid frequency / Grid frequency range	50 Hz / 45 – 55 Hz, 60 Hz / 55 – 65 Hz	
THD	< 1 % ( Rated Condition )	
DC current injection	< 0.5 % In	
Power factor at nominal power / Adjustable power factor	> 0.99 / 0.8 leading – 0.8 lagging	
Feed-in phases / Connection phases	3 / 3	
<b>Efficiency</b>		
Max. efficiency / European efficiency	99.02 % / 98.8 %	

Parameters	SG320HX-20	SG350HX-20
<b>Protection</b>		
DC reverse connection protection		Yes
AC short circuit protection		Yes
Leakage current protection		Yes
Grid monitoring		Yes
Ground fault monitoring		Yes
DC switch / AC switch		Yes / No
PV string current monitoring		Yes
Q at night function		Yes
Anti-PID and PID recovery function		Optional
Surge protection	DC Type II / AC Type II	
<b>General Data</b>		
Dimensions	1148 * 779 * 371 mm	
Weight <sup>(1)</sup>	≤ 106 kg	
Isolation method	Transformerless	
Degree of protection	IP66	
Power consumption at night	< 6 W	
Operating ambient temperature range <sup>(2)</sup>	-30 to 60 °C	
Allowable relative humidity range	0 – 100 %	
Cooling method	Smart forced air cooling	
Max. operating altitude	5000 m (> 4000 m derating)	
Display	LED, Bluetooth+App	
Communication	RS485 / PLC	
DC connection type	Evo2	
AC connection type	Support OT/DT terminal (Max. 400 mm <sup>2</sup> )	
Compliance	IEC 62109, IEC 61727, IEC 62116, IEC 60068, IEC 61683, EN 50549-2	IEC 62109, IEC 61727, IEC 62116, IEC 60068, IEC 61683, VDE- AR-N4110:2018, VDEAR-N 4120:2018, EN 50549-2, UNE 206007-1:2013, P.O.12.3, UTE C15-712-1:2013

Parameters	SG320HX-20	SG350HX-20
Grid Support	Q at night function, LVRT, HVRT, active & reactive power control and power ramp rate control, Q-U control, P-f control	
Parameters	SG305HX	
<b>Input (DC)</b>		
Max. PV input voltage	1500 V	
Min. PV input voltage / Start-up input voltage	500 V / 550 V	
Nominal PV input voltage	1080 V	
MPP voltage range	500 V – 1500 V	
No. of independent MPP inputs	6	
Max. number of input connector per MPPT	5	
Max. PV input current	6 * 75 A	
Max. DC short-circuit current per MPPT	6 * 125 A	
<b>Output (AC)</b>		
AC output power	305 kVA @ 30 °C / 305 kVA @ 40 °C / 275 kVA @ 50 °C	
Max. AC output current	220 A	
Nominal AC voltage	3 / PE, 800 V	
AC voltage range	640 – 920V	
Nominal grid frequency / Grid frequency range	50 Hz / 45 – 55 Hz, 60 Hz / 55 – 65 Hz	
THD	< 1 % ( Rated Condition )	
DC current injection	< 0.5 % In	
Power factor at nominal power / Adjustable power factor	> 0.99 / 0.8 leading – 0.8 lagging	
Feed-in phases / Connection phases	3 / 3	
<b>Efficiency</b>		
Max. efficiency / European efficiency	99.02 % / 98.8 %	
<b>Protection</b>		

Parameters	SG305HX
DC reverse connection protection	Yes
AC short circuit protection	Yes
Leakage current protection	Yes
Grid monitoring	Yes
Ground fault monitoring	Yes
DC switch / AC switch	Yes / No
PV string current monitoring	Yes
Q at night function	Yes
Anti-PID and PID recovery function	Optional
Surge protection	DC Type II / AC Type II
<b>General Data</b>	
Dimensions (W*H*D)	1148 mm * 779 mm * 371 mm
Weight <sup>(1)</sup>	≤ 106 kg
Isolation method	Transformerless
Degree of protection	IP66
Power consumption at night	< 6 W
Operating ambient temperature range	-30 to 60 °C
Allowable relative humidity range	0 – 100 %
Cooling method	Smart forced air cooling
Max. operating altitude	5000 m (> 4000 m derating)
Display	LED, Bluetooth+App
Communication	RS485 / PLC
DC connection type	Evo2
AC connection type	Support OT/DT terminal (Max. 400 mm <sup>2</sup> )
Compliance	IEC 62109, IEC 61727, IEC 62116, IEC 60068, IEC 61683, EN 50549-2, UNE 206007-1:2013, P.O.12.3
Grid Support	Q at night function, LVRT, HVRT, active & reactive power control and power ramp rate control, Q-U control, P-f control

Note (1): Due to the multi-supplier for some key components, the actual weight may have a ±8% deviation, please refer to the actually delivered product.

## 9.2 Quality Assurance

When product faults occur during the warranty period, SUNGROW will provide free service or replace the product with a new one.

### Evidence

During the warranty period, the customer shall provide the product purchase invoice and date. In addition, the trademark on the product shall be undamaged and legible. Otherwise, SUNGROW has the right to refuse to honor the quality guarantee.

### Conditions

- After replacement, unqualified products shall be processed by SUNGROW.
- The customer shall give SUNGROW a reasonable period to repair the faulty device.

### Exclusion of Liability

In the following circumstances, SUNGROW has the right to refuse to honor the quality guarantee:

- The free warranty period for the whole machine/components has expired.
- The device is damaged during transport.
- The device is incorrectly installed, refitted, or used.
- The device operates in harsh conditions beyond those described in this manual.
- The fault or damage is caused by installation, repairs, modification, or disassembly performed by a service provider or personnel not from SUNGROW.
- The fault or damage is caused by the use of non-standard or non-SUNGROW components or software.
- The installation and use range are beyond stipulations of relevant international standards.
- The damage is caused by unexpected natural factors.

For faulty products in any of above cases, if the customer requests maintenance, paid maintenance service may be provided based on the judgment of SUNGROW.

## 9.3 Contact Information

In case of questions about this product, please contact us.

We need the following information to provide you the best assistance:

- Model of the device
- Serial number of the device
- Fault code/name
- Brief description of the problem

For detailed contact information, please visit: <https://en.sungrowpower.com/contactUS>

**SUNGROW**

Sungrow Power Supply Co., Ltd.  
[www.sungrowpower.com](http://www.sungrowpower.com)