

Assembly Manual

# MiniRail MK2 System



Connecting Strength

[k2-systems.com](http://k2-systems.com)

# Content

• Tools overview	3
• General safety information	4
• The following guidelines apply	5
· Planning with K2 Base	5
· Roof requirements	5
· Structural requirements	5
· Important mounting instructions	5
· Basic components	6
· 5°-Aufständigung mit MiniFive	7
• Assembly Portrait	8
• Assembly Landscape	11
• Assembly elevation	13
· MiniFive 5°-elevation	13
· Roof-parallel elevation with RailUp	15
• Module frame earthing with TerraGrif	16
· TerraGrif QL or K2SZ	16
· TerraGrif PL for MiniFive Front/End	16
• Notes	17

## Quality tested - several certifications

K2 Systems stands for secure connections, highest quality and precision. Our customers and business partners have known that for a long time. Independent institutes have tested, confirmed and certified our capabilities and components.

Please find our quality and product certificates under:

[k2-systems.com](https://www.k2-systems.com)

# Tools overview

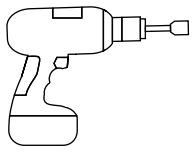

6 mm



6 mm

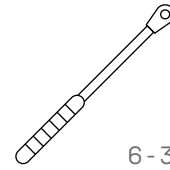

6 - 30 Nm  
(4.5 - 22.2 lb-ft)



6 mm

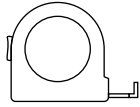

≥3.0 m



≥6.0 m

## Digitale Toolbox



**Do you already know our digital services?** Use our K2 Roof Check App now and record the first important data directly at the customer or project site.

Simply transfer the data to our online planning software K2 Base. Here you can plan your project easily, safely and quickly. You receive a detailed project report with assembly plan and static report.

The K2+ interface enables seamless project data transfer to the planning tools of other manufacturers. With the K2 DocuApp, project documentation is done quickly and easily - without annoying paperwork.

**Get started and register now:**

[docuapp.k2-systems.com](https://docuapp.k2-systems.com) →

[base.k2-systems.com](https://base.k2-systems.com) →

# General safety information

Please note that our general mounting instructions must be followed at all times and can be viewed online at [k2-systems.com](https://www.k2-systems.com).

- The equipment may only be installed and operated by qualified and adequately trained installers.
- Prior to installation, ensure that the product complies with on-site static loading requirements. For roof-mounted systems, the roof load-bearing capacity must always be checked.
- National and local building regulations and environmental requirements must be adhered to.
- Compliance with health and safety regulations, accident prevention guidelines and applicable standards is required.
  - Protective equipment such as safety helmet, boots and gloves must be worn.
  - Roofing works must be in accordance with roofing regulations utilising fall protection safeguards when eaves height exceeds 3 m.
  - At least two people must be present for the duration of the installation work in order to provide rapid assistance in the event of an emergency.
- K2 mounting systems are continuously developed and improved and the installation process may thereby change at any time. Prior to installation consult our website at [k2-systems.com](https://www.k2-systems.com) for up-to-date instructions. We can send you the latest version on request.
- The assembly instructions of the module manufacturer must be adhered to.
- Equipotential bonding/grounding/earthing between individual parts is to be performed according to country specific standards, as well as national laws and regulations.
- At least one copy of the assembly instructions should be available on site throughout the duration of the installation.
- Failure to adhere to our general safety and assembly instructions and not using all system components, K2 is not liable for any resulting defects or damages. We do not accept liability for any damage resulting in the use of competitor's parts. Warranty is excluded in such cases.
- German law shall apply excluding the UN Convention on CISG. Place of venue is Stuttgart. Our General Terms of Business apply.
- If all safety instructions are adhered to and the system is correctly installed, there is a product warranty entitlement of 12 years! We strongly recommend reviewing our terms of guarantee, which can be viewed at [k2-systems.com](https://www.k2-systems.com). We will also send this information on request.
- Dismantling of the system is performed in reverse order to the assembly.
- K2 stainless steel components are available in different corrosion resistance classes. Each structure or component must be carefully checked for possible corrosion exposure.

# The following guidelines apply



The MiniRail MK2 system can be used without further testing by K2 systems in the following standard conditions. The system is also suitable for higher requirements. However, if a value exceeds the standard conditions, please contact K2 Systems.



## Planning with K2 Base

We recommend our free online software K2 Base for the planning. In five steps, you can plan the right assembly system and get a construction recommendation, parts list and the structural analysis report. Simply register and start planning:

[base.k2-systems.com](http://base.k2-systems.com)



## Roof requirements

- Trapezoidal sheet metal thickness
  - Aluminium  $\geq 0,5$  mm (with a tensile strength of  $165 \text{ N/mm}^2$ )
  - Steel  $\geq 0,4$  mm (S235 acc. DIN EN 10025-1)
- Min. 22 mm crest width (the project-specific minimum high crest width dimension can be found in the Base report)
- High crest distance 101 - 350 mm
- Flush area surrounding the bore hole:  $\geq 20$  mm
- Roof pitch regularly: 5 - 75°



## Structural requirements

- The static verification of components is automatically calculated for each location using our Base planning software
- Sufficient holding force of the roof covering on the support or substructure



## Important mounting instructions

- On-site general standards and regulations for lightning protection must be observed and consultation with a specialist to create a lightning protection concept is recommended (use lightning protection clamp if necessary).
- MiniFive elevation: The exact mounting angle deviates slightly from 5° depending on the module width. This angle decreases with higher module widths.
- We recommend a thermal separation after maximum of 17.6 m.
- If the trapezoidal sheet is fastened with storm washers, please do not fasten the MiniRails on the storm washers! Spacing must be measured beforehand.
- Module frame heights
  - K2 Clamps: 25 - 40 mm
  - OneMid/OneEnd: 30 - 42 mm
- Adhere to module manufacturer recommendations for clamping area and module installation (see module manufacturer instructions) - tightening torque 14 Nm with M8 screw.
- Fasten the MiniRail to trapezoidal sheets with building approved self-tapping screws.
- No pre-drilling required! Pre-drill only with overlapping sheets to reduce spacing.

# Components

## Basic components

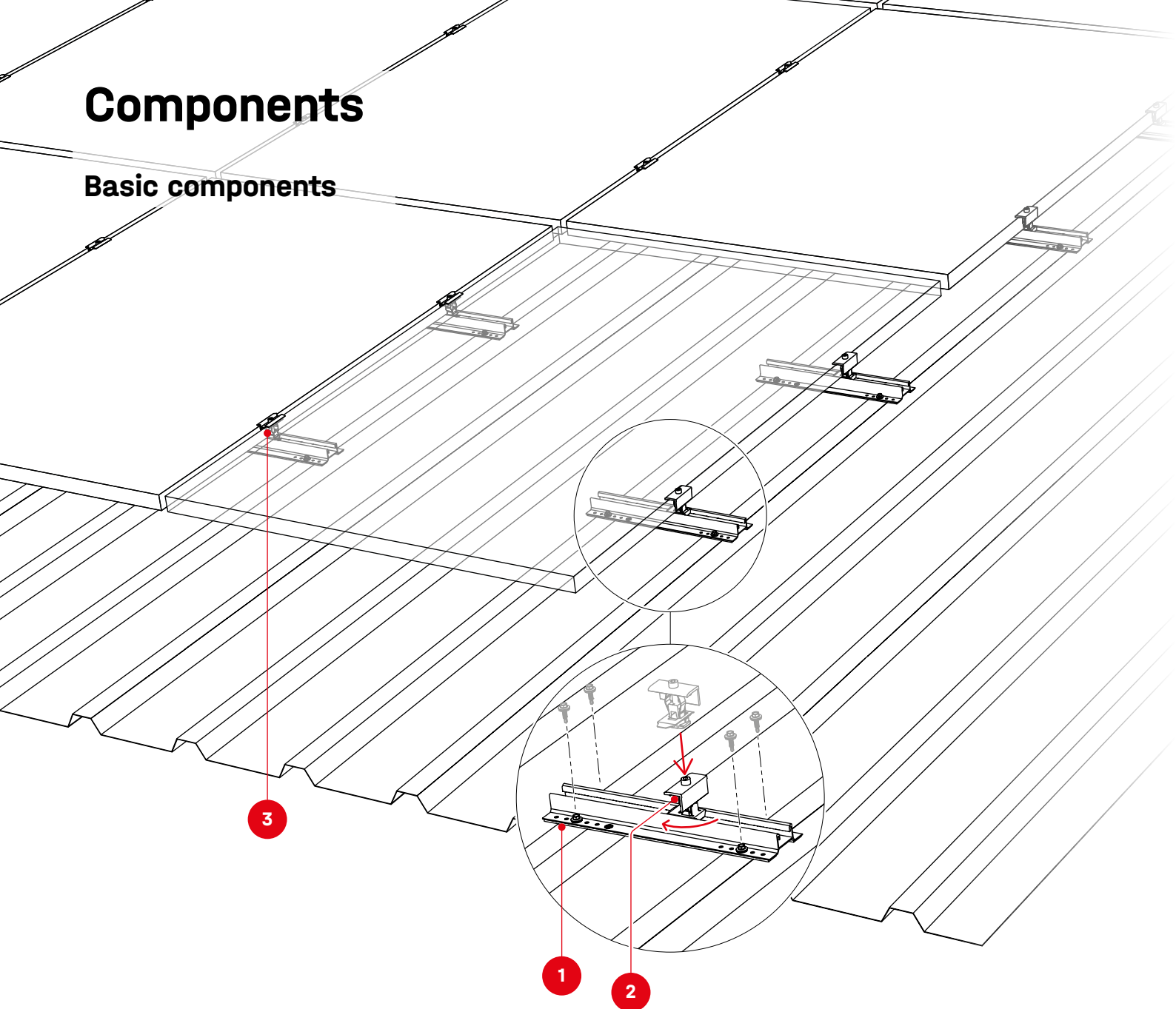

**1** 2004211  
**MiniRail MK2 Set**

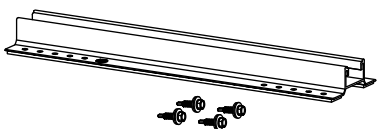

**2** 2004147 / 2004149  
**K2 Clamp EC 25 - 40 mm**  
silver/black

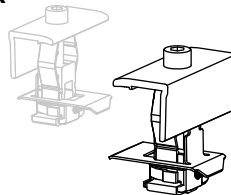

**3** 2004146 / 2004148  
**K2 Clamp MC 25 - 40 mm**  
silver/black

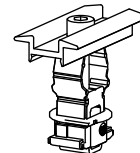

### Alternatively

2002514 / 2002589  
**OneEnd 30 - 42 mm**  
silver/black

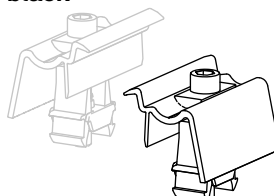

2003071 / 2003072  
**OneMid 30 - 42 mm**  
silver/black

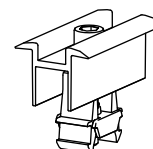

# 5°-Aufständerung mit MiniFive

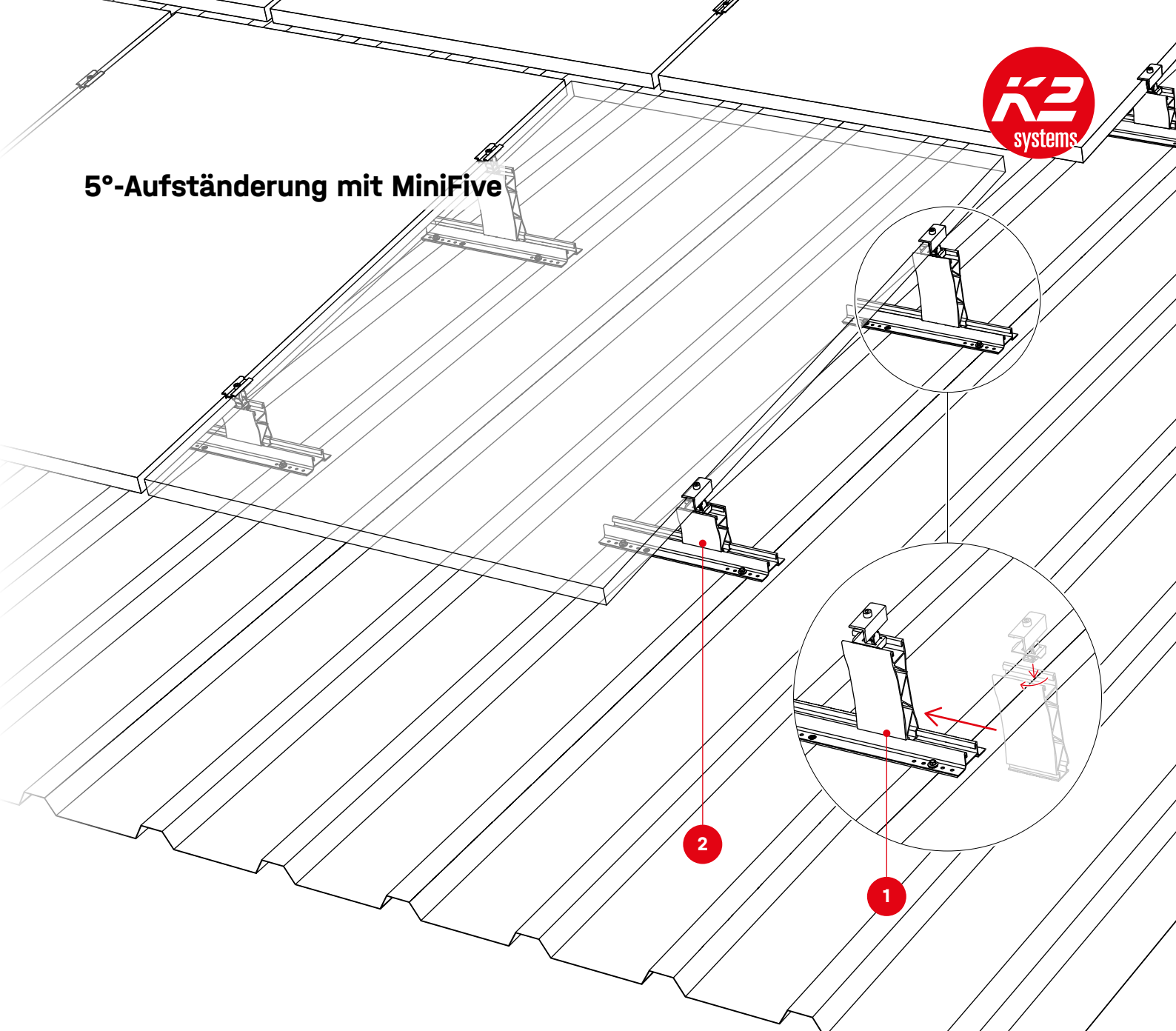

1/2

2004212 / 2004213  
**MiniFive MK2**  
 Front / End

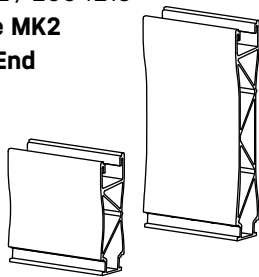

2003379  
**MiniFive Stop Set**

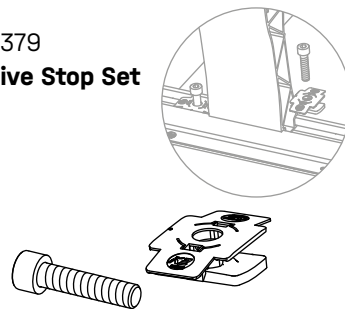

**Prescribed placement of MiniRail with MiniFive Front und End**



Portrait

## Optional

2003191  
**RailUp Set**

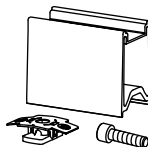

2004102  
**TerraGrif PL**

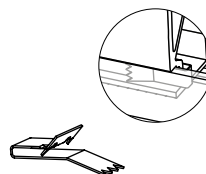

2004231 / 2001881  
**TerraGrif QL/K2SZ**

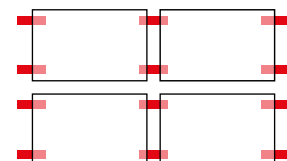

Landscape  
 Approval of module manufacturer required!

# Assembly Portrait

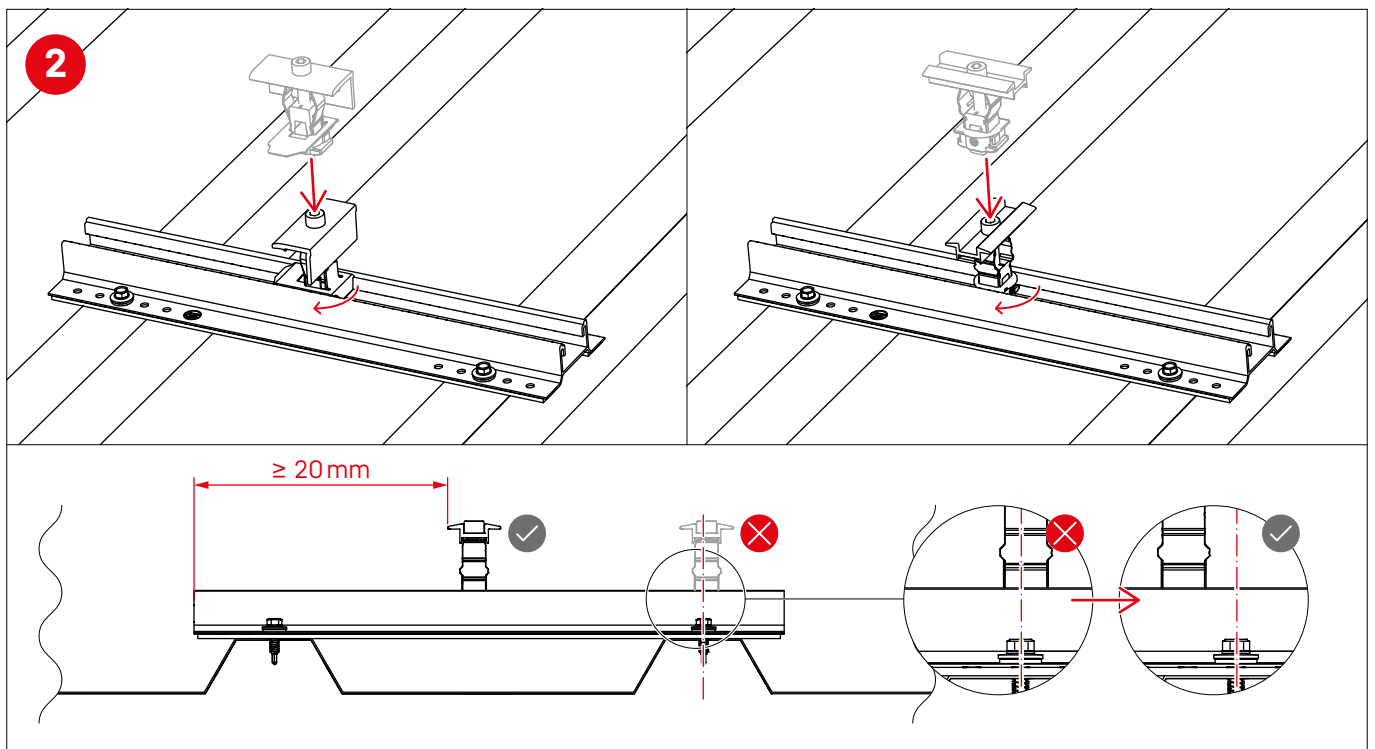
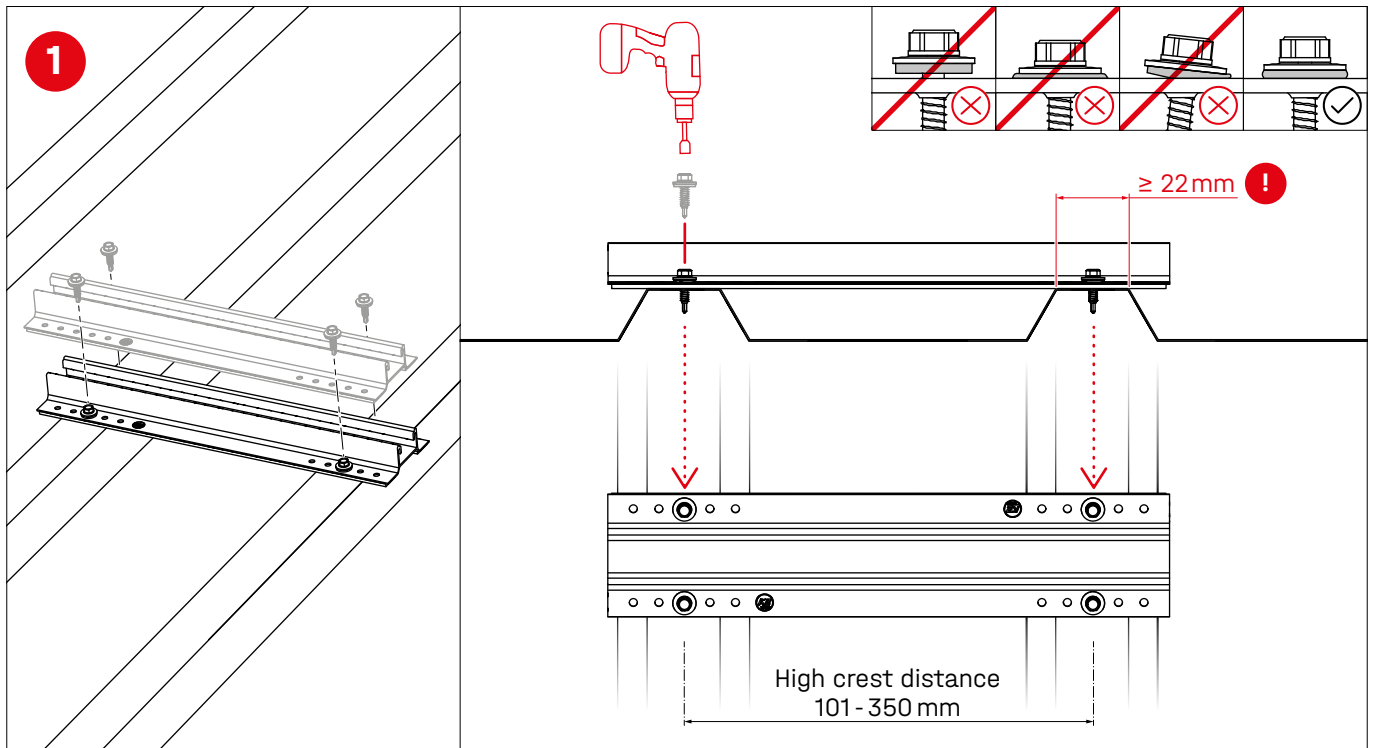

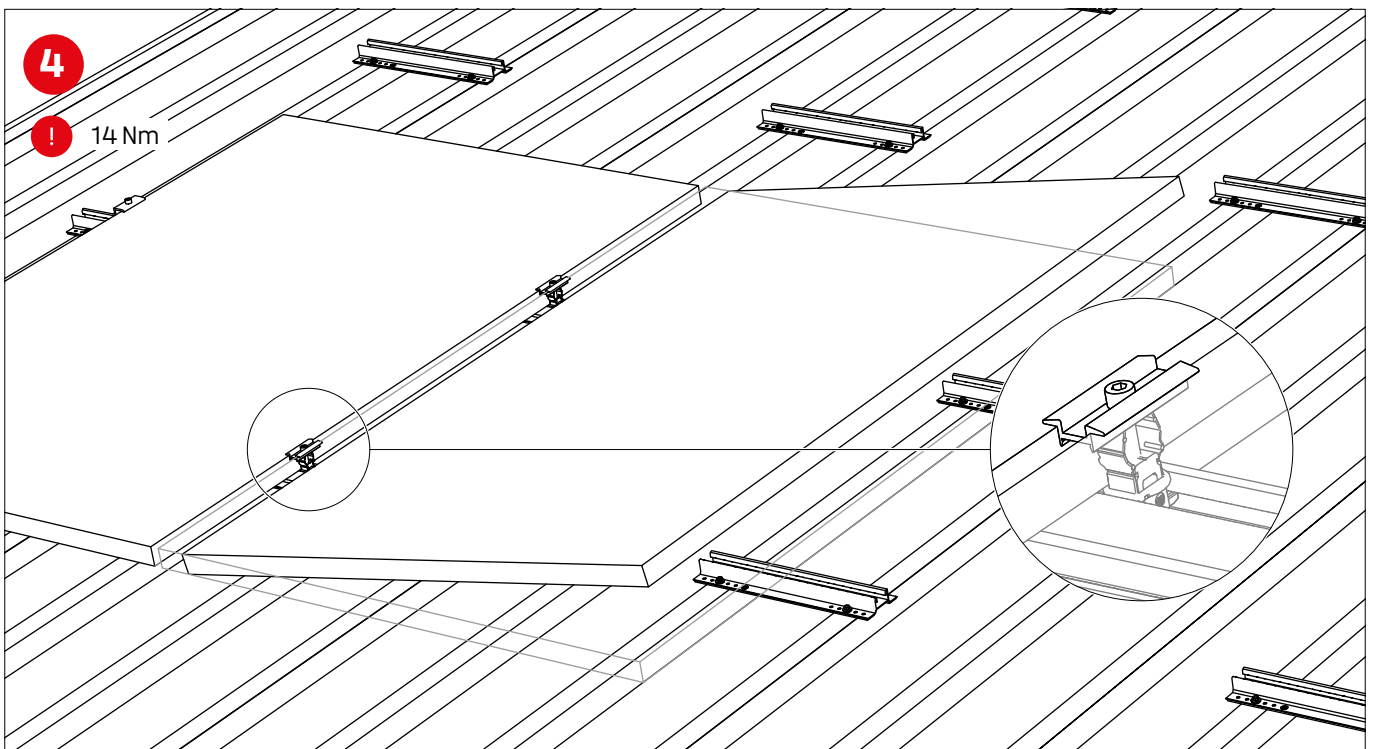
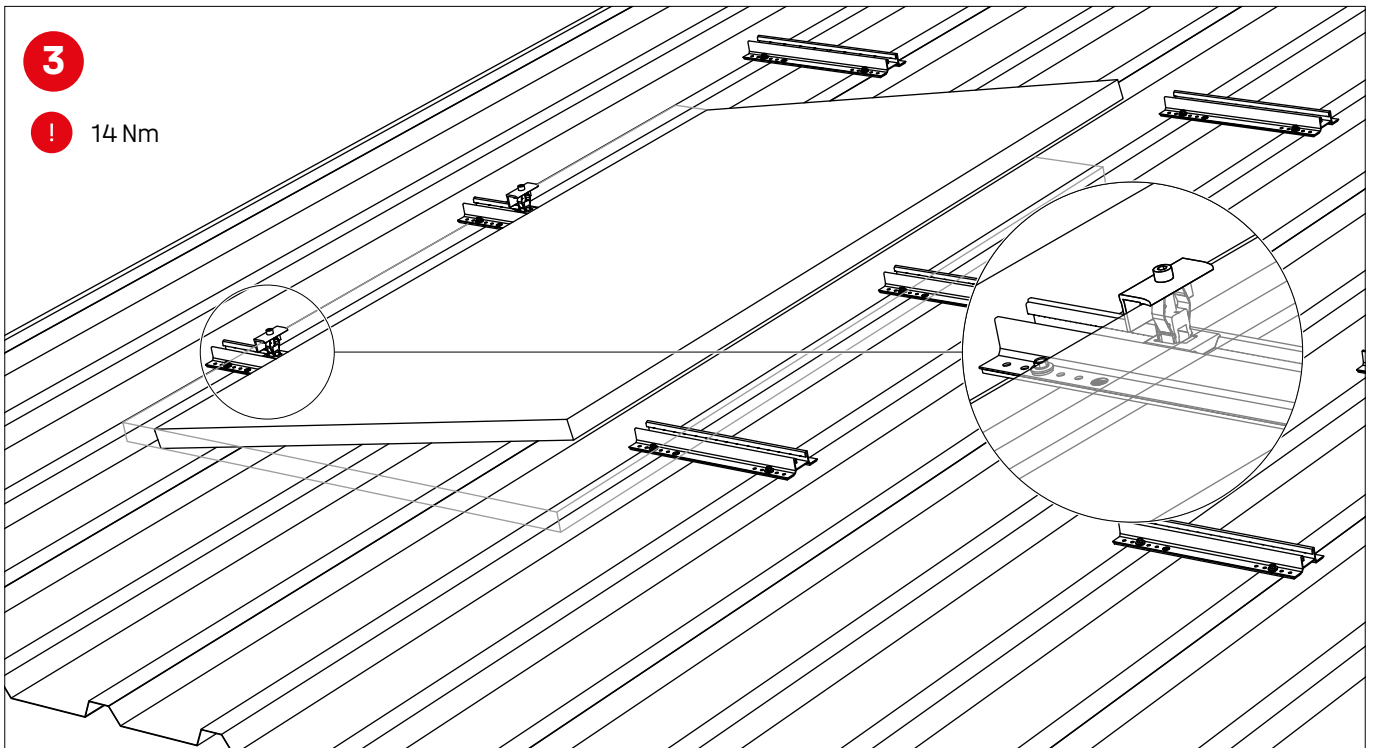

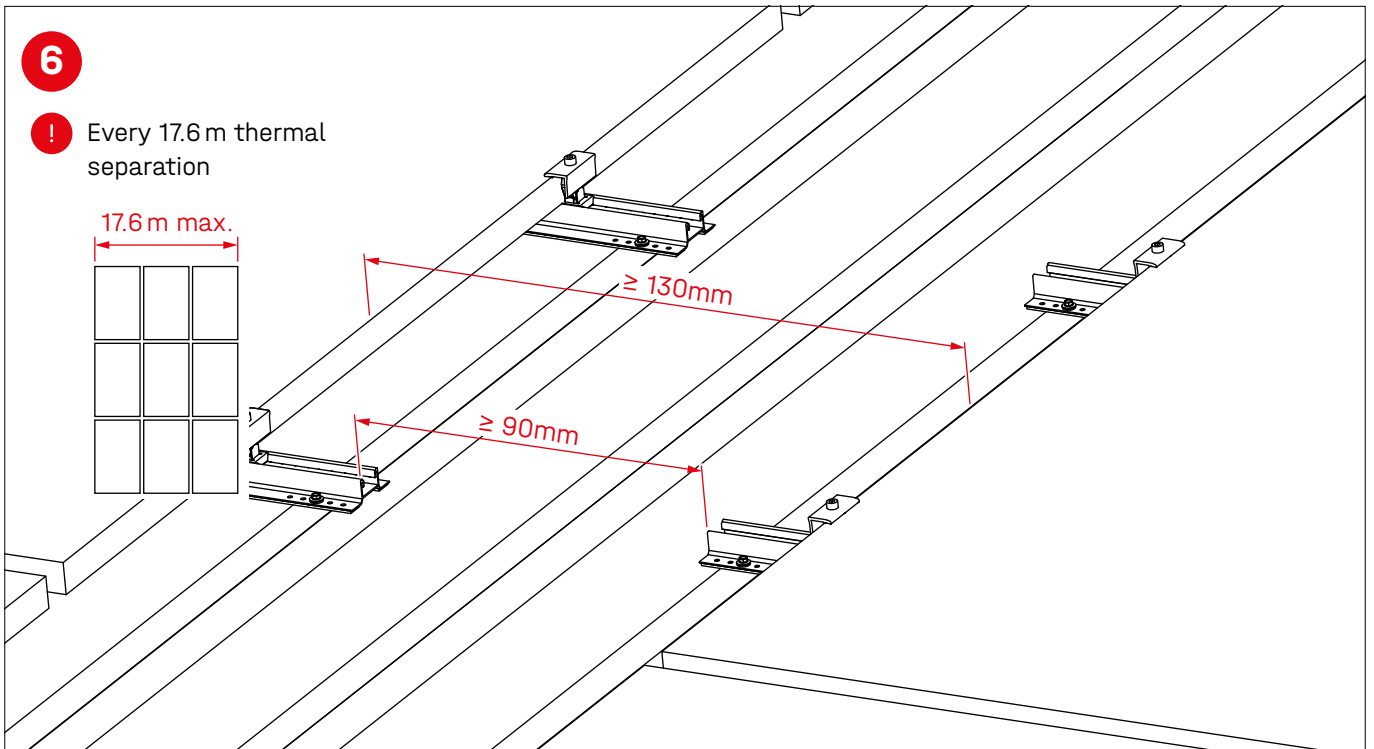
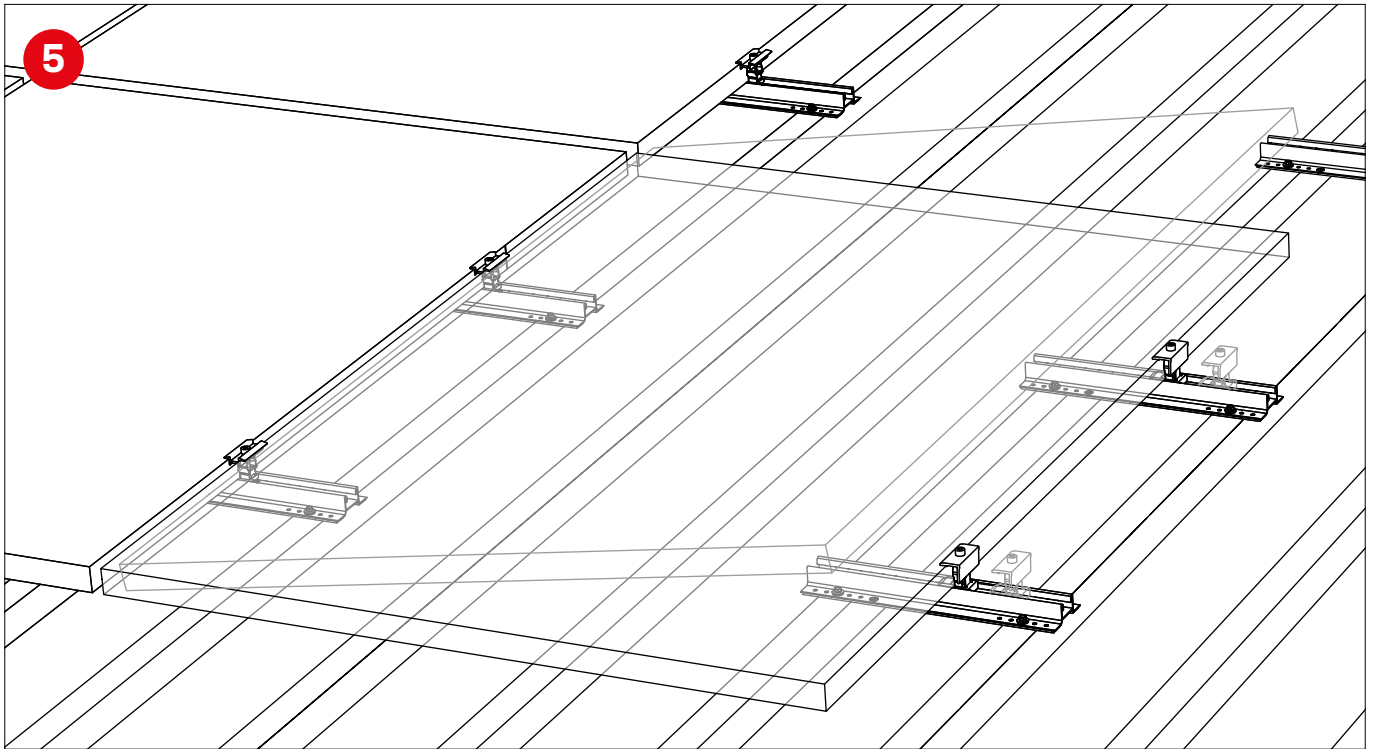

# Assembly Landscape

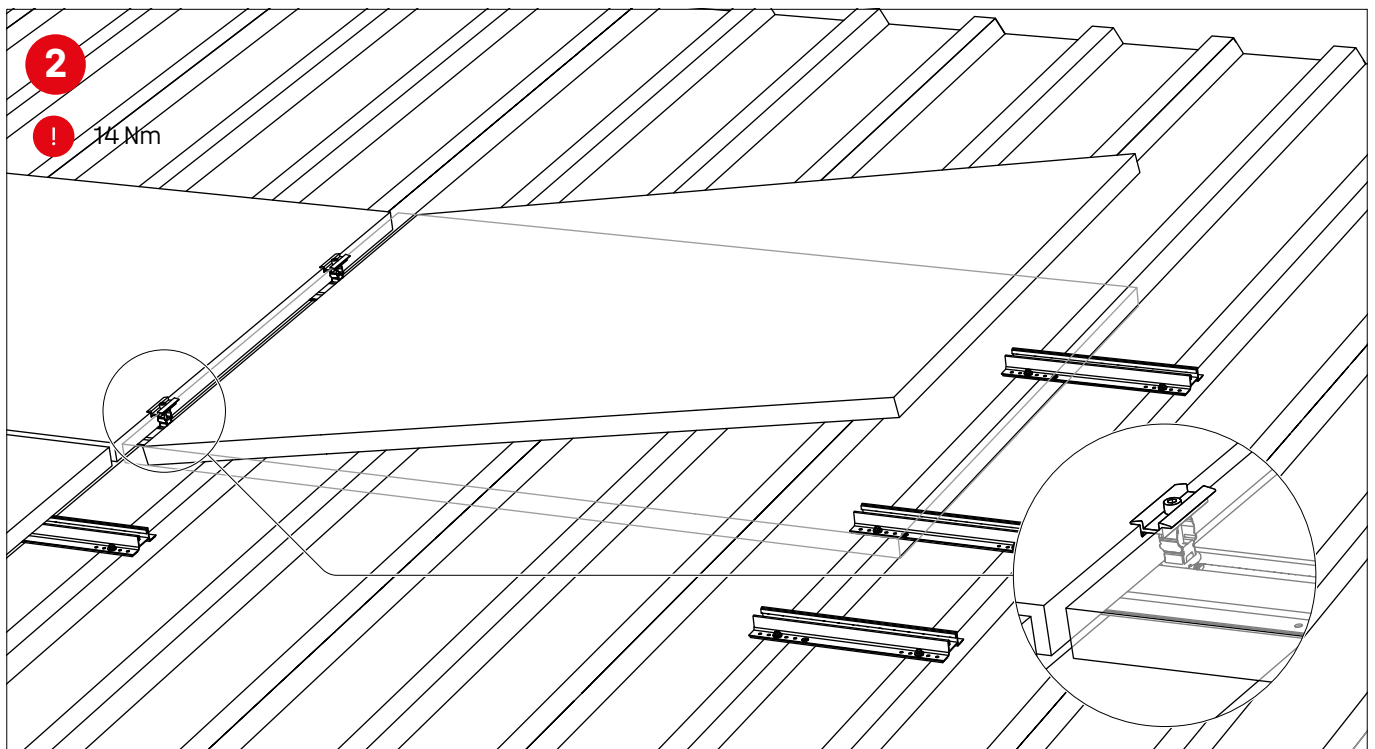
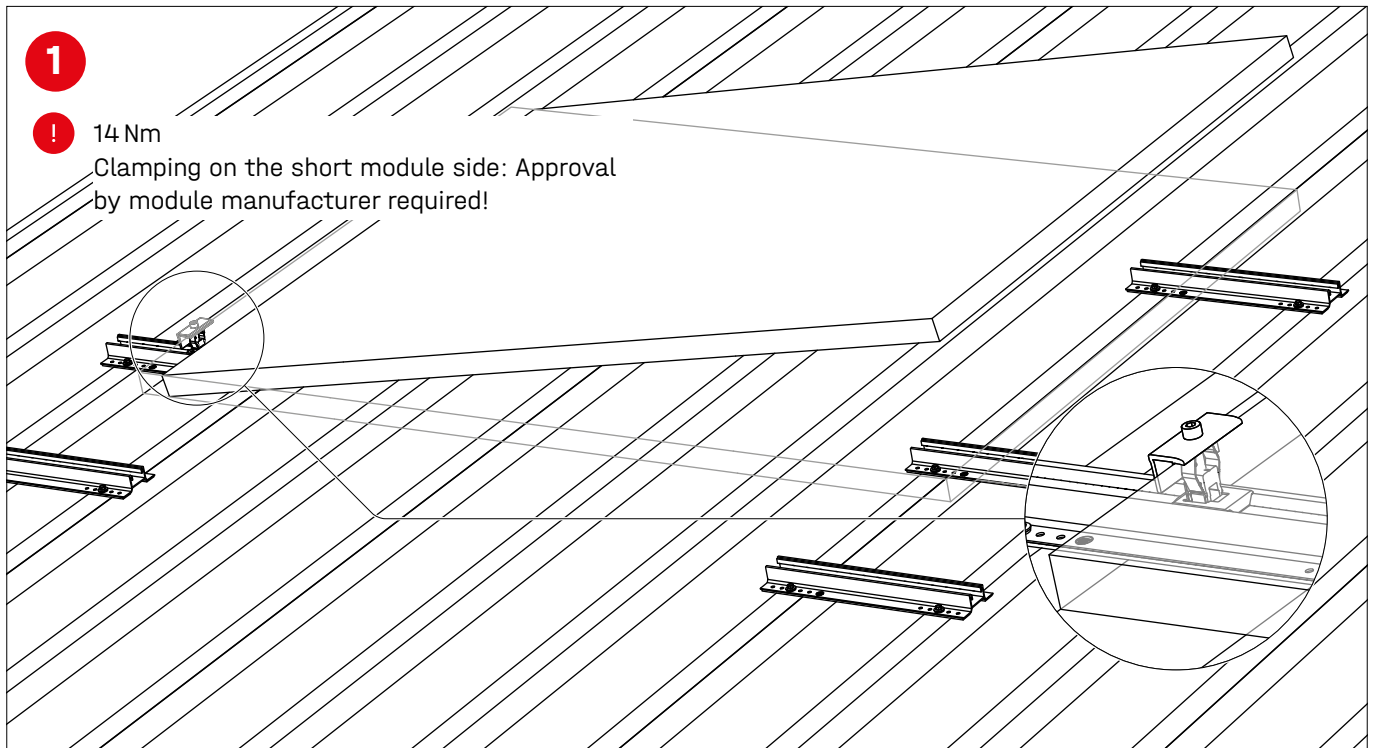

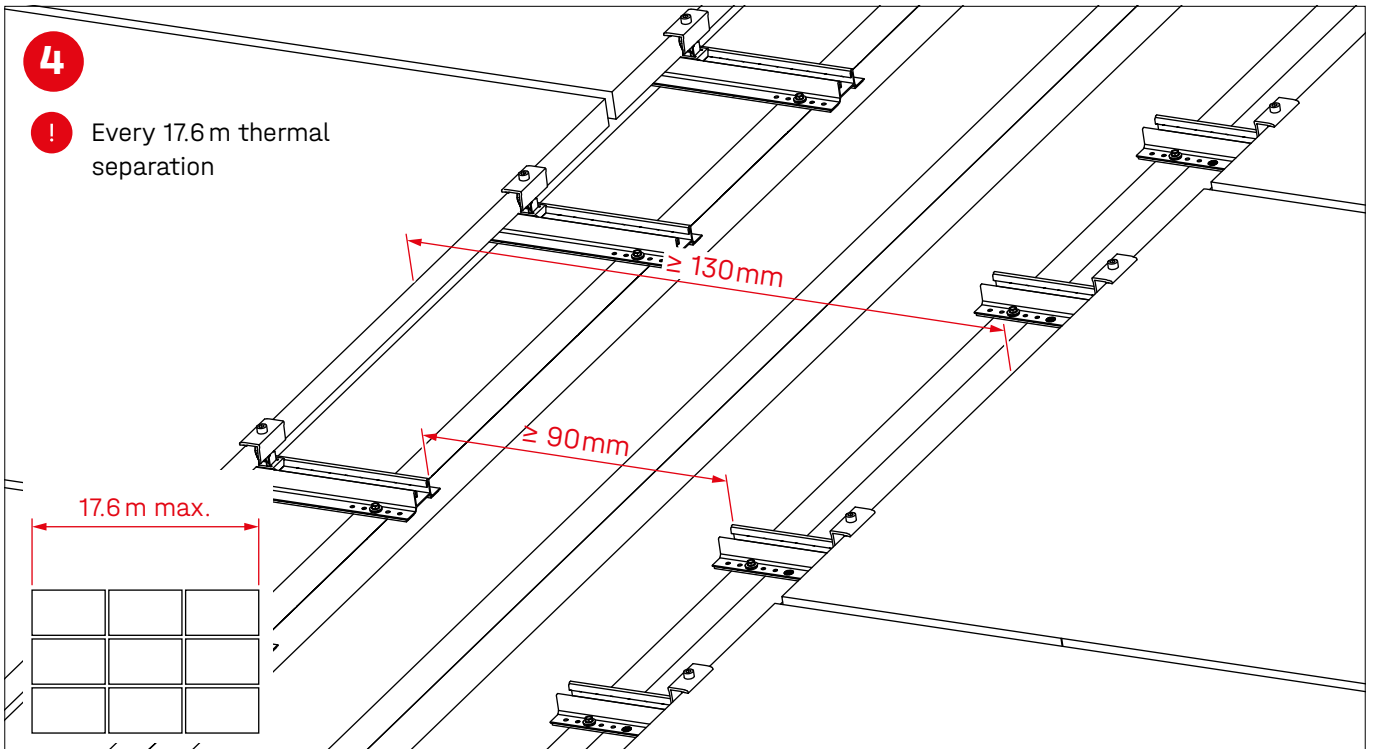
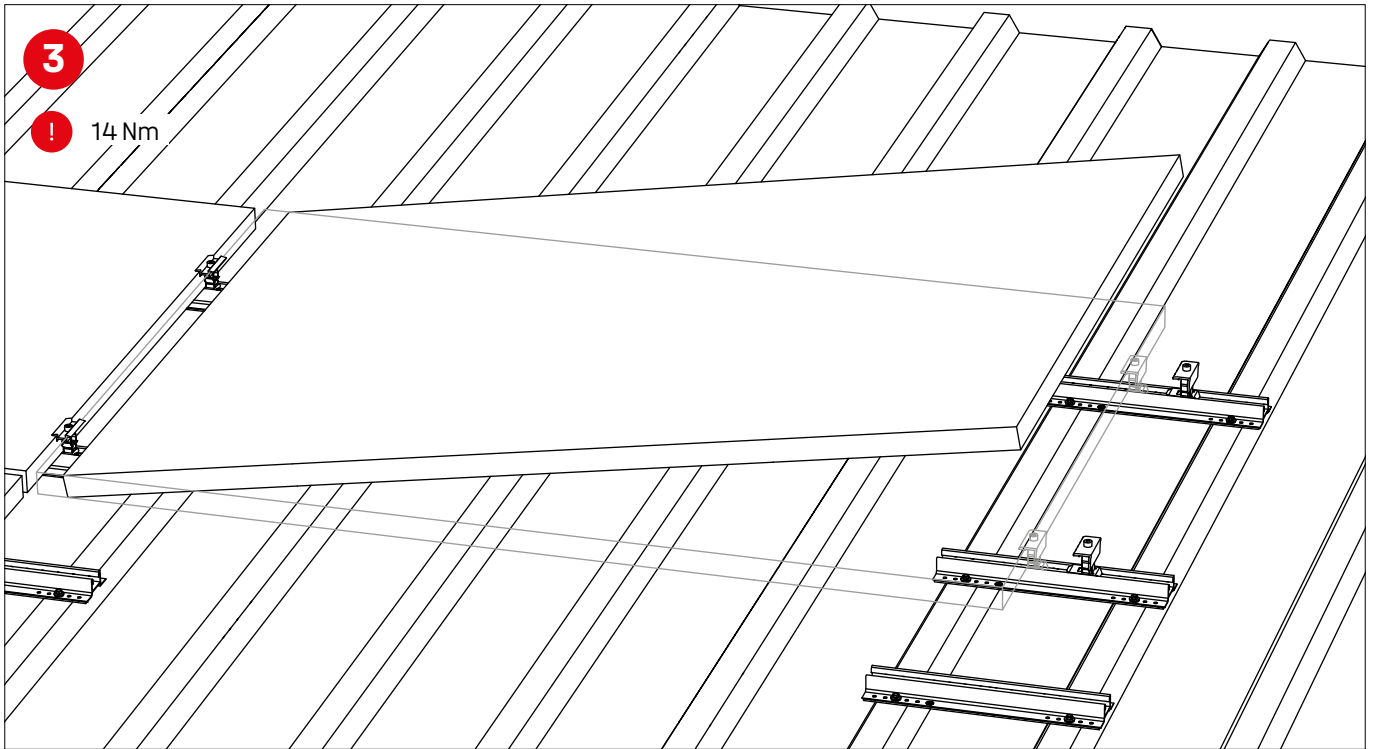

# Assembly elevation



## MiniFive 5°-elevation

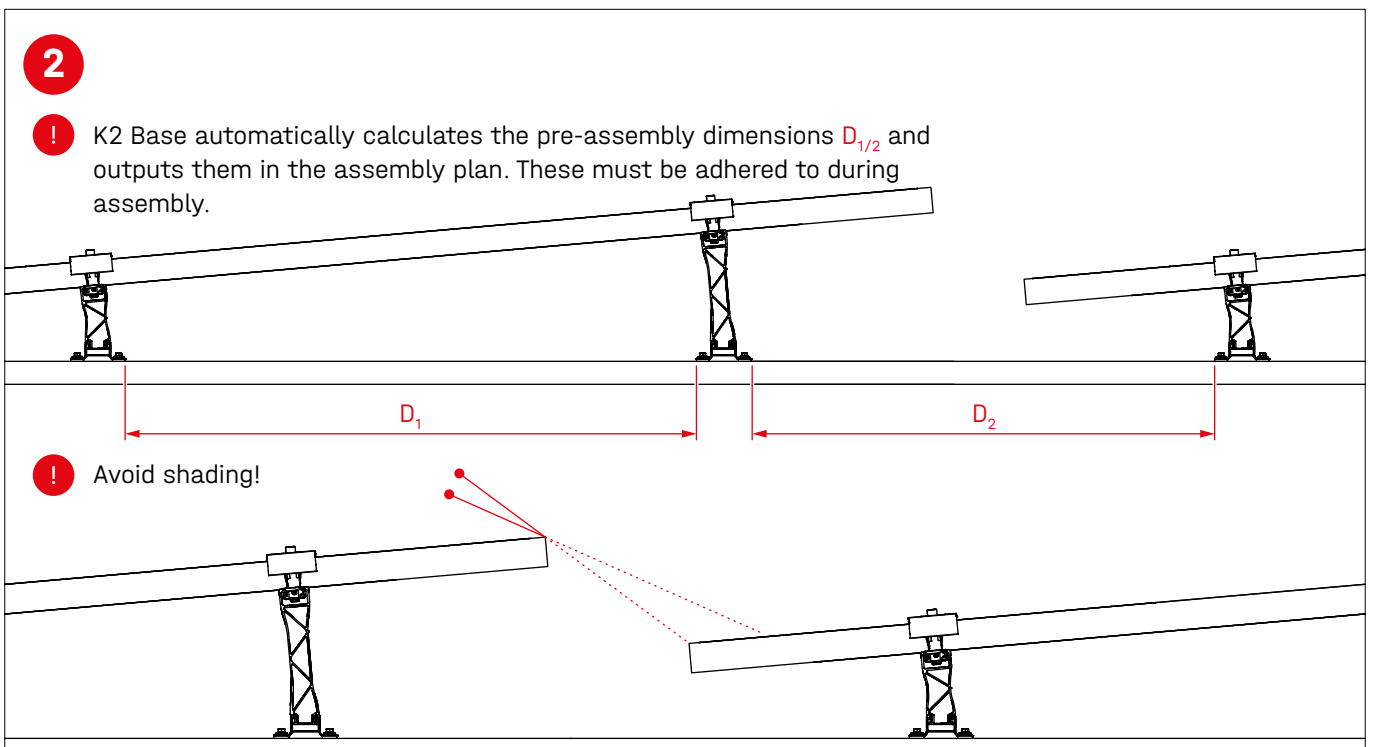
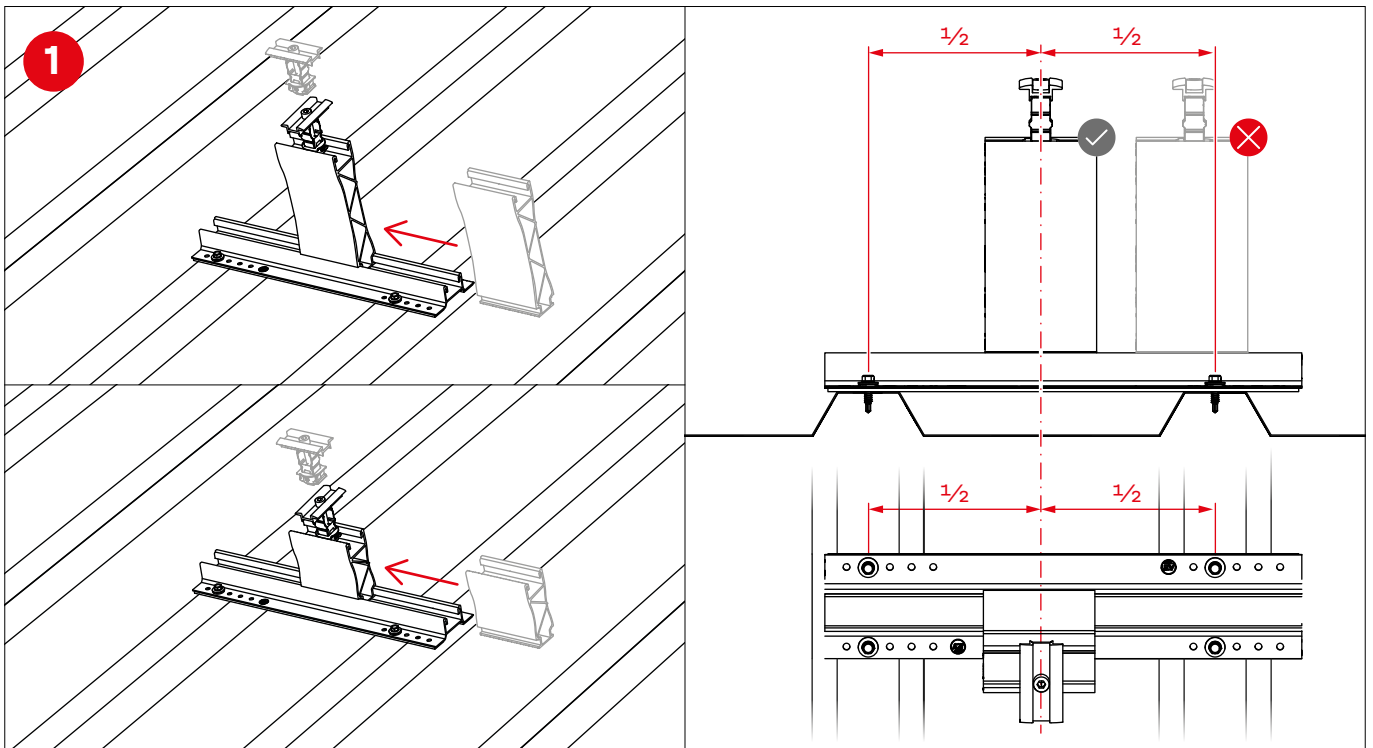

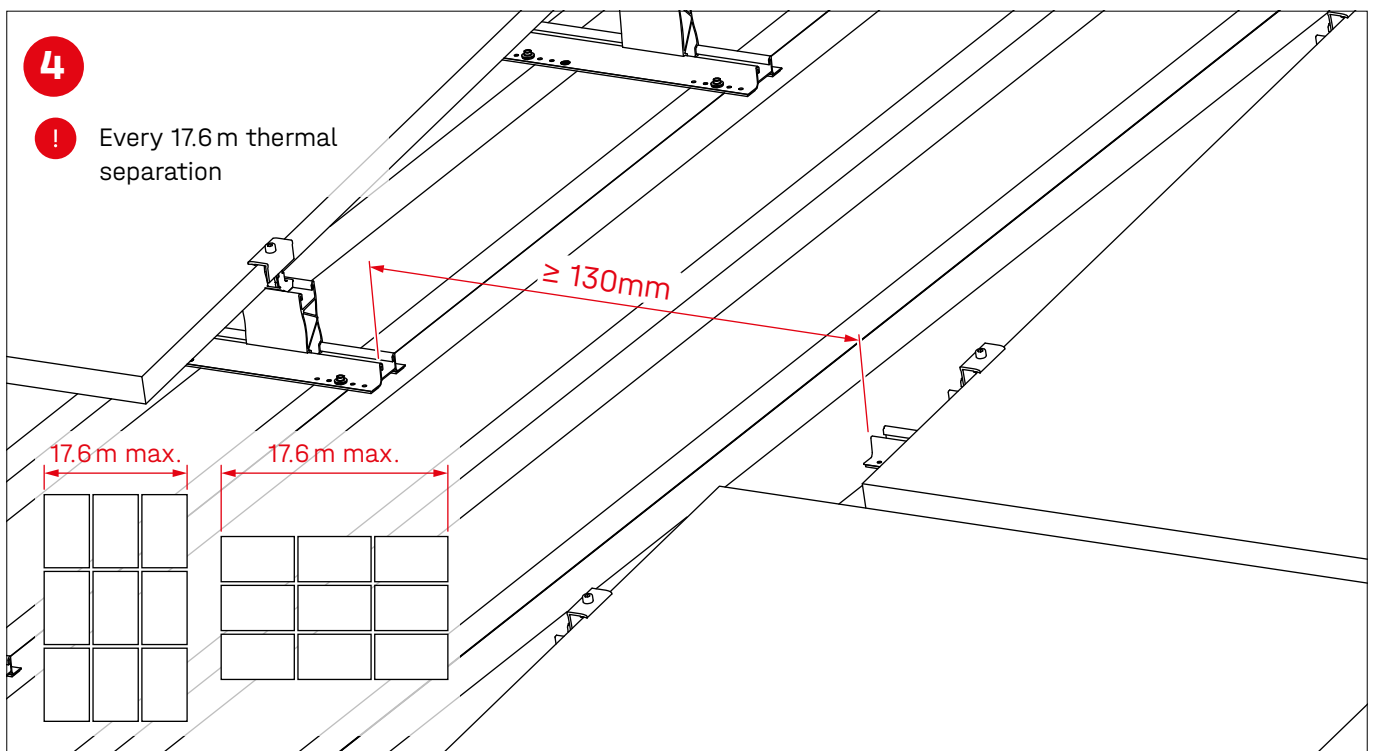
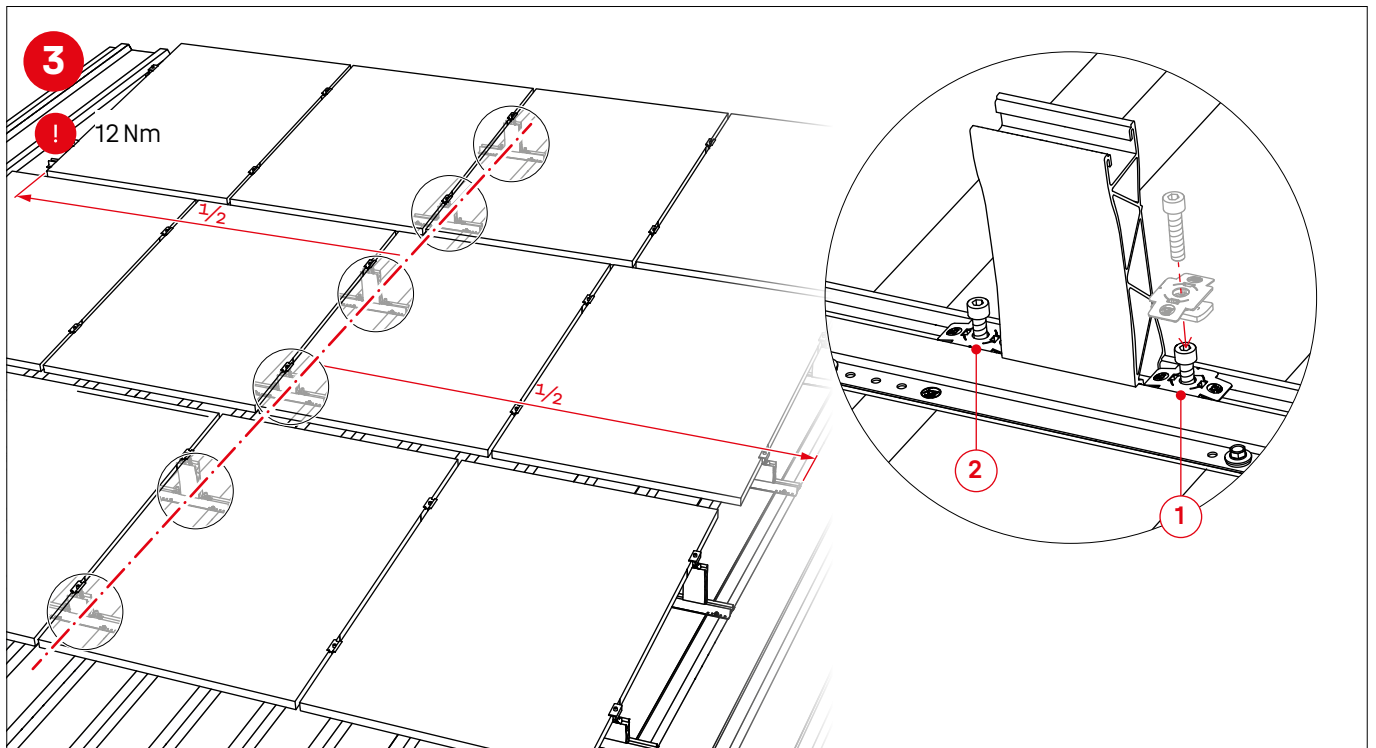

## Roof-parallel elevation with RailUp

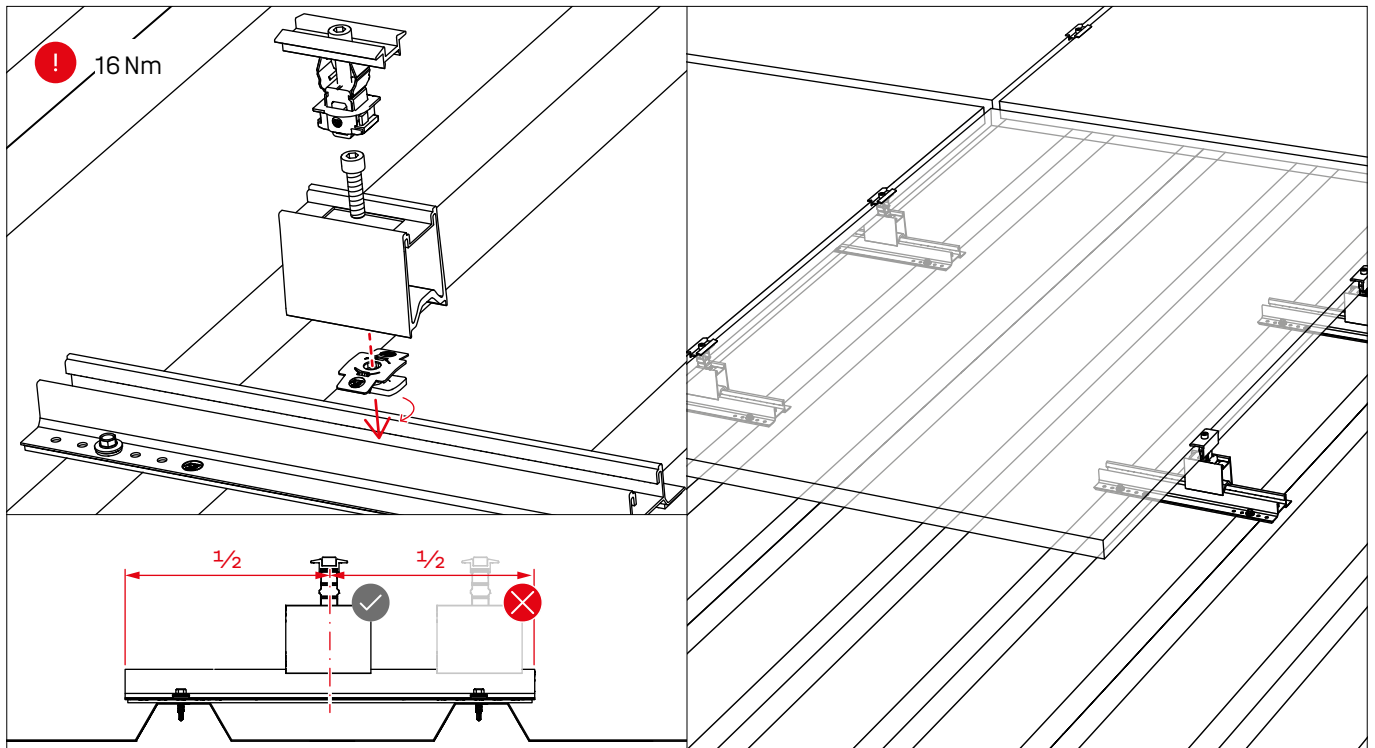

# Module frame earthing with TerraGrif

## TerraGrif QL or K2SZ

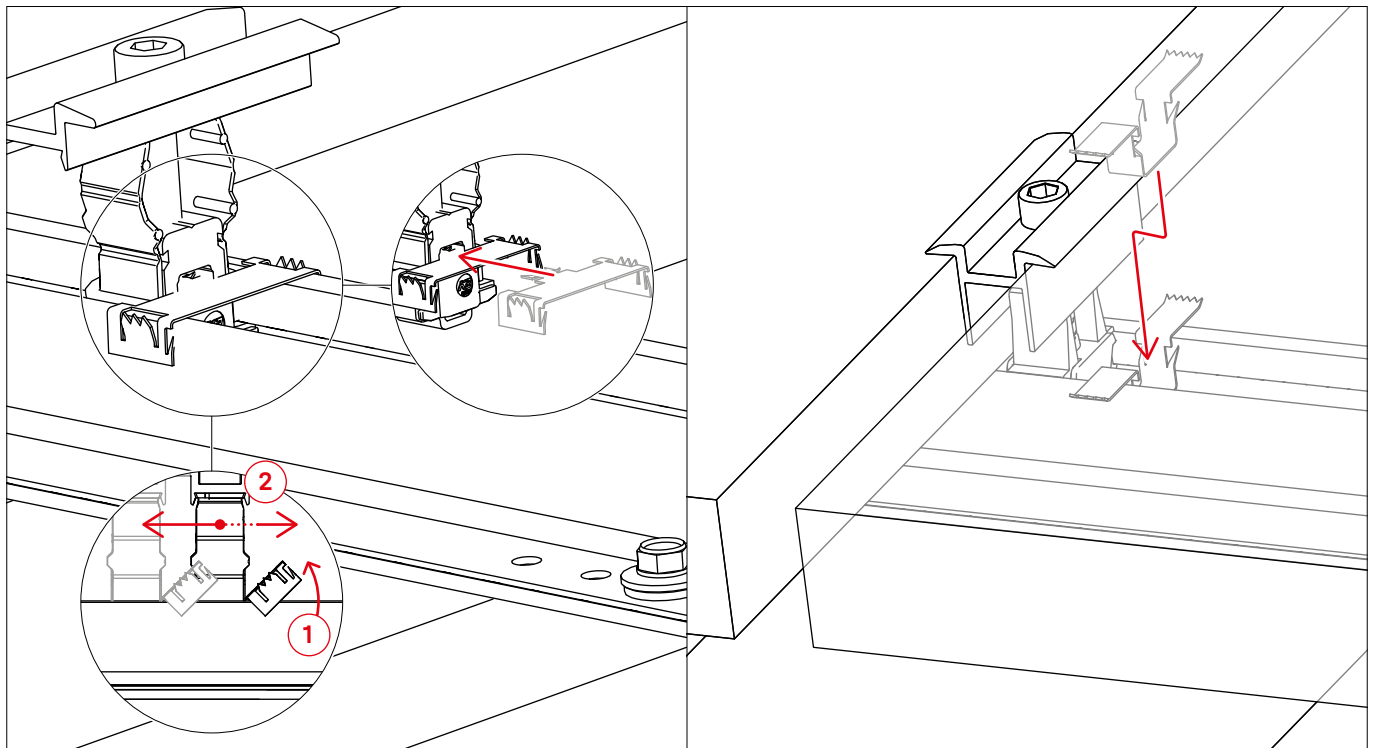

## TerraGrif PL for MiniFive Front/End

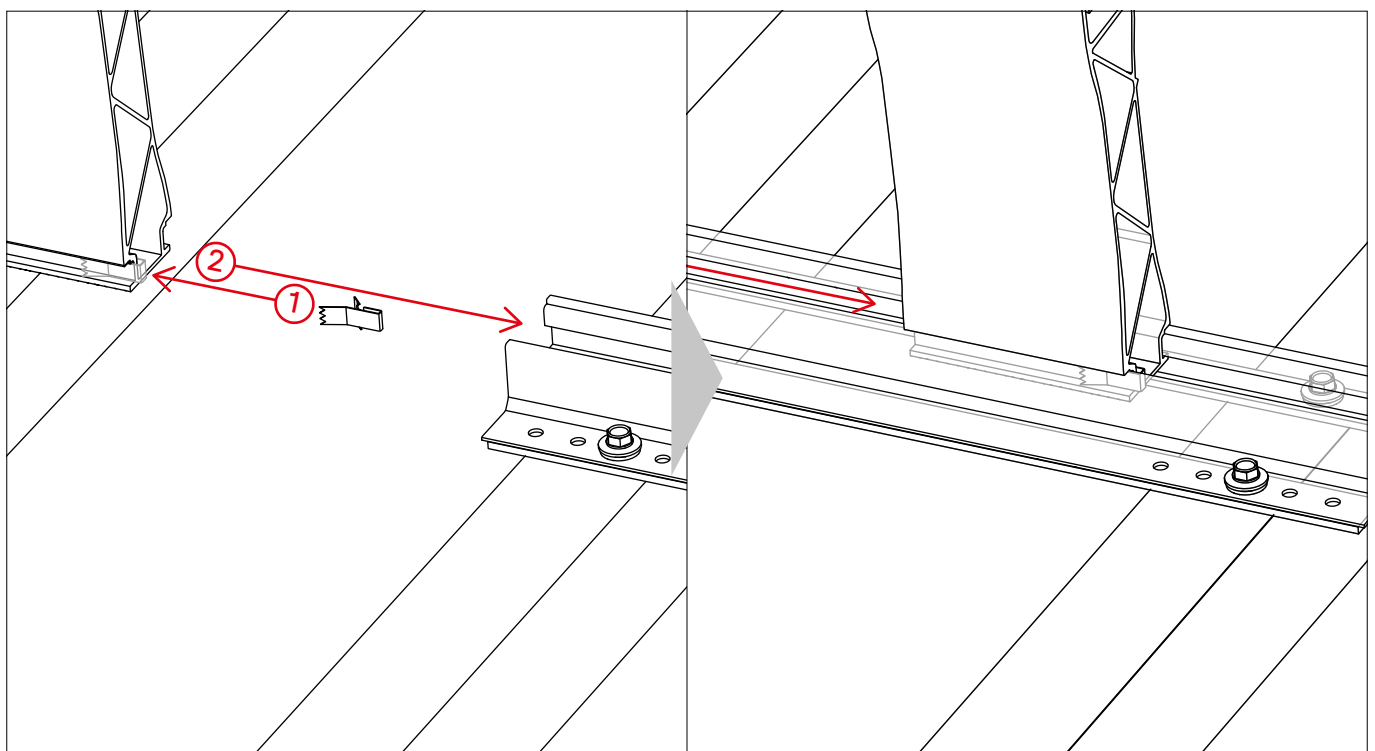



# Notes

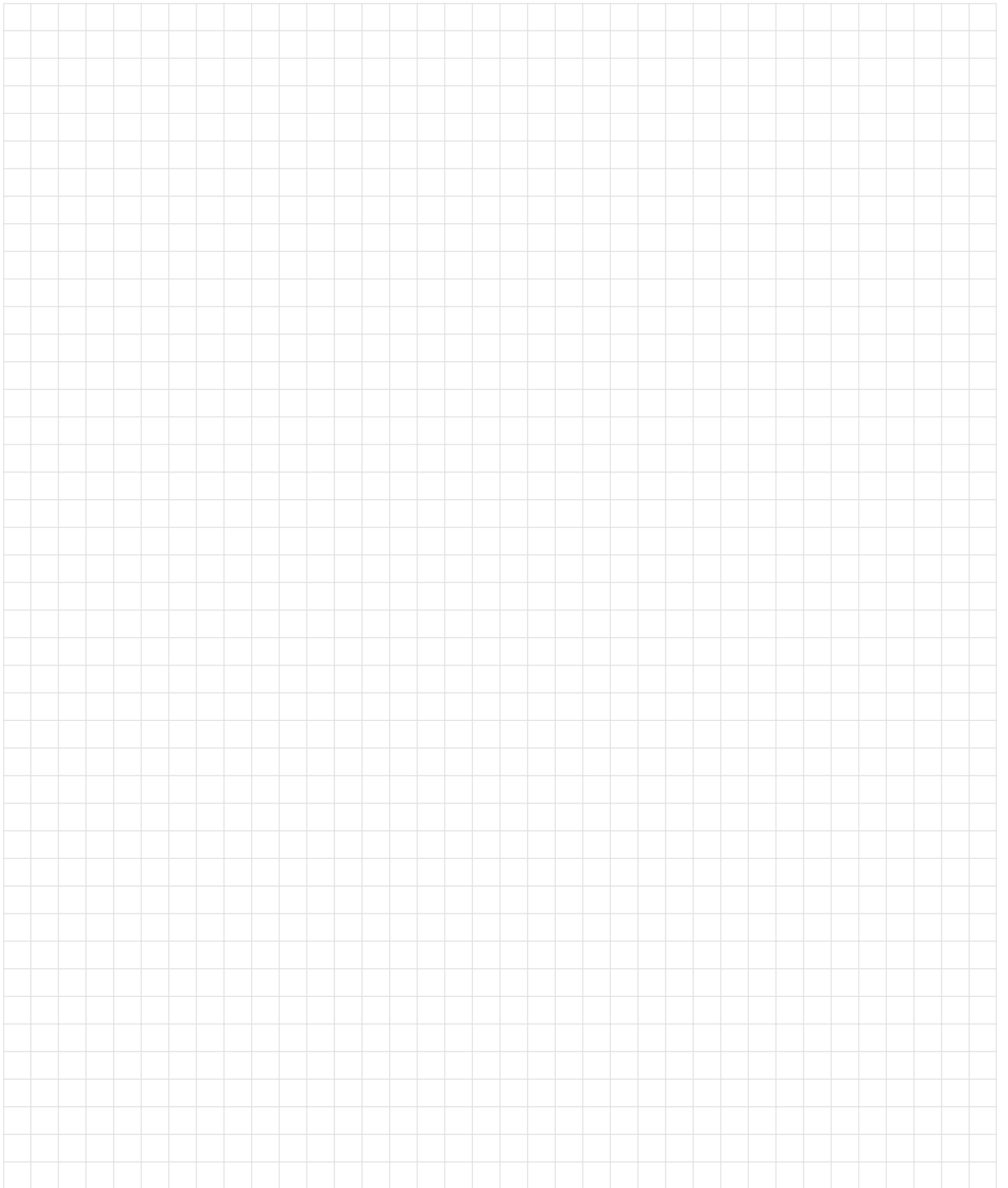

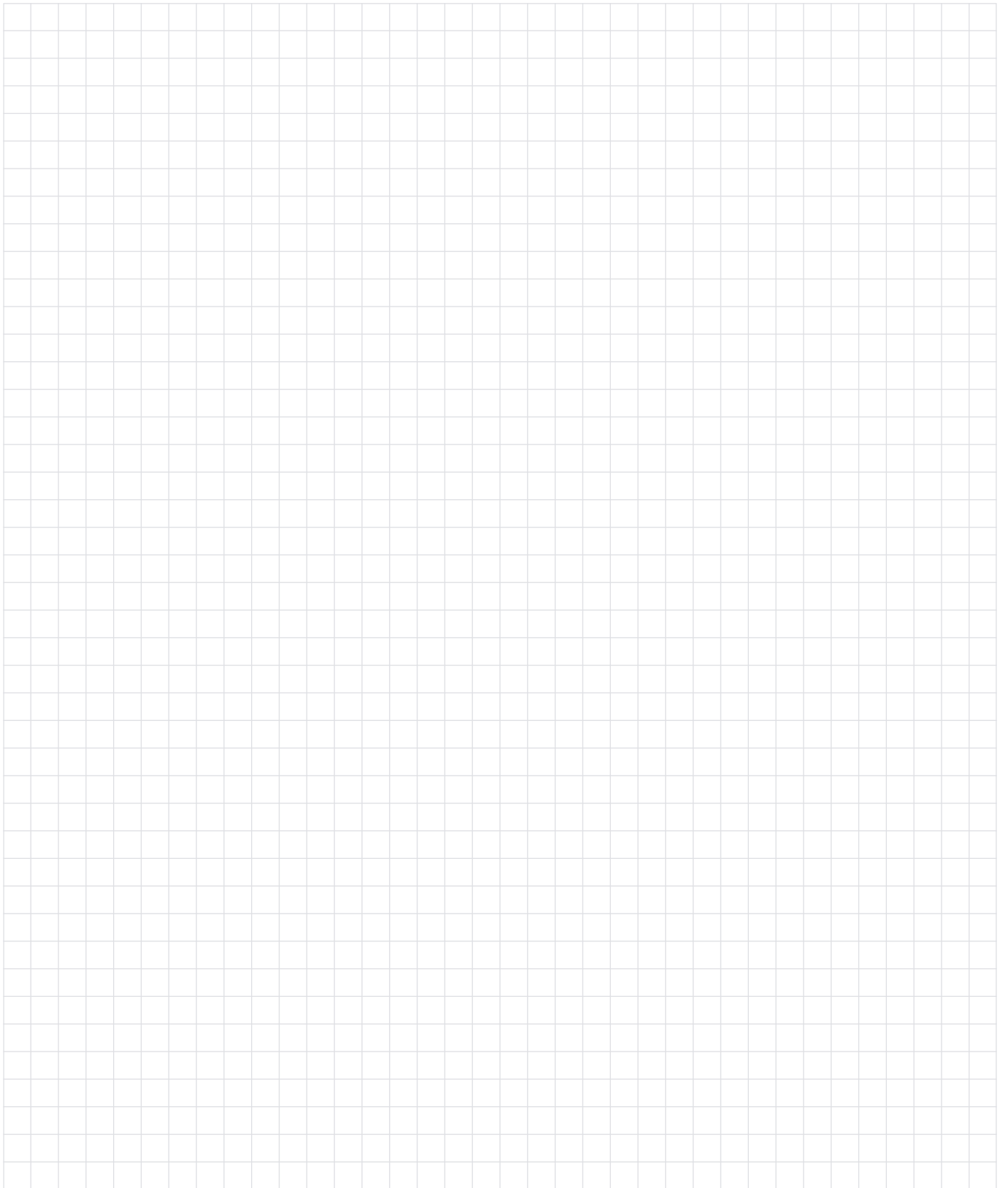

## Thank you for choosing a K2 mounting system.

Systems from K2 Systems are quick and easy to install. We hope these instructions have helped. Please contact us with any questions or suggestions for improvement. Our contact data:

- [k2-systems.com/en/contact](https://k2-systems.com/en/contact)
- **Service Hotline: +49 7159 42059-0**

Our General Terms of Business apply. Please refer: [k2-systems.com](https://k2-systems.com)

### K2 Systems GmbH

Industriestraße 18 · 71272 Renningen · Germany  
+49 (0) 7159 - 42059 - 0 · [info@k2-systems.com](mailto:info@k2-systems.com) · [k2-systems.com](https://k2-systems.com)

MiniRail MK2 Assembly EN V16 | 0922 · Subject to change · Product illustrations are exemplary and may differ from the original.



**Connecting Strength**

**[k2-systems.com](https://k2-systems.com)**