

## Appendix B – Manufacturer’s CLS Product Information

This form is available in a Microsoft Word version from the ENA’s website.

### **G100/2 - Form B - Compliance Verification Report for Customer Export or Import Limitation Schemes**

This form shall be used by the Manufacturer to demonstrate and declare compliance with the requirements of EREC G100. The form can be used in a variety of ways as detailed below:

1. For Fully Type Tested status

The Manufacturer can use this form to obtain Fully Type Tested status for a CLS by registering this completed form with the Energy Networks Association (ENA) Type Test Register.

2. To obtain Type Tested status for a product

The Manufacturer can use this form to obtain Type Tested status for one or more Components which are used in a CLS by registering this form with the relevant parts completed with the Energy Networks Association (ENA) Type Test Register.

3. One-off Installation

The Installer can use this form to confirm that the CLS has been tested to satisfy the requirements of this EREC G100. This form shall be submitted to the DNO before commissioning.

A combination of (2) and (3) can be used as required, together with Form C where compliance of the CLS is to be demonstrated on site.

Note:

If the CLS is Fully Type Tested and registered with the Energy Networks Association (ENA) Type Test Register, Form C shall include the Manufacturer’s reference number (the Type Test Register system reference), and this form does not need to be submitted.

Where the CLS is not registered with the ENA Type Test Register or is not Fully Type Tested this form (all or in parts as applicable) shall be completed and provided to the DNO, to confirm that the CLS has been tested to satisfy all or part of the requirements of this EREC G100.

<b>CLS Designation</b>			
<b>Manufacturer name</b>		Huawei Technologies Co.,Ltd.	
Address		Administration Building, Headquarters of Huawei Technologies Co., Ltd., Bantian, Longgang District, Shenzhen, 518129, P.R.C	
Tel		Web site	
E:mail			
<b>Installer’s name</b>			
Address			
Tel		Web site	
E:mail			

Export/Import capabilities			
Export	Y	Import	Y
Description of Operation			
<p>EREC G100 section 4.2 requires a description of the CLS, and schematic diagram, to be provided to the Customer. Please provide that description and the diagram here. <b>Error! Reference source not found.</b></p>			
<p>Huawei C&amp;I PV and ESS solution includes 2 scenarios:</p> <p>Scenario 1—Single inverter System: The inverter is able to communicate with the smart meter at the grid-tied point in real time and control itself to meet the requirements of EREC G100 version 2 policy requirements. (In this system, the Smart Dongle is not a CLS device and used only for Internet connection )</p> <p>Scenario 2—Smartlogger System: Only applied to non-domestic installations. Smartlogger is used as the control subject of the CLS. The system may includes multi inverters and/or ESSs. Real-time communication and control between the SmartLogger and smart meters, inverters, and ESSs meet EREC G100 version 2 policy requirements.</p>			
<p><b>Single Inverter System</b></p> <p>The diagram illustrates the Single Inverter System. It features a PV module connected to an Inverter. The Inverter is connected to a Load and a Smart meter. The Smart meter is connected to the Power grid. A Smart Dongle is connected to the Inverter and provides 4G/WIFI/FE communication to Fusion solar. The Inverter and Smart meter are connected via RS485 communication.</p>			
<p><b>Smartlogger System</b></p>			

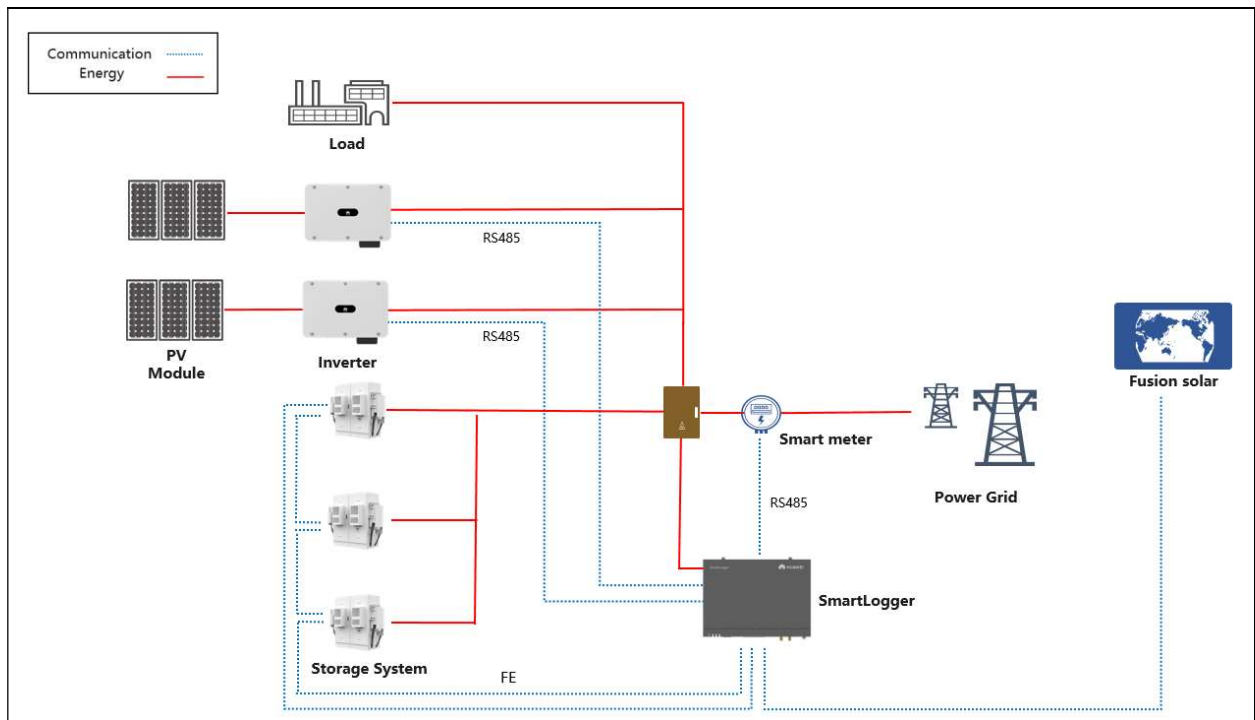

PV modules convert sunlight into DC, and inverters convert DC into AC for loads or directly to the power grid. The smart meter can obtain the inlet and outlet currents of the grid-tied point. The inverter(Scenario 1) or Smartlogger(Scenario 2) controls the energy inlet and outlet of the grid-tied point based on the data fed back by the meter. so as not to exceed the MEL.

Users can obtain data through the Fusion Solar web page and mobile app.

### How to set and control:

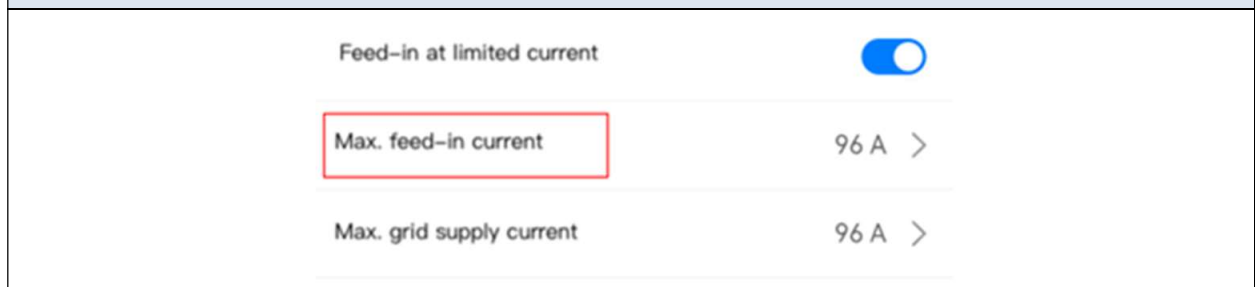

Enable the Feed-in at limited current in fusion solar app, you can set value to MAX. feed-in current , MAX. grid supply current. When the current exceeds the preset values, the inverter will adjust the current once in each adjustment interval. Ensure that the current is within the set value.

### Communications Media

Document the provisions made for the use of various communication media, and both the inherent characteristics and the design steps made to ensure security and reliability.

### Single Inverter System



Name	Type	Function	Information
------	------	----------	-------------

Inverter	Inverter: SUN2000-30/36/40K-M3 SUN2000-100/115K-M2	Convert DC to AC; Controls the energy input and output of the grid-tied point;	Huawei device
Dongle	communication module: SDongleA-05(AP+STA) SDongleB-06	Communication between the SUN2000 and HUAWEI CLOUD	Huawei device
Router	Router	Internet available	Third-party device
Fusion solar	Huawei Cloud	Server	Huawei server
Fusion solar App	Huawei App	user interface	Huawei App
Meter	Huawei Smart Power Sensor: DTSU666-H YDS60-C24 DTSU666-HW YDS60-80	Measure the electrical parameters of the grid-tied point for system control.	Huawei device

### Smartlogger System

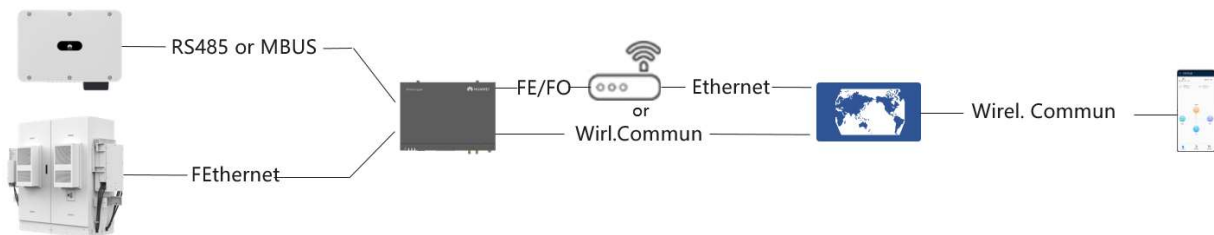

Name	Type	Function	Information
Inverter	Inverter SUN2000-30/36/40K-M3 SUN2000-100/115K-M2	Convert DC to AC; Controls the energy input and output of the grid-tied point;	Huawei device
ESS	Energy storage system PCS:LUNA2000-100KTL-M1 ESS:LUNA2000-97/129/161/200KWH-2H1	PCS : a bidirectional converter  ESS: capable of storing energy to supply power at a later time	Huawei device

Smartlogger	Communication control module SmartLogger3000A	Connects inverter, ESS to the Internet  Controls the energy input and output of the grid-tied point;	Huawei device
Router	Router	Internet available	Third-party device
Fusion solar	Huawei Cloud	Server	Huawei server
Fusion solar App	Huawei App	user interface	Huawei App
Meter	Huawei Smart Power Sensor	Measure the electrical parameters of the grid-tied point for system control.	Huawei device

### Cyber Security

Confirm that the Manufacturer or Installer of the CLS has provided a statement describing how the CLS has been designed to comply with cyber security requirements, as detailed in section 4.7.**Error! Reference source not found.**

Huawei's cyber security assessment is based on the ETSI EN 303645 standard.

We Huawei Technologies Co.,Ltd., declare that G100 certified products,

And the variant models to be included in the certification,

Are in compliance with Cyber security requirements in accordance with the standards:

- ETSI EN 303 645

### Power Quality Requirements

Where the CLS includes the power electronics that controls generation or loads (as opposed to the power electronics being included in Devices that are subject to their own power quality compliance requirements) please submit the harmonic and disturbance information here as required by EREC G5 and EREC P28.

Not applicable to our system as it is not a stand-alone device, and it works as a system.

### Fail Safe

**CLS internal failure: please submit here the description of the internal Fail Safe design and operation. Please also document how it has been demonstrated, including the non-volatile recording of times and numbers of state 2 operations, and confirm the overall response of the CLS to this internal failure.**

### Single Inverter System

The meter communicates with the inverter through the Modbus protocol. If a communication fault (including meter faults) occurs between the meter and the inverter, the inverter can detect the fault in real time and report the fault code. In addition, the CLS forcibly enters state 3 and shuts down the power output to ensure that the current at the grid-tied point does not exceed the MEL. If the inverter fails to

adjust the MEL and the grid-tied current exceeds the MEL, the inverter records the event and saves it in the memory. The event will not be lost even if the power is off. Once the fault is rectified, the CLS will automatically recover.

### Smartlogger System

The same communication failure protection mechanism occurs between the meter and SmartLogger including meter and Smartlogger fault, which causes fail safe operation of the whole CLS to ensure the feed-in current do not exceed MEL. In addition, communication failure occurring on several inverters/PCSs will lead to state 3 operation of these faulty inverters/PCSs, and effective operation of others. Non-volatile recording in Smartlogger guarantee automatic recovery of CLS, which implementation method is the same as that of Single Inverter System.

Communication and power supply failures between Components and Devices. Please document here compliance with EREC G100 section 5.5. **Error! Reference source not found.**

Component/Device number/description	Communication failure test	Power supply failure test
Single Inverter System		
Meter DTSU666-H YDS60-C24 DTSU666-HW YDS60-80	PASS	PASS
Inverter SUN2000-30/36/40K-M3 SUN2000-100/115K-M2	PASS	PASS
SmartLogger System		
The smart meter DTSU666-H YDS60-C24 DTSU666-HW YDS60-80	PASS	PASS
Smarterlogger Smartlogger3000A	PASS	PASS
Inverter SUN2000-30/36/40K-M3	PASS	PASS

SUN2000-100/115K-M2		
PCS	PASS	PASS
LUNA2000-100KTL-M1		

### Operational Tests

In accordance with EREC G100 section 5.6 undertake the tests A to D to confirm correct operation in state 1 and state 2, that transition into state 3 occurs as required, and that behaviour in state 3 is also as required. **Error! Reference source not found.**

#### Test A

Nominal Export Limit (for type tests this will be at maximum, minimum and one intermediate setting) in Amp:	100A
---	------

Nominal Import Limit (for type tests this will be at maximum, minimum and one intermediate setting) in Amp:	100A
---	------

No	Starting level	Step value	CLS registers change in level?	CLS and/or Component and/or Device initiates correct response of $\geq 5\%$ ?	Duration of step in test	Correct state 1/state 2 operation
1	98 A	105 A	Yes	Yes	58s	1 > 2 > 1
2	98A	109A	Yes	Yes	58s	1 > 2 > 1
3	98A	119A	Yes	Yes	58s	1 > 2 > 1
4	98A	105A	Yes	Yes	58s	1 > 2 > 1
5	98A	112A	Yes	Yes	58s	1 > 2 > 1
6	98A	121A	Yes	Yes	58s	1 > 2 > 1

#### Test B

Nominal Export Limit:	15A
-----------------------	-----

Nominal Import Limit	15A
----------------------	-----

No	Starting level	Step value	CLS registers change in level?	CLS and/or Component and/or Device initiates correct response of $\geq 5\%$ ?	Duration of step in test	Correct state 3 operation
----	----------------	------------	--------------------------------	---	--------------------------	---------------------------

7	13A	194A	Yes	Yes	62s	1 > 2 > 3
8	--	--	--	--	--	--

### State 3 Reset

These tests are to demonstrate compliance with section EREC G100 4.5.2. **Error! Reference source not found.**

Please document how the reset from state 3 to state 1 has been demonstrated. Please include how the reset is achieved.

Please confirm that for CLSs to be installed in Domestic installations three (3) resets causes lockout or that for non-domestic installations lockout can only be reset after four hours. Please explain how lockout is reset.

#### Single Inverter System

1. After entering state 3, the system generates an alarm indicating that the power control of the grid-tied point is abnormal and the inverter enters the locked state.
2. Users or installers troubleshoot the system.
3. The installers performs reset settings through the app, and starts unlocking and enters state 1. At this time, the system displays Grid Connected Running, indicating that the system has returned to normal operation mode state 1.
4. If three resets occur, the system will remain locked until 30 days later.

In term of the rated output current of the inveter larger than 100A, which means that the inverter should be used in non-domestic installations, the inverter can only be reset after 4hours.

#### SmartLogger System

1. After entering state 3, the system generates an alarm indicating that the power control of the grid-tied point is abnormal and the inverters and/or ESSs enters the locked state.
2. Users or installers troubleshoot the system.
3. The installers performs reset settings through the app, and starts unlocking and enters state 1. At this time, the system displays Normal, indicating that the system has returned to normal operation mode state 1.
4. SmartLogger System only applied to non-domestic installations, lockout can only be reset after four hours.