

ASSEMBLY INSTRUCTIONS

**Solarfasteners
SolidRail System**



Content

▶ Tools overview	3
▶ General safety information	4
▶ Required Materials	5
▶ Assembly	6
▶ Notes	8

Quality tested – several certifications

K2 Systems stands for secure connections, highest quality and precision. Our customers and business partners have known that for a long time. Independent institutes have tested, confirmed and certified our capabilities and components.

Please find our quality and product certificates under:

www.k2-systems.com/en/technical-information



Tools overview



5 mm



6 mm



6-30 Nm
(4,5-22,2 lb-ft)



6 mm

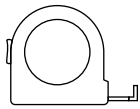

≥3,0m



≥6,0m

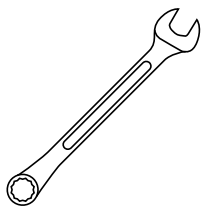

15 mm

General safety information

Please note that our general mounting instructions must be followed at all times and can be viewed online at www.k2-systems.com/en/technical-information.

- ▶ The equipment may only be installed and operated by qualified and adequately trained installers.
- ▶ Prior to installation, ensure that the product complies with on-site static loading requirements. For roof-mounted systems, the roof load-bearing capacity must always be checked.
- ▶ National and local building regulations and environmental requirements must be adhered to.
- ▶ Compliance with health and safety regulations, accident prevention guidelines and applicable standards is required.
 - Protective equipment such as safety helmet, boots and gloves must be worn.
 - Roofing works must be in accordance with roofing regulations utilising fall protection safeguards when eaves height exceeds 3 m.
 - At least two people must be present for the duration of the installation work in order to provide rapid assistance in the event of an emergency.
- ▶ K2 mounting systems are continuously developed and improved and the installation process may thereby change at any time. Prior to installation consult our website at www.k2-systems.com/en/technical-information for up-to-date instructions. We can send you the latest version on request.
- ▶ The assembly instructions of the module manufacturer must be adhered to.
- ▶ Equipotential bonding/grounding/earthing between individual parts is to be performed according to country specific standards, as well as national laws and regulations.
- ▶ At least one copy of the assembly instructions should be available on site throughout the duration of the installation.
- ▶ Failure to adhere to our general safety and assembly instructions and not using all system components, K2 is not liable for any resulting defects or damages. We do not accept liability for any damage resulting in the use of competitor's parts. Warranty is excluded in such cases.
- ▶ German law shall apply excluding the UN Convention on CISG. Place of venue is Stuttgart. Our General Terms of Business apply.
- ▶ If all safety instructions are adhered to and the system is correctly installed, there is a product warranty entitlement of 12 years! We strongly recommend reviewing our terms of guarantee, which can be viewed at www.k2-systems.com/en/technical-information
We will also send this information on request.
- ▶ Dismantling of the system is performed in reverse order to the assembly.
- ▶ K2 stainless steel components are available in different corrosion resistance classes. Each structure or component must be carefully checked for possible corrosion exposure.

The following guidelines apply



The Solarfastener SolidRail system can be used without further testing by K2 systems in the following standard conditions. To calculate maximum distances between supports we recommend using our calculation tool K2Base. The system is also suitable for higher requirements. However, if a value exceeds the standard conditions, please contact K2 Systems.



Roof requirements

- Roof pitch of 5-75°



Structural requirements

- The static verification of components is automatically calculated for each location using our Base On planning software
- The sufficient holding force of the roof covering at the support or substructure must be ensured on site.



Important mounting instructions

- We recommend a thermal separation after maximum of 18.30 m.
- Do not use Middle and End Clamp set at rail joints. Distance to rail joint min. 20 mm.
- Minimum spacing of 50 mm from module edge to rail end.
- Tightening torque for all module clamps 14 Nm
- For manufacturer information regarding clamps see the manufacturing module data sheet.
- A module row spacing according to planning specification K2 System must be observed.
- The earthing must be provided by the customer and must be carried out according to the respective country-specific regulations.
- The solar fasteners are suitable for fastening on steel/aluminium and fibre-cement profiles.
- On-site general standards and regulations for lightning protection must be observed and consultation with a specialist to create a lightning protection concept is recommended (use lightning protection clamp if necessary).

Essential: The materials required

All system components listed in the following are essential for assembling the K2 Systems SolidRail system. The piece quantities are calculated on the basis of the respective requirements. The listed item numbers facilitate the comparison of items.



Solar fasteners with sealing shim for steel

| Article number system-specific

No adapter plate; Material: stainless steel, FZD

Alternative: Solar fasteners for wood on request

Solar fasteners with calotte for steel

| Article number system-specific

No adapter plate; Material: stainless steel, aluminium, EPDM

Alternative: Solar fasteners for wood on request

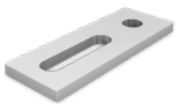

Aluminium adapter plate

| Article number system-specific

Material: aluminium



K2 Bridge

| Article number system-specific

Material: aluminium

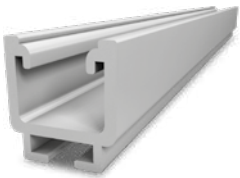

MountingRail K2 SolidRail

| Article number system-specific

UltraLight, Light, Medium or Alpin
Material: aluminium

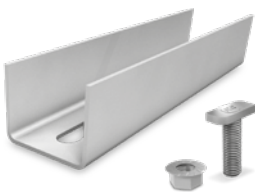

K2 SolidRail Connector Set

| Article number system-specific

The set consists of:

- ▶ 1 SolidRail Connector, aluminium EN AW-6063 T66
- ▶ 2 T-Bolts M10x30 (1000041), stainless steel A2
- ▶ 2 Locking nuts M10 (1000042), stainless steel A2



K2 EndCap SolidRail

| Article number system-specific

Material: glass fibre reinforced polyamid



T-Bolt M10x25

| 1000571

Material: Stainless steel; Head 28/15

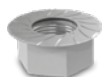

K2 Hexagon flange nut with serration M10

| 1000042

Material: Stainless steel, drive: 15 mm

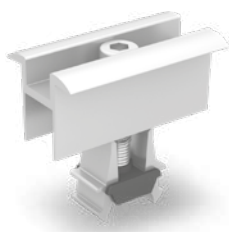

K2 Universal-Module middle clamp OneMid

| 2002515

Module frame height: 32-42 mm

Alternative: K2 Module middle clamp XS Set

| Article number system-specific



K2 Universal-Module end clamp OneEnd

| 2002514

Module frame height: 32-42 mm

Alternative: K2 Module end clamp Set

| Article number system-specific

Additional material for cross bracing (SolidRail)



MountingRail K2 SolidRail

UltraLight, Light, Medium or Alpin
Material: aluminium

| Article number system-specific



K2 Set Angle bracket

| 2001732

The set consists of:

- ▶ 1 angle bracket, stainless steel
- ▶ 1 T-bolt M10, stainless steel
- ▶ 1 locking nut M10, stainless steel
- ▶ 1 Bolt with serrated under head M8, stainless steel
- ▶ 1 M K2 slot nut M8, stainless steel

Additional material for cross bracing (SingleRail)

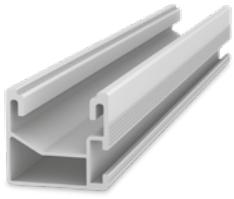

Mountingrail K2 SingleRail

Material: aluminium EN AW-6063 T66

| Article number system-specific

Alternative: Mountingrail K2 CrossRail
Material: aluminium EN AW-6063 T66

| Article number system-specific

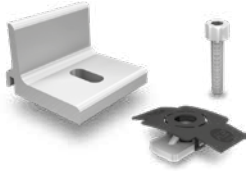

K2 Climber 36/48 Set

The set consisting of:

- ▶ 1 Climber 36/48 (1002286), aluminium EN AW-6063 T66
- ▶ 1 bolt with serrated under head M8x20, stainless steel A2
- ▶ 1 MK2 insert nut M8 (1001643), stainless steel and PA

| 1006041



K2 SingleRail Connector Set

The set consisting of:

- ▶ 1 SingleRail connector, aluminium EN AW-6063 T66
- ▶ 4 T-Bolts M8x20 (1002387), stainless steel A2
- ▶ 4 Locking nuts M8 (1000043), stainless steel A2

| Article number system-specific

Description Solar fasteners

The Solar fasteners are available for different types of sub-structure materials (steel or wood).

The Solar fasteners have different threads in the sealing screw. The tightness of the roof covering is created through the use of calottes when fastening on steel / aluminium profiles and FZD seals on fiber cement profiles.

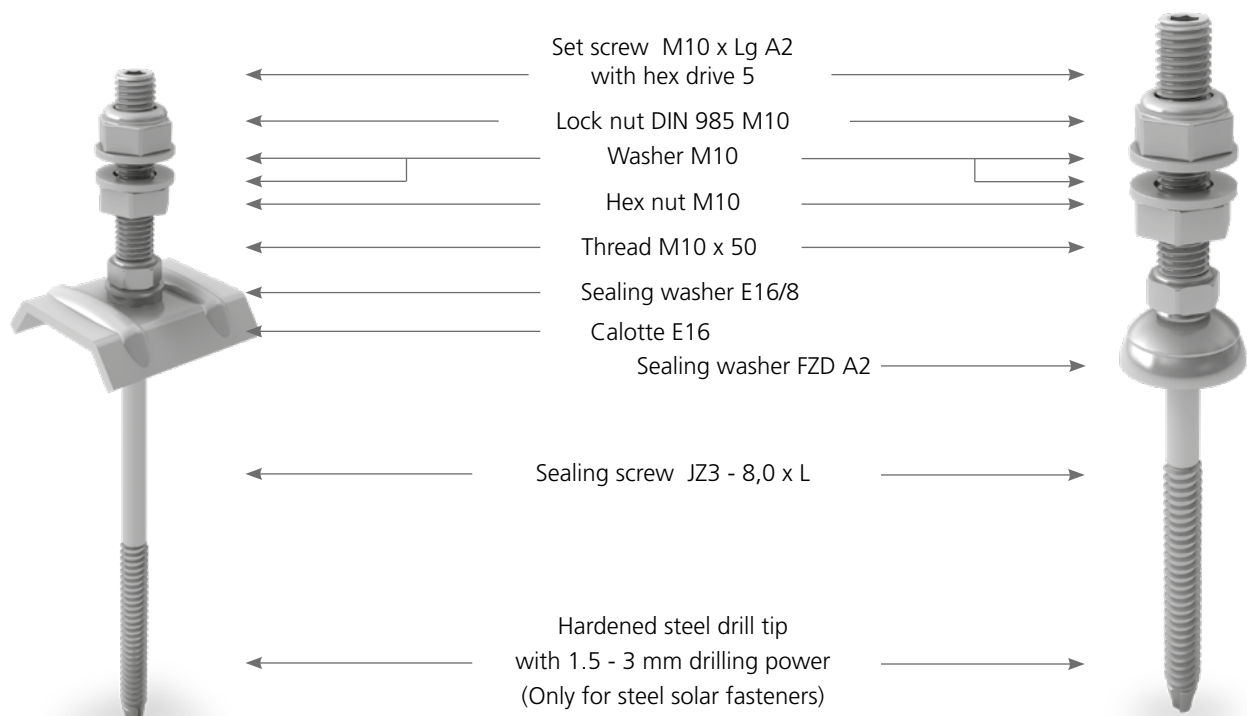

1a Pre-drilled hole steel/aluminium profile on steel substructure

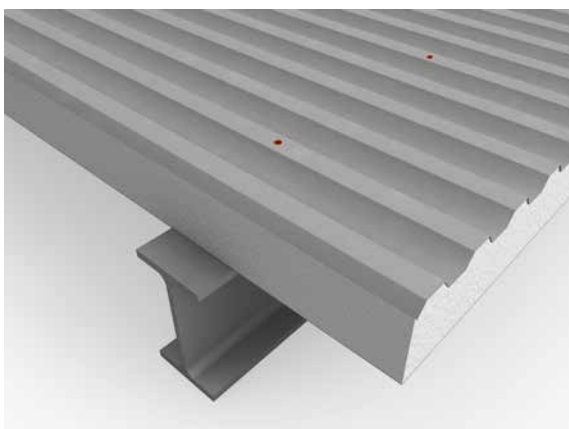

Measure the screw distances according to statics or K2 Base. Check position of purlins and pre-drill through the profile sheets into the purlins.

Attention:

With a thickness of the steel substructure of up to 3 mm no pre-drilling is necessary! The solar fastener can be drilled, tapped and screwed in one operation using the hardened steel drill tip.

Metal profiles:

The pre-drilled hole diameter in the metal profiled sheet = the pre-drilled hole diameter in the substructure

1b Pre-drilled hole fibre cement profile on wood substrate

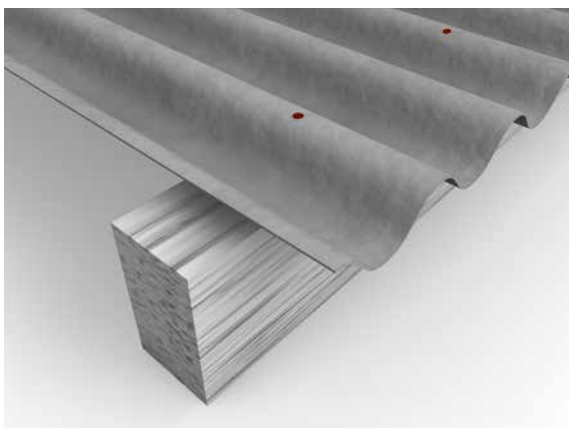

Measure the screw distances according to statics or K2 Base. Check position of purlins and pre-drill through the fibre cement profiles into the purlins.

Fibre cement profiles:

The pre-drilled hole diameter in the fibre cement profiles must always be greater than the diameter of the solar fasteners.

Table for drilling diameters

Material substructure		Steel				Wood	
Material thickness in mm	1,5 < 3,0	3,0 < 5,0	5,0 < 7,5	7,5 < 10	≥ 10		
	Pre-drilled hole diameter in mm for metal profile sheets + substructure						
Solar fasteners for steel Ø 8 mm	without pre-drilling	6,8 mm	7 mm	7,2 mm	7,4 mm		
Solar fasteners for wood Ø 8 mm						5,5 mm	5,5 mm
	Pre-drilled hole in mm for fibre cement profiles						
Solar fasteners for wood Ø 8 mm	In profile sheet					11 mm	11 mm
	In wood substrate					5,5 mm	5,5 mm

Assembly

2a Clean surface, lay calottes

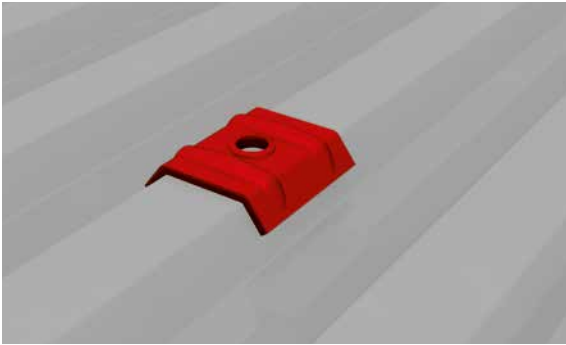

Before mounting the solar fasteners, remove any burr from the surface of the profile sheets.

In the case of solar fasteners for metal profile sheets, lay calotte over the drilled holes. (For solar fasteners for fibre cement profiles the seal is pre-assembled on the solar fastener)

Materials required for metal profile sheet: calotte

3a Screw solar fastener (Metal profiles)

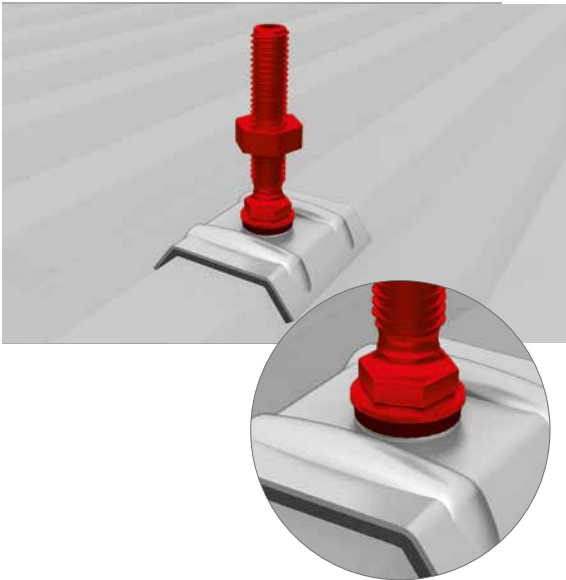

Insert the solar fastener into the pre-drilled hole through the calotte and screw in.

Additional information: Do not tighten the solar fastener with the torque, the seal must be slightly compressed and rest on the entire surface.

Materials required: Solar fastener

3b Screw Solar fastener (Fibre cement profile)



Additional information:

Do not tighten the solar fastener with the torque, the seal must be slightly compressed and rest on the entire surface.

Materials required: Solar fastener



WRONG



CORRECT



WRONG

From this step the assembly is identical for the different roofing types

4 Adjust hex nut



Adjust nut in height according to direction of the module carrier rails.

Materials required: Hex nut, washer

5 Mount adapter plate

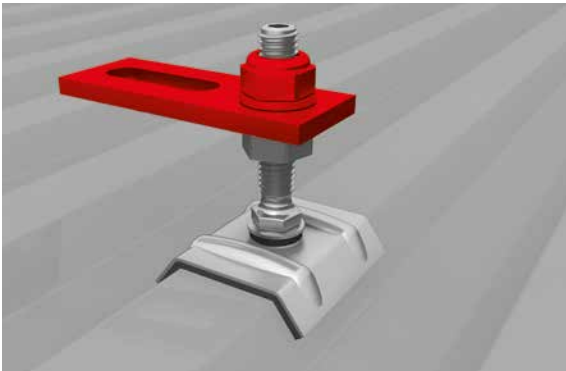

Place adapter plate, adjust and mount additional washer with locking nut.

The height of the adapter plate is determined by the two nuts. Secure solar fastener against turning with hex wrench. After correct setting of both nuts, lock and tighten.

Materials required: Adapter plate, washer, and self-locking nut

Assembly

6 Mounting rails and rail connectors

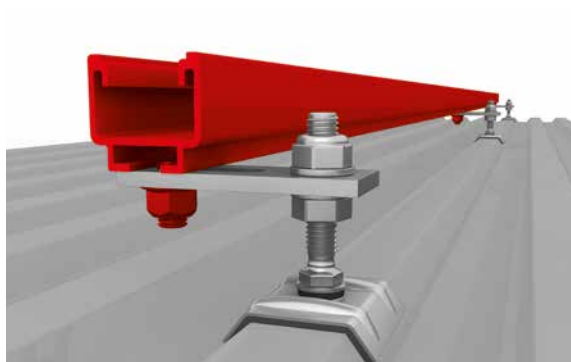

Ensure correct position of T-bolt. After inserting into the lower chamber of the rail, the T-bolt is turned 90 degrees counterclockwise. Lock the projected K2 module carrier rail Solid on the adapter plate with an M10 T-bolt and tighten.

Tightening torque: 32 Nm

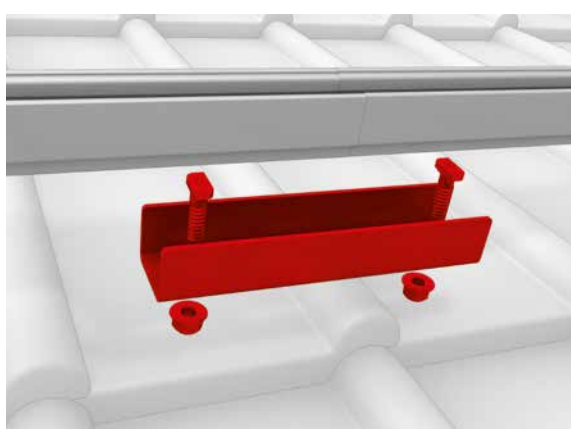

Lay Mounting Rail on joint with rail connector and connect with T bolts and self-locking nuts. The rail joint may not be in the range of the roof fastener.

Tightening torque 35 Nm.

Materials required: K2 mounting rail Solid, T-Bolt M10x30, M10 self-locking nut, rail connector set

7 Mounting End Clamps

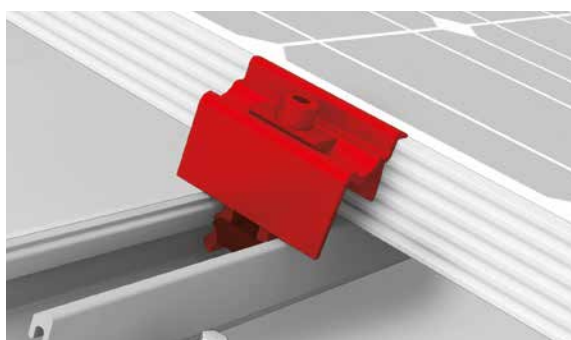

Fix the module in place at the end of a row with universal module end clamp OneEnd. Click the Stance in the notches. Alternatively use the standard end clamp. Insert the MK2 nut into the mounting rail and turn clockwise by 90°. Place clamps on the module frames and fix them. Never mount module end clamps directly on the rail joint or end of the rail! (Spacing: min. 50 mm from edge of module frame). Pay attention to the mounting instructions by module manufacturer!

Tightening torque 14 Nm.

Materials required: OneEnd

8 Attach module gaps



Use two universal module middle clamp OneMid between two modules. Click the Stance in the notches. Place clamps on the module frames and fix them. Tightening torque 14 Nm.

Materials required: OneMid

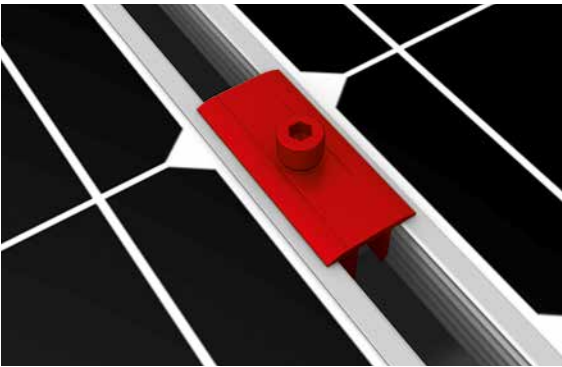

Attaching with XS Middle Clamp

Use two XS Middle Clamps between two modules, which must also be screwed with the DIN 912 M8 screws in the slot nuts.

Tightening torque 14 Nm.

Materials required: Module middle clamp XS Set

Alternative system assembly with K2 Bridge

1 Mount K2 Bridge

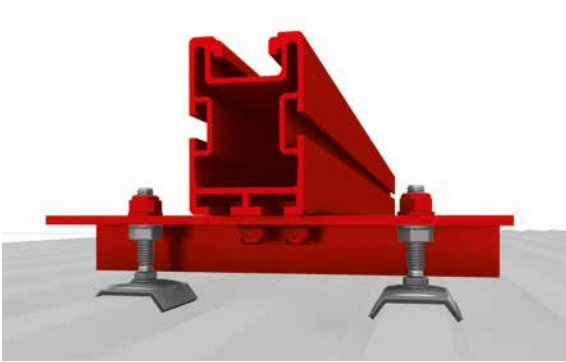

The K2 Bridge is mounted on two solar fasteners instead of the adapter plate in order to achieve greater span widths. Depending on type, the rail is fixed to the Bridge with one or two M10x30 T-bolts.

Materials required: 2 mounted solar fasteners, K2 Bridge, M10 x 30 T-bolt

Alternative system assembly (Cross bracing) with K2 SingleRail



1 Mount rails by cross bracing

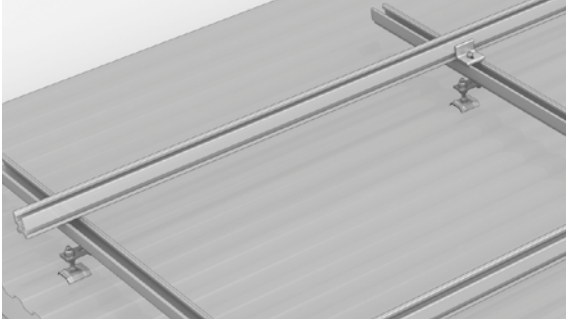

The top rail position in cross bracing is mounted with the M K2 and Climber in the desired location at the appropriate distance.

Tightening torque 16 Nm.

Materials required: SingleRail, Climber Set

Mount rail and climber as shown below:

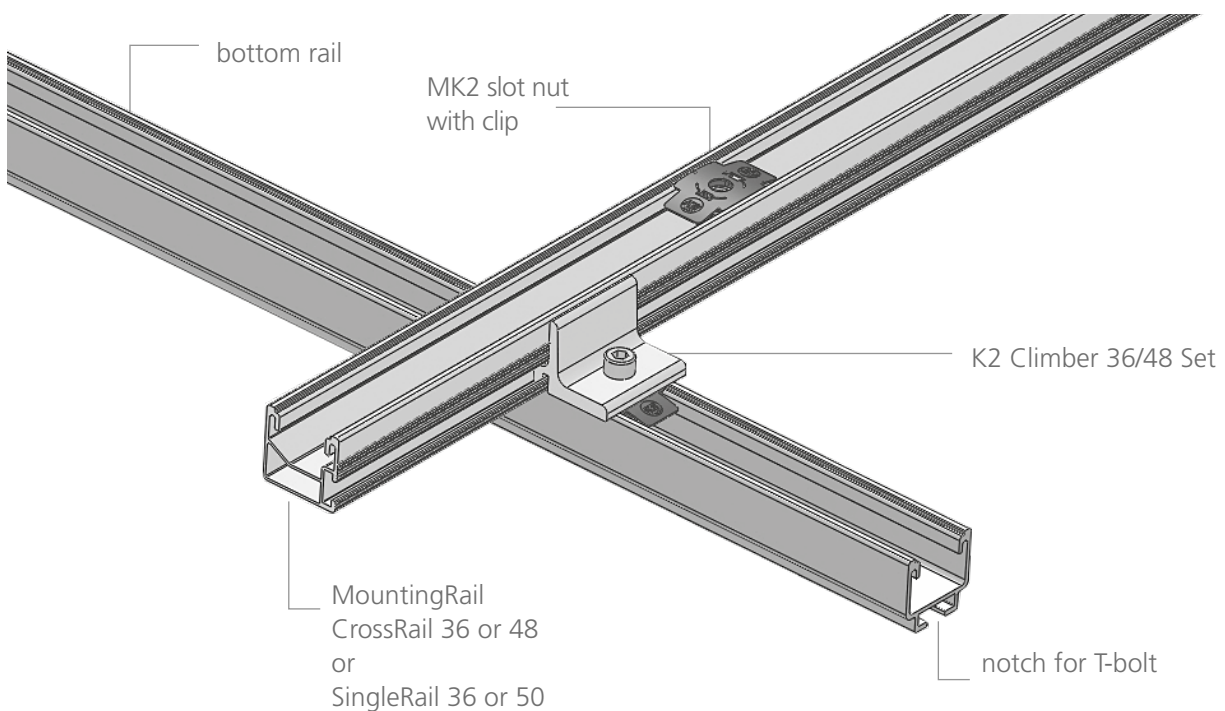

2 Mount rail connector



Lay Mounting Rail on joint with rail connector and connect with T bolts and self-locking nuts. The rail joint may not be in the range of the roof fastener. Tightening torque 16 Nm.

Alternative system assembly (ross bracing) with K2 SolidRail

1 Mount rails by cross bracing

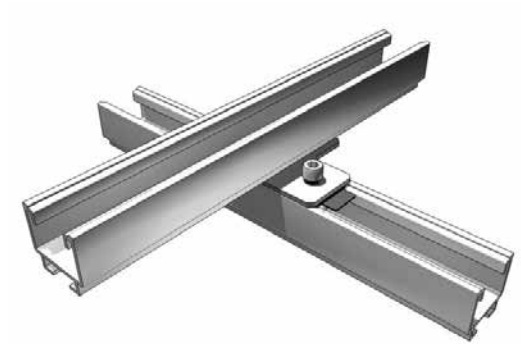

Mount SolidRail as a top rail with the cross-connector set as shown below.

Mount the MK2 into the lower SolidRail, place the cross connector on the SolidRail as shown in the illustration and fasten it with the allen bolt.
Tightening torque: 16 Nm.

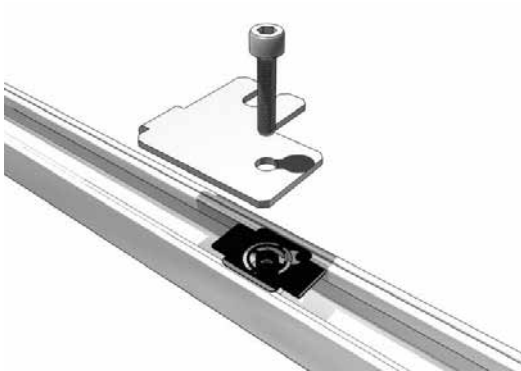

Fasten the upper SolidRail to the cross connector with the t-bolt and the locking nut.
Tightening torque:35 Nm.

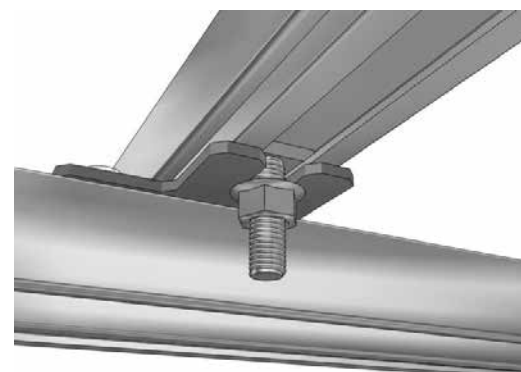
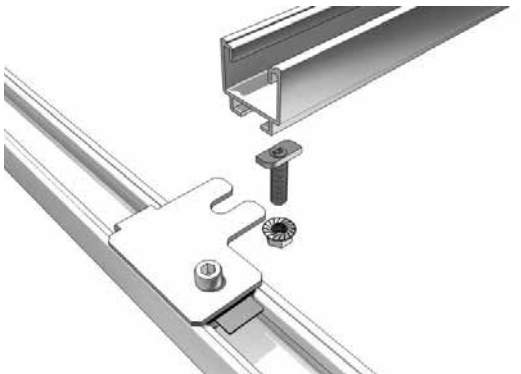

Note

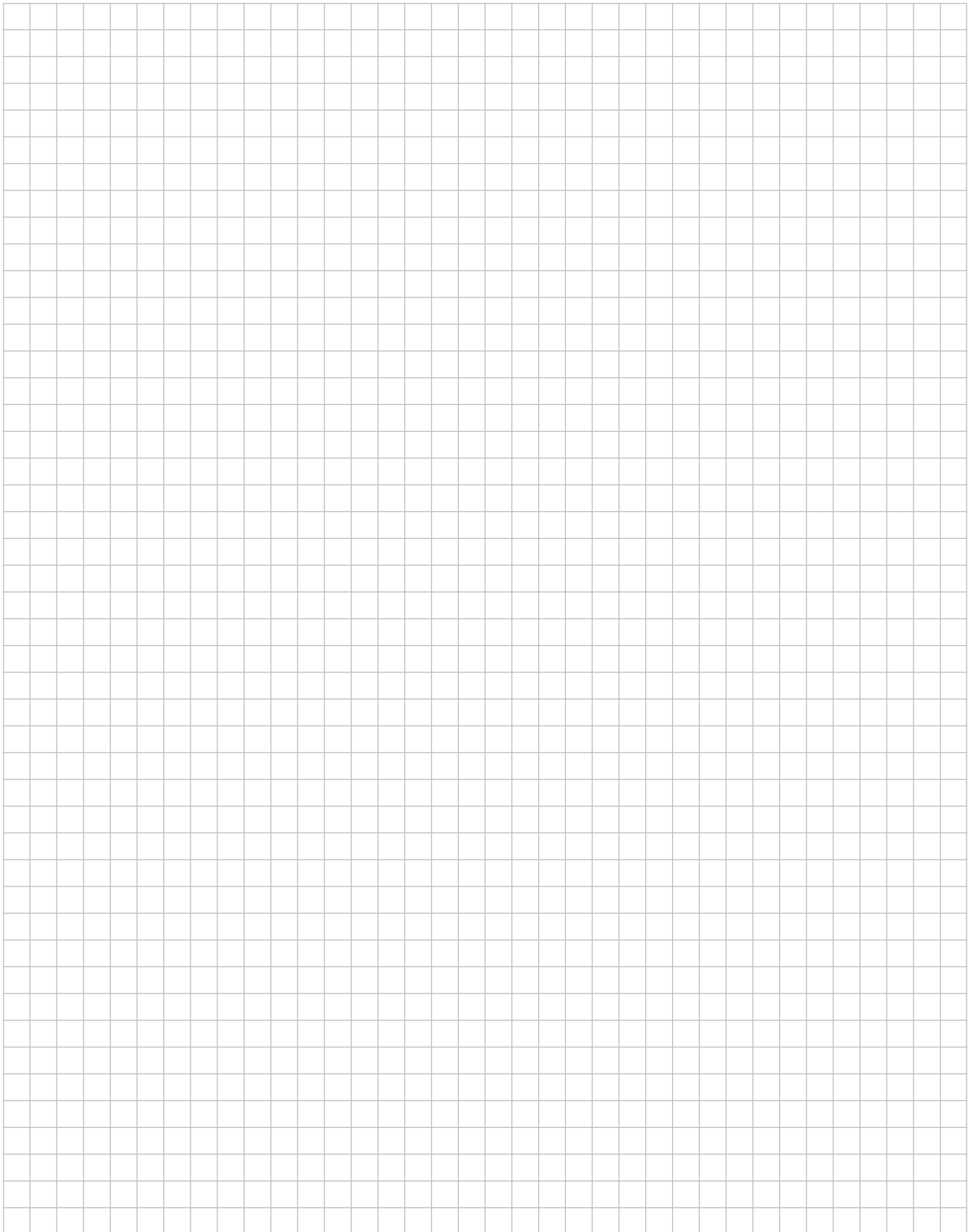

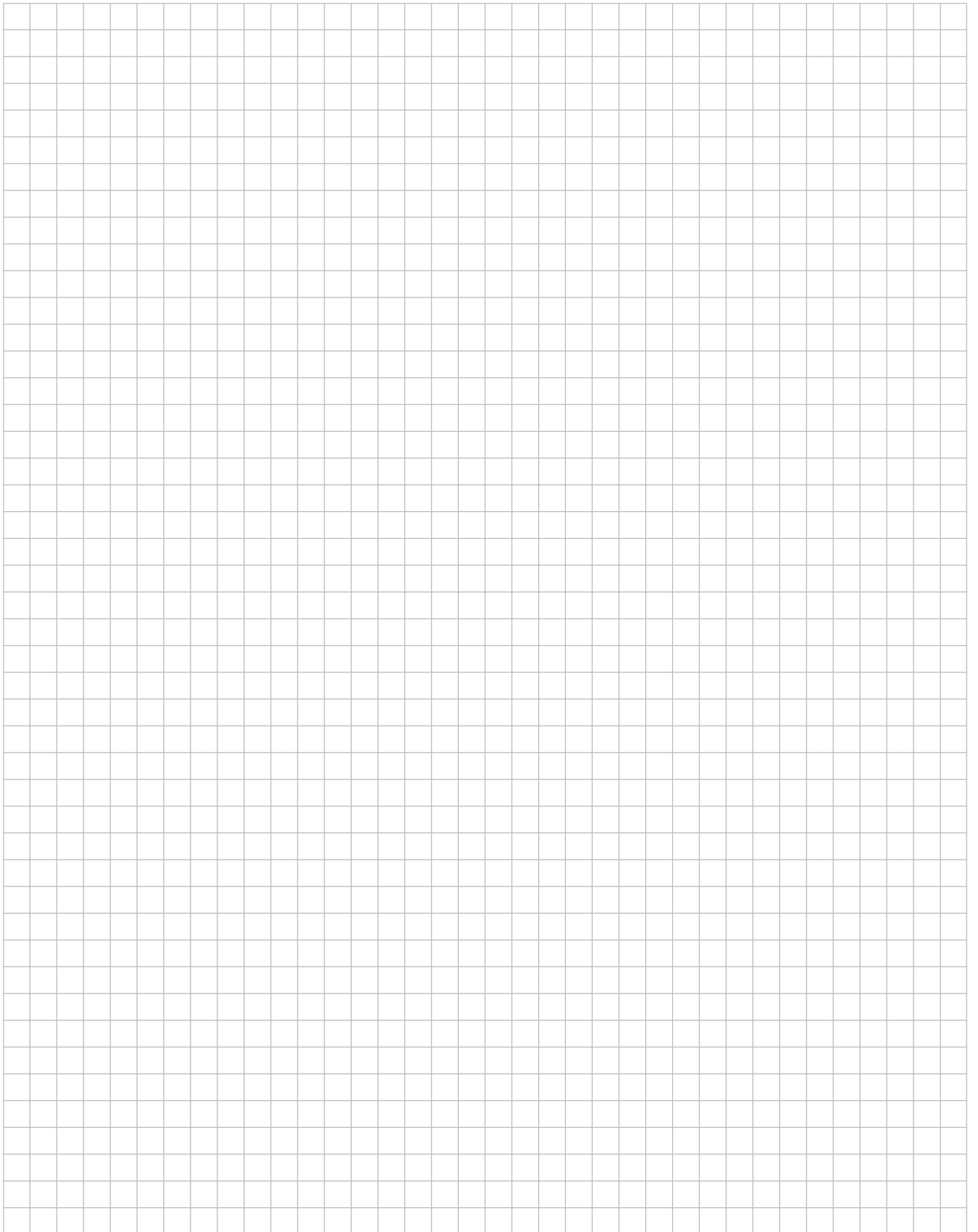

THANK YOU FOR CHOOSING A K2 MOUNTING SYSTEM.

Systems from K2 Systems are quick and easy to install. We hope these instructions have helped. Please contact us with any questions or suggestions for improvement.

Our contact data:

- ▶ www.k2-systems.com/en/contact
- ▶ **Service Hotline: +49 (0)7159 42059-0**

German law shall apply excluding the UN Convention on CISG.
Place of venue is Stuttgart.

Our General Terms of Business apply. Please refer:
www.k2-systems.com

K2 Systems GmbH
Industriestraße 18
71272 Renningen
Germany
Tel. +49 (0) 7159 - 42059 - 0
info@k2-systems.com
www.k2-systems.com