

We support PV systems

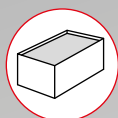

S-Dome 6 System

ASSEMBLY MANUAL

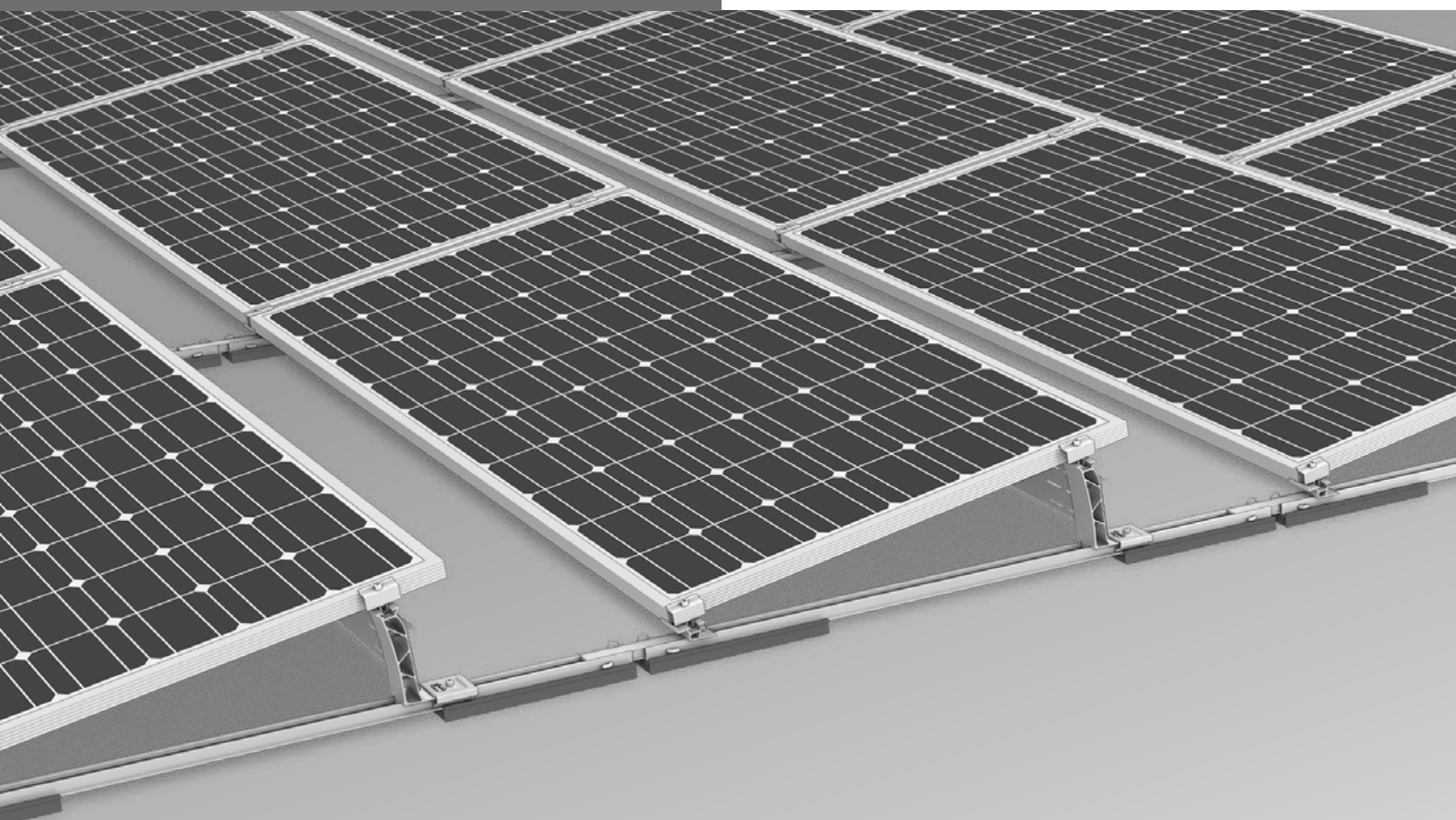

Content

/ Tools overview	3
/ General safety information	4
/ The following guidelines apply	5
· Planning with K2 Base	5
· Roof requirements	5
· Static requirements	5
· Important mounting instructions	5
/ Components	6
· Base components	6
· Ballast	8
· Edge bracing	9
· Fixed connection to the roof	10
/ Assembly	11
· Installation of module field and thermal separations	11
· Ballast options	15
· Ballasting specifications	16
· Module assembly	17
· Assembly Windbreaker	18
/ Optional assembly steps	19
· Fixed connection with Dome FixPro using Solmont mounting base	19
· Edge bracing	20
· Cable management	21
· Module frame earthing with TerraGrif	21
/ Notes	22

Quality tested – several certifications

K2 Systems stands for secure connections, highest quality and precision. Our customers and business partners have known that for a long time. Independent institutes have tested, confirmed and certified our capabilities and components.

Please find our quality and product certificates under:
k2-systems.com/en/technical-information

Tools overview

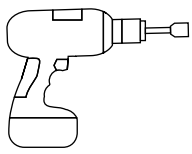

6 mm

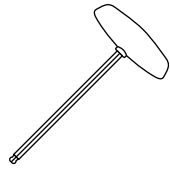

6 mm

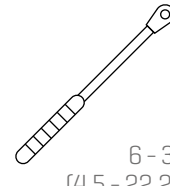

6 - 30 Nm
(4.5 - 22.2 lb-ft)



6 mm

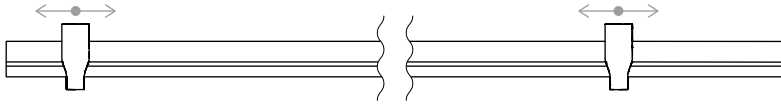

Dome Speed Spacer 2.25 / 2.50 · 2003253 / 2004219

Distance template for module lengths

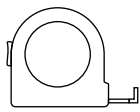

≥ 3.0 m



≥ 6.0 m

K2 App and Base – Digital planning workflow

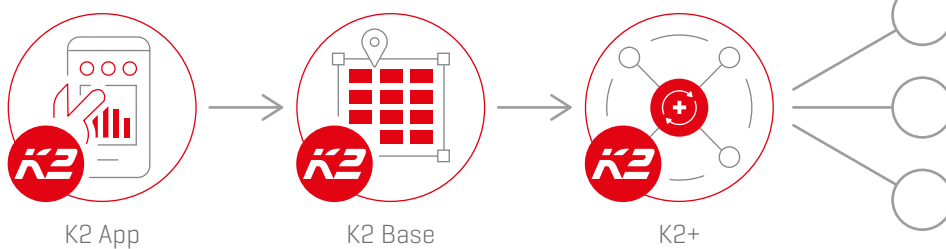

Do you already know our digital services? Use our K2 Roof Check App now and record the first important data directly at the customer or project site. Simply transfer the data to our online planning software K2 Base. Here you can plan your project easily, safely and quickly. You receive a detailed project report with assembly plan and static report. The K2+ interface enables seamless project data transfer to the planning tools of well-known inverter manufacturers or yield planning tools.

Get started and register now:

app.k2-systems.com →

base.k2-systems.com →

General safety information

Please note that our general mounting instructions must be followed at all times and can be viewed online at k2-systems.com/en/technical-information

- The equipment may only be installed and operated by qualified and adequately trained installers.
- Prior to installation, ensure that the product complies with on-site static loading requirements. For roof-mounted systems, the roof load-bearing capacity must always be checked.
- National and local building regulations and environmental requirements must be adhered to.
- Compliance with health and safety regulations, accident prevention guidelines and applicable standards is required.
 - Protective equipment such as safety helmet, boots and gloves must be worn.
 - Roofing works must be in accordance with roofing regulations utilising fall protection safeguards when eaves height exceeds 3 m.
 - At least two people must be present for the duration of the installation work in order to provide rapid assistance in the event of an emergency.
- K2 mounting systems are continuously developed and improved and the installation process may thereby change at any time. Prior to installation consult our website at www.k2-systems.com/en/technical-information for up-to-date instructions. We can send you the latest version on request.
- The assembly instructions of the module manufacturer must be adhered to.
- Equipotential bonding/grounding/earthing between individual parts is to be performed according to country specific standards, as well as national laws and regulations.
- At least one copy of the assembly instructions should be available on site throughout the duration of the installation.
- Failure to adhere to our general safety and assembly instructions and not using all system components, K2 is not liable for any resulting defects or damages. We do not accept liability for any damage resulting in the use of competitor's parts. Warranty is excluded in such cases.
- German law shall apply excluding the UN Convention on CISG. Place of venue is Stuttgart. Our General Terms of Business apply.
- If all safety instructions are adhered to and the system is correctly installed, there is a product warranty entitlement of 12 years! We strongly recommend reviewing our terms of guarantee, which can be viewed at www.k2-systems.com/en/technical-information We will also send this information on request.
- Dismantling of the system is performed in reverse order to the assembly.
- K2 stainless steel components are available in different corrosion resistance classes. Each structure or component must be carefully checked for possible corrosion exposure.

The following guidelines apply

The S-Dome 6 system can be installed as standard under the following conditions. Even if the system is capable of meeting higher demands through the integration of safety standards, please get in touch with your contact at K2 Systems if the specified values are exceeded.



Planning with K2 Base

We recommend our free online software K2 Base for the planning. In five steps, you can plan the right assembly system and get a construction recommendation, parts list and the structural analysis report. Simply register and start planning:
base.k2-systems.com

- Ensure a thermal separation (distance between module blocks) after a maximum of 15 m in the module row direction and in the direction of the base rail.
- In the event of exceptional circumstances (such as storms, heavy rain, earthquakes, etc.), the system should be checked by a specialist. Should an inspection find damage or plastic deformation (such as in the module clamp area) the components must be replaced.



Roof requirements

- This system can be installed on all common flat roofs with a pressure-resistant base and a roof pitch of $\leq 3^\circ$ without fixed connection. Up to 5° roof pitch is possible with the Dome FixPro Set and a corresponding mechanical fastening on the roof.
- The roof surface must be clean and dry. Roof irregularities must be corrected or removed where appropriate.
- The coefficient of friction of the roof must be determined on-site. See video
k2-systems.com/en/friction-coefficient

Modules and clamping

- Tightening torque of 14 Nm for all module clamps.
- Adhere to module manufacturer recommendations for clamping area and module installation [see module manufacturer instructions]. Check whether manufacturer approval is available for clamping on the short module side. See
k2-systems.com/en/approved-modules-dome-6



Static requirements

- It is essential to check that the roof structure has sufficient residual load capacity and that the pressure capacity of the roof insulation (where present) is not exceeded.
- Suitable for framed modules with a frame height 30 - 50 mm
- Permissible module dimensions:
length 1448 - 2390 mm, width 950 - 1170 mm

General information

- External influences that act on this system are only reflected in the design of the ballast to a limited degree. For instance, unevenness, thermal elongation, moss, water accumulation and ageing of the sheeting cannot be considered, although these factors might also precipitate system displacement under certain circumstances. We therefore recommend regular maintenance of the system or to check whether additional mechanical fastening is necessary.
- It is important to ensure that the rain water flow is not hindered.
- Because of the different orientation of the solar modules, the string and inverter connection must be appropriately observed. It is recommended that the inverters and strings are connected separately.
- On-site general standards and regulations for lightning protection must be observed and consultation with a specialist to create a lightning protection concept is recommended (use lightning protection clamp if necessary).



Important mounting instructions

Mounting system

- Row spacing and elevation angle

Module width	Row spacing	Elevation angle
950 - 1060 mm	1.48 m	10°
1061 - 1170 mm	1.53 m	9°

- The compatibility of the roof covering and the Mat S support pad must be checked.
- An array must consist of at least two elevations must for this mounting system to be properly utilized.

Components

Base components

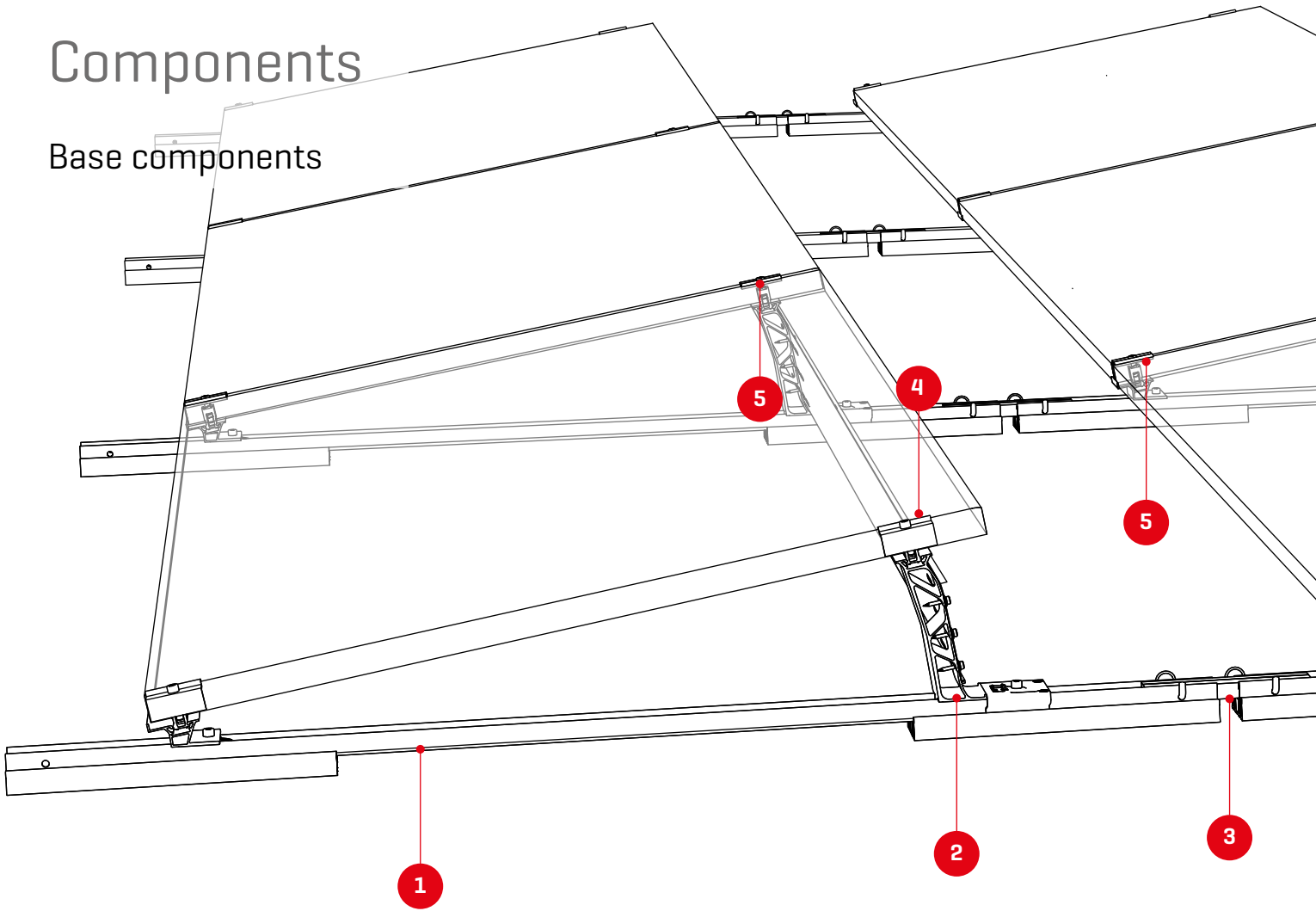

1 2003247 / 2004096
S-Dome 6.10 Base Set and Base Set L



2 2003248
Dome 6.10 Peak

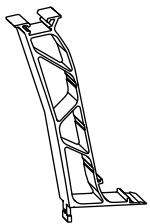

3 2004123
Dome 6 Connector Set

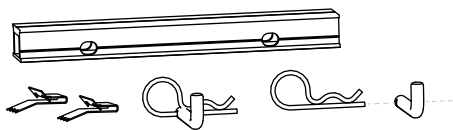

4 **5** 2002559 / 2002558
MiniClamp EC / MC

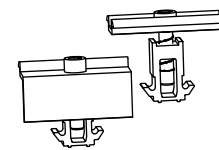

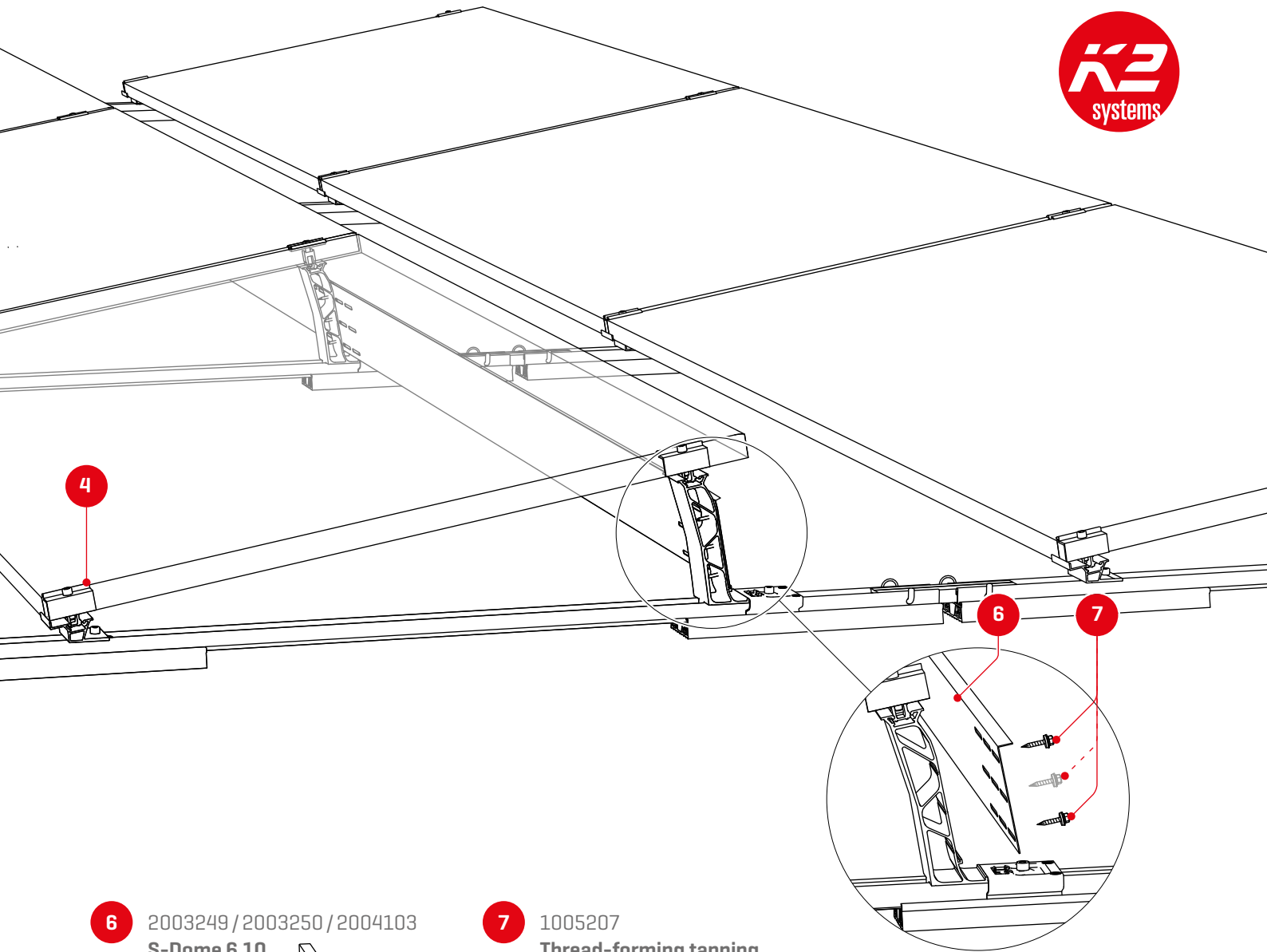

6 2003249 / 2003250 / 2004103
S-Dome 6.10
 Windbreaker
 Short / Long /
 X-tra Long

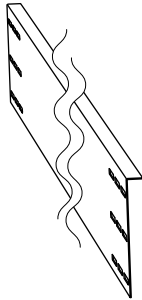

7 1005207
 Thread-forming tapping
 screw with sealing



Dome 6 distance template

2003253 / 2004219
Dome Speed Spacer 2.25 / 2.50

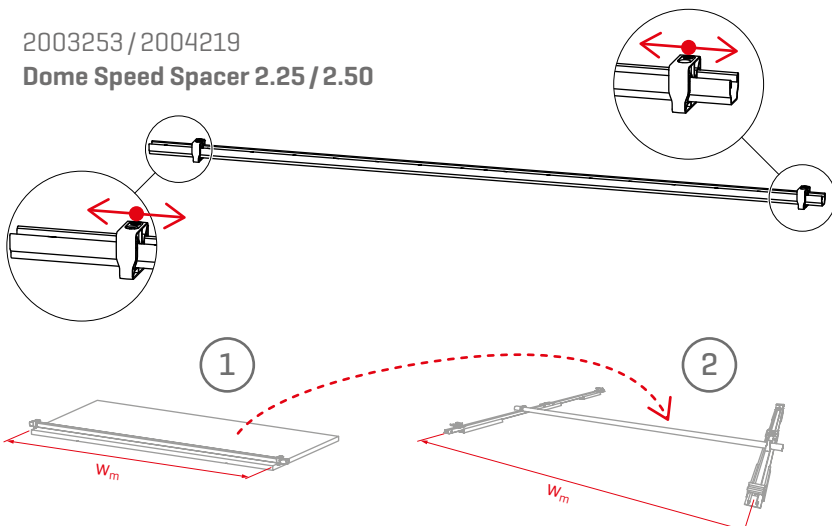

Optional

2002870
Cable-Manager

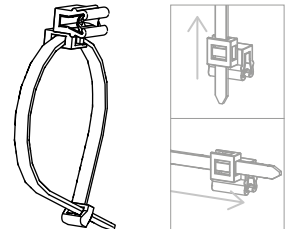

2002649
TerraGrif K2MI



Components

Ballast

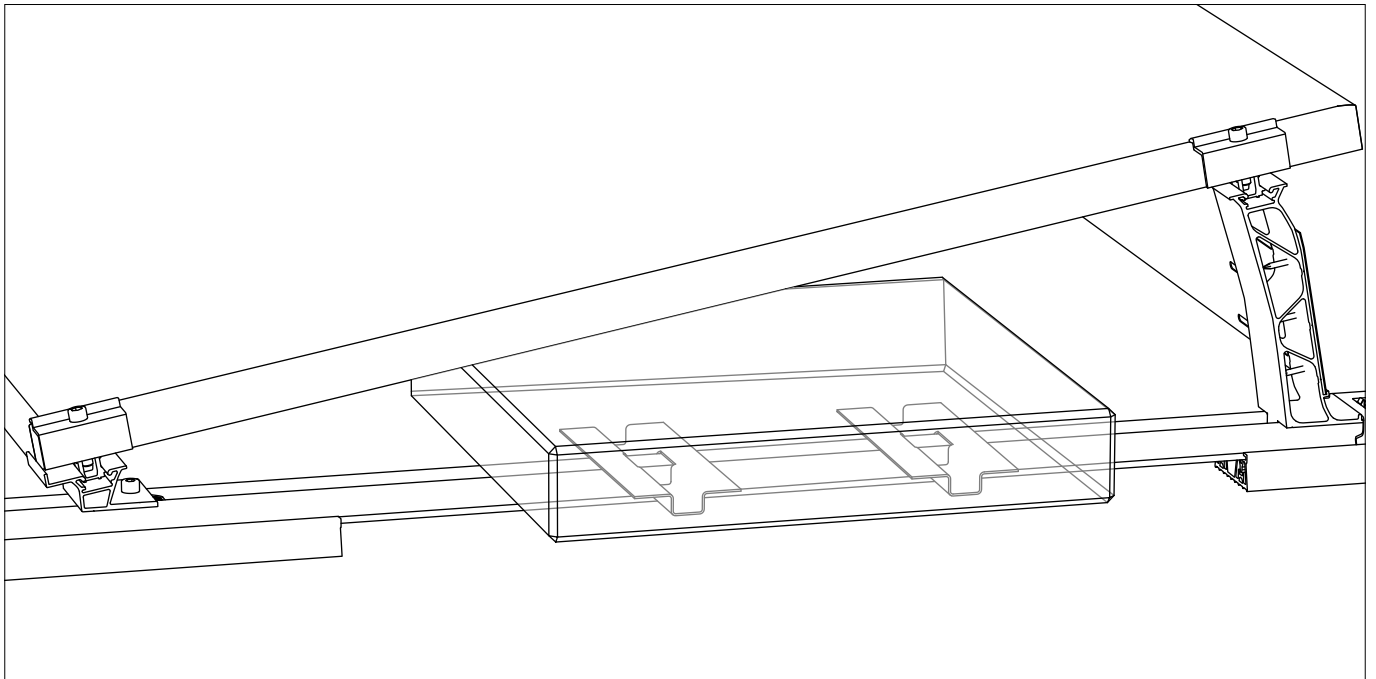

2002300
SpeedPorter

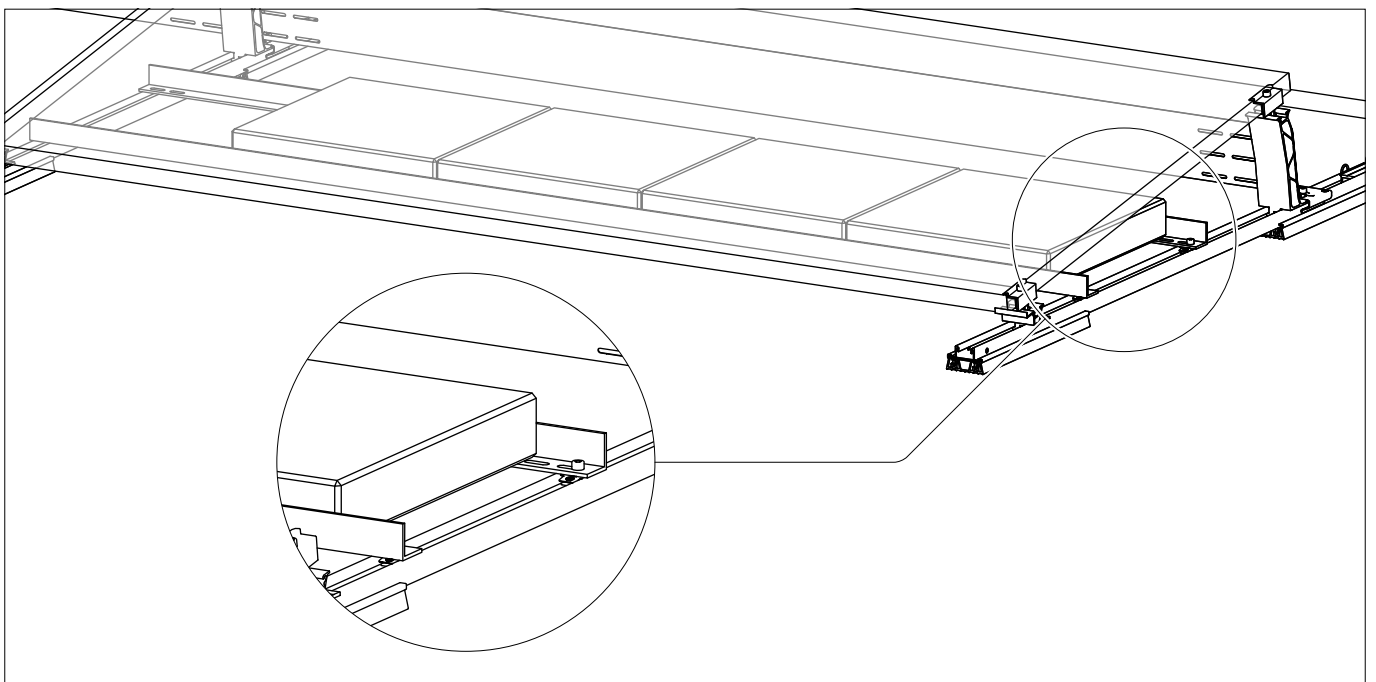
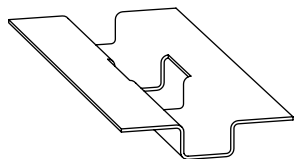

2003150/2003151
Porter

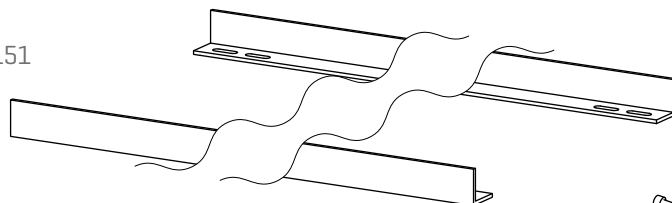

1001643 + 2001729
MK2 Slot nut with clip +
Allen bolt M8×20

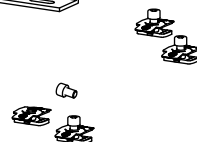

Edge bracing

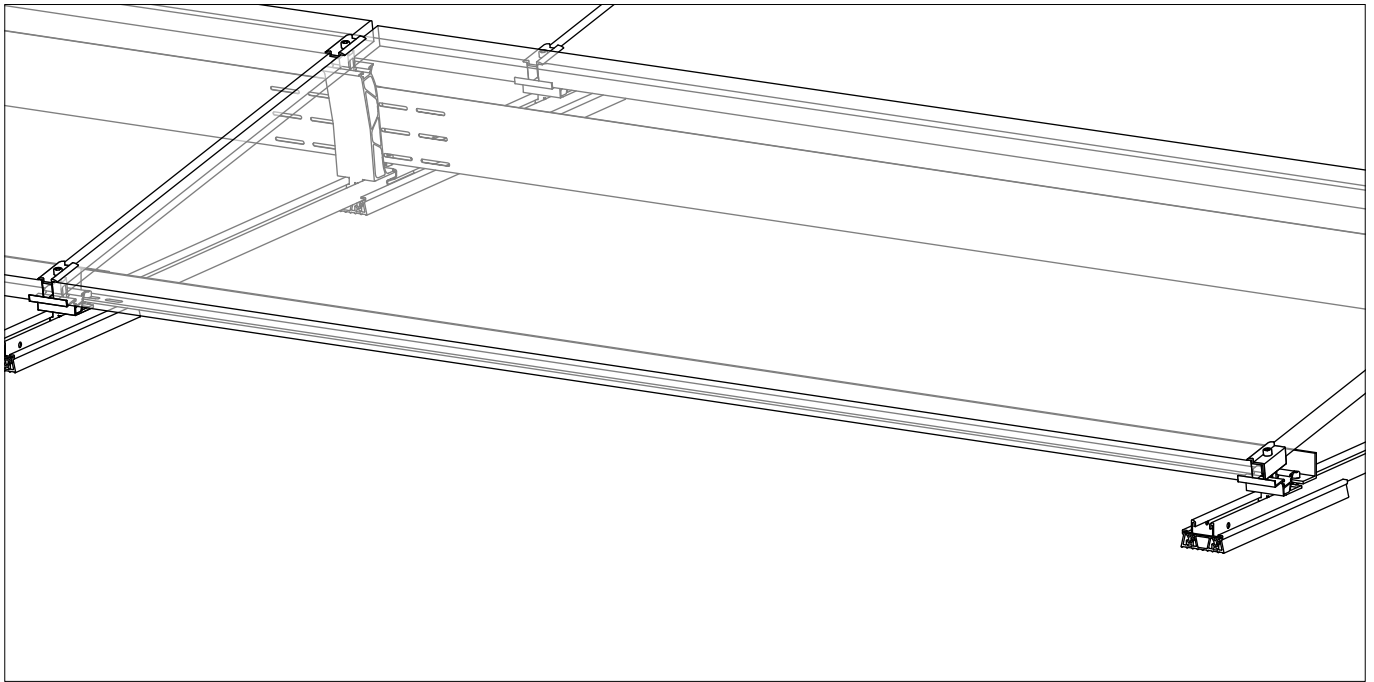

2003150 / 2003151
Porter

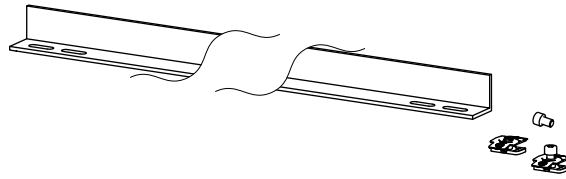

1001643 + 2001729
**MK2 Slot nut with clip +
Allen bolt M8×20**

Fixed connection to the roof

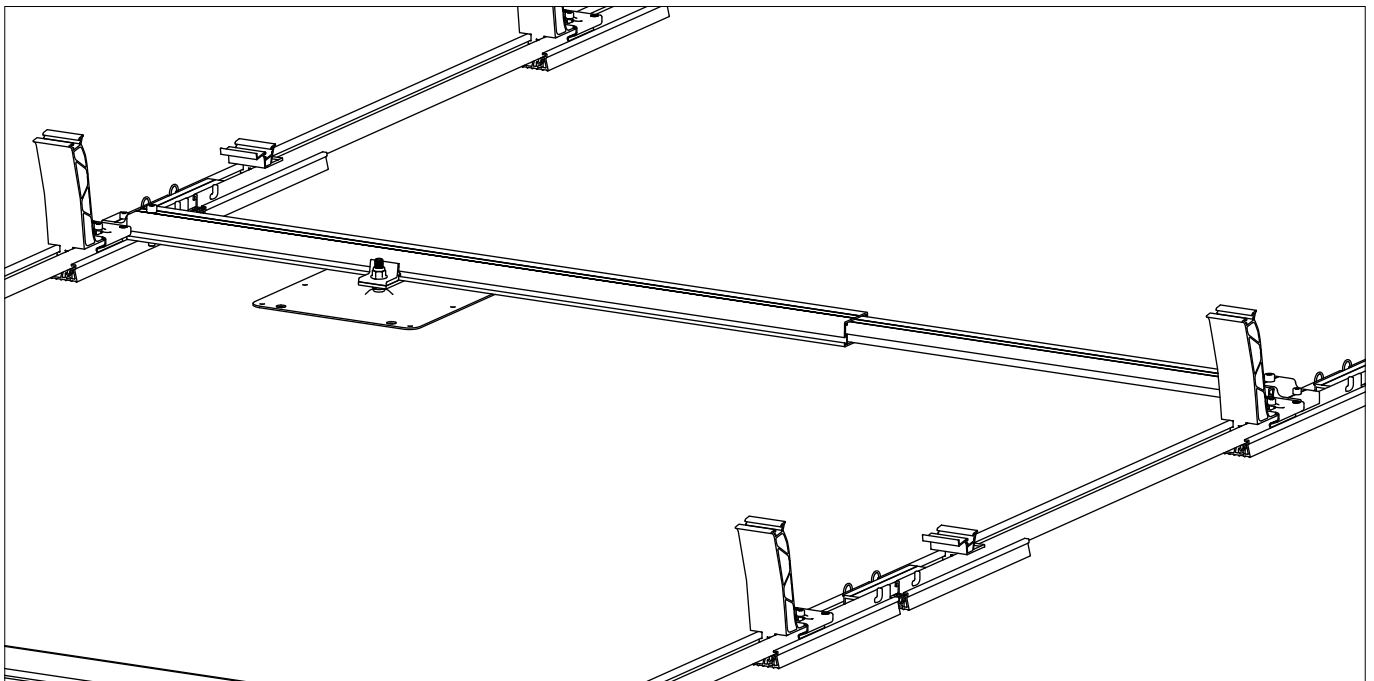

- 1 2003211
Dome FixPro
- 2 2002546 / 2002547
Adapter plate M10/12
- 3 2003146 / 2003147
Climber M10/12

4 Other fastening elements [e.g. screws and nuts] for fixing to the fastener must be provided by the customer.

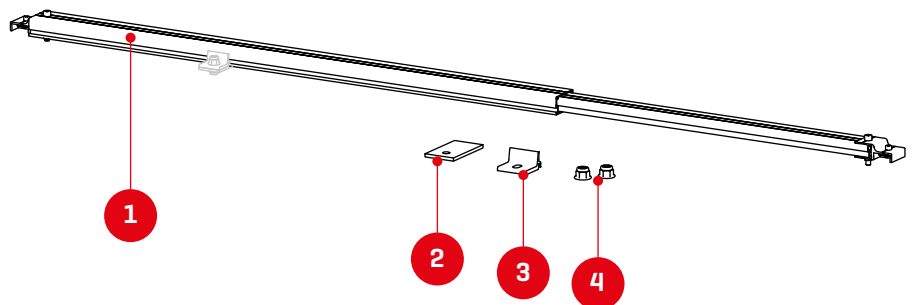

Installation of module field and thermal separations

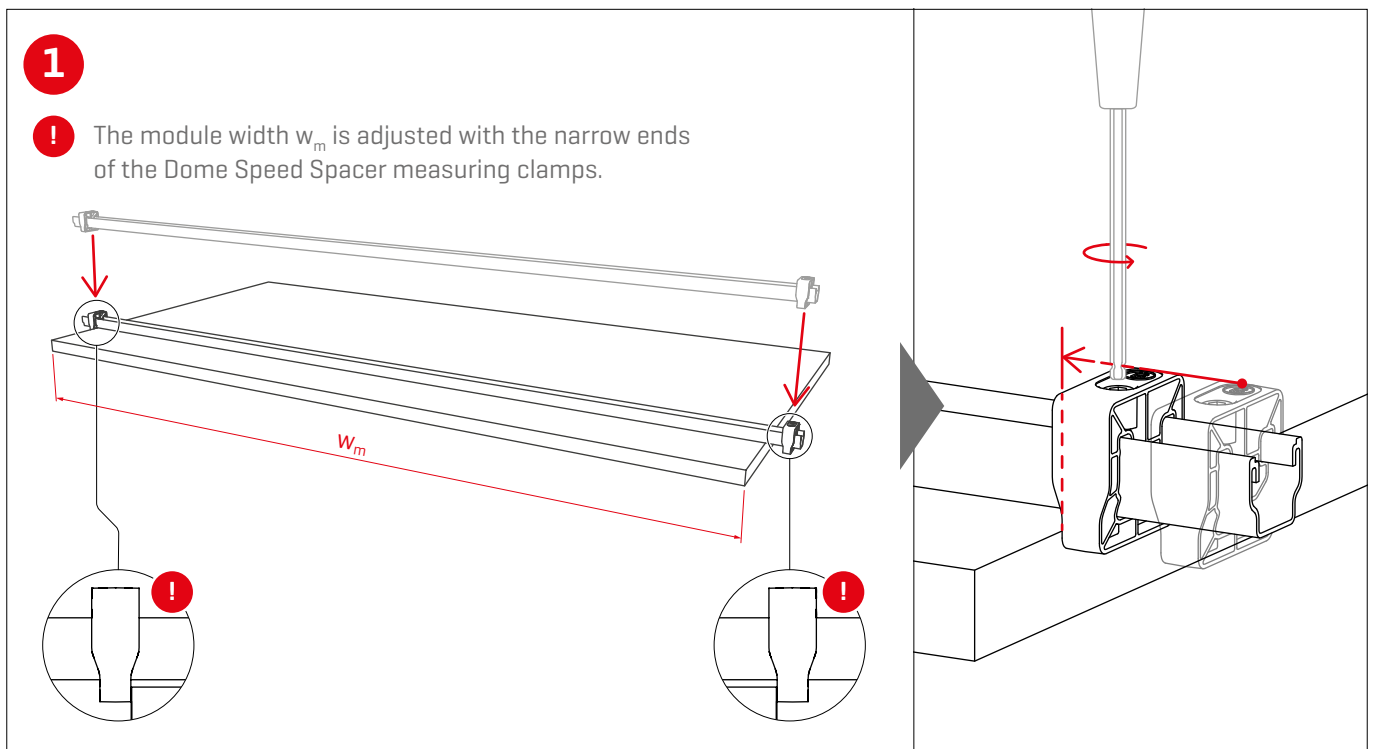
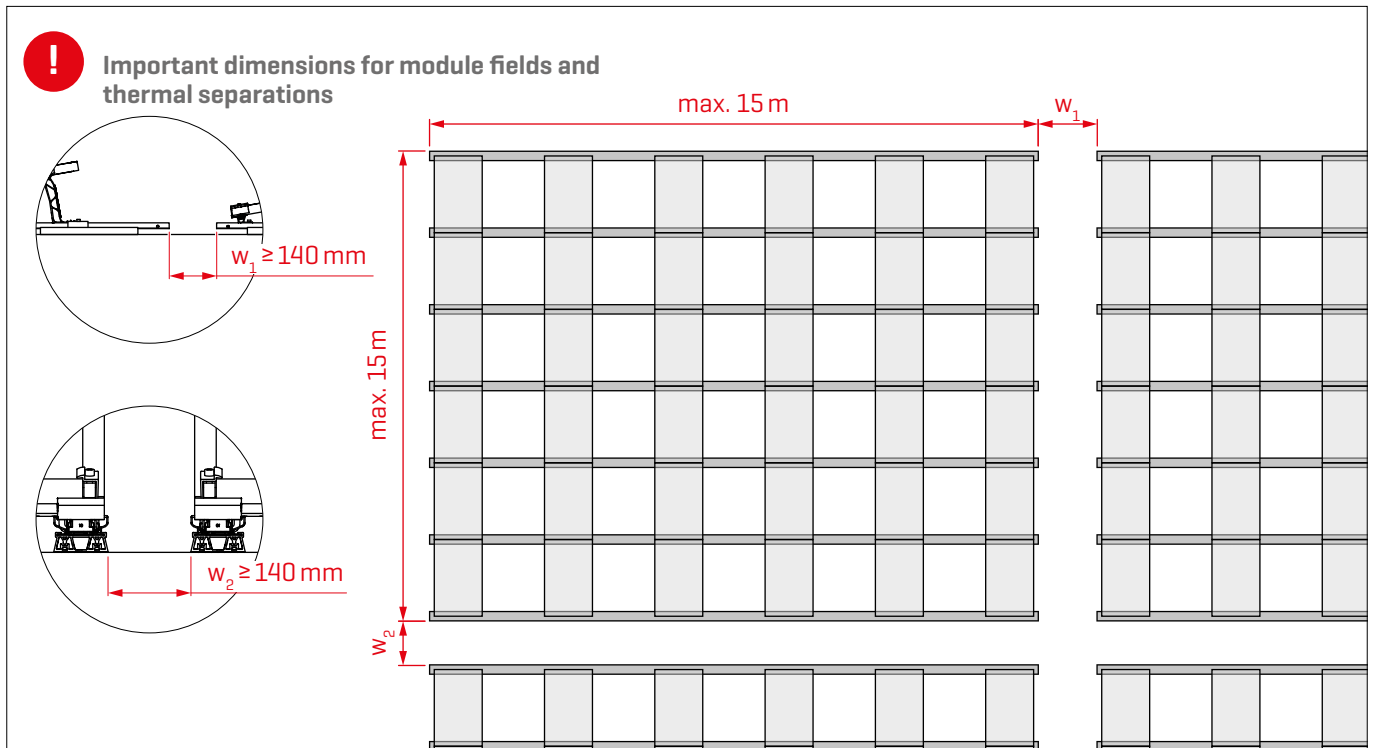

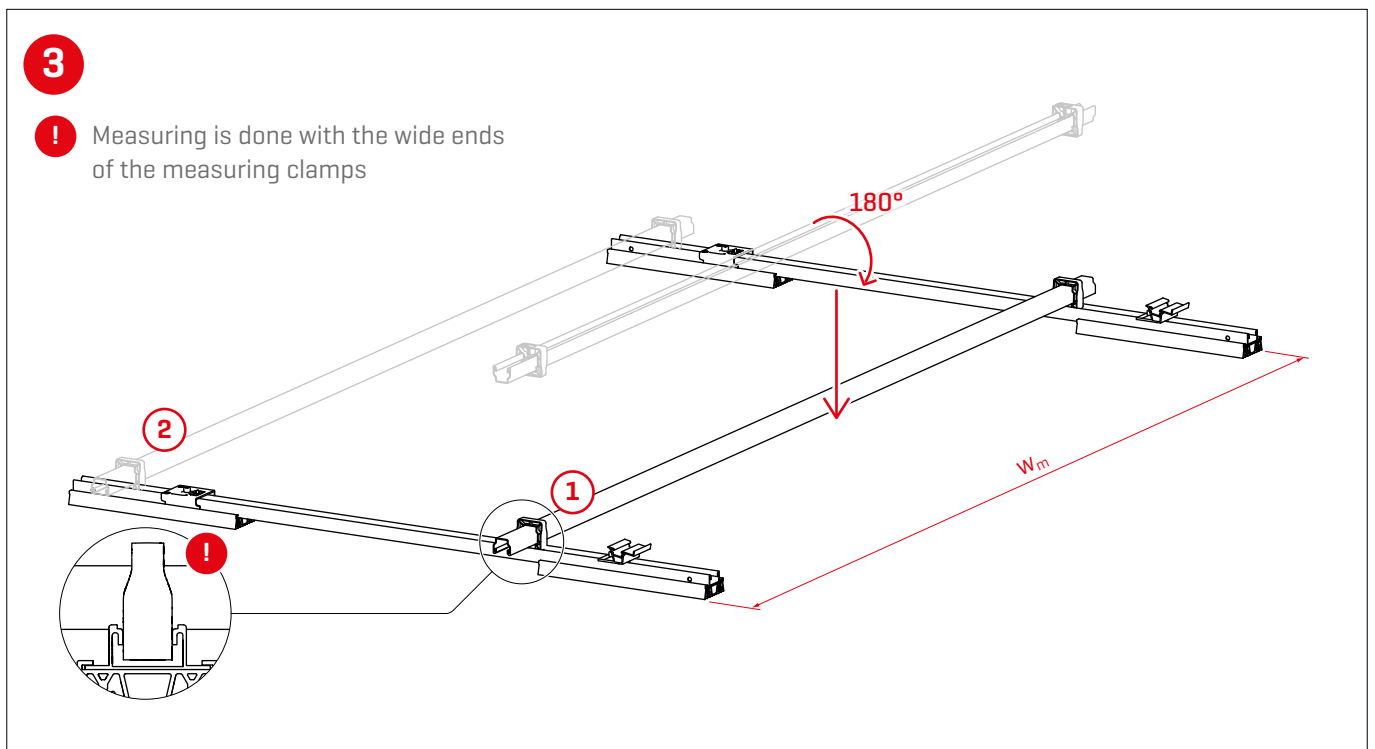
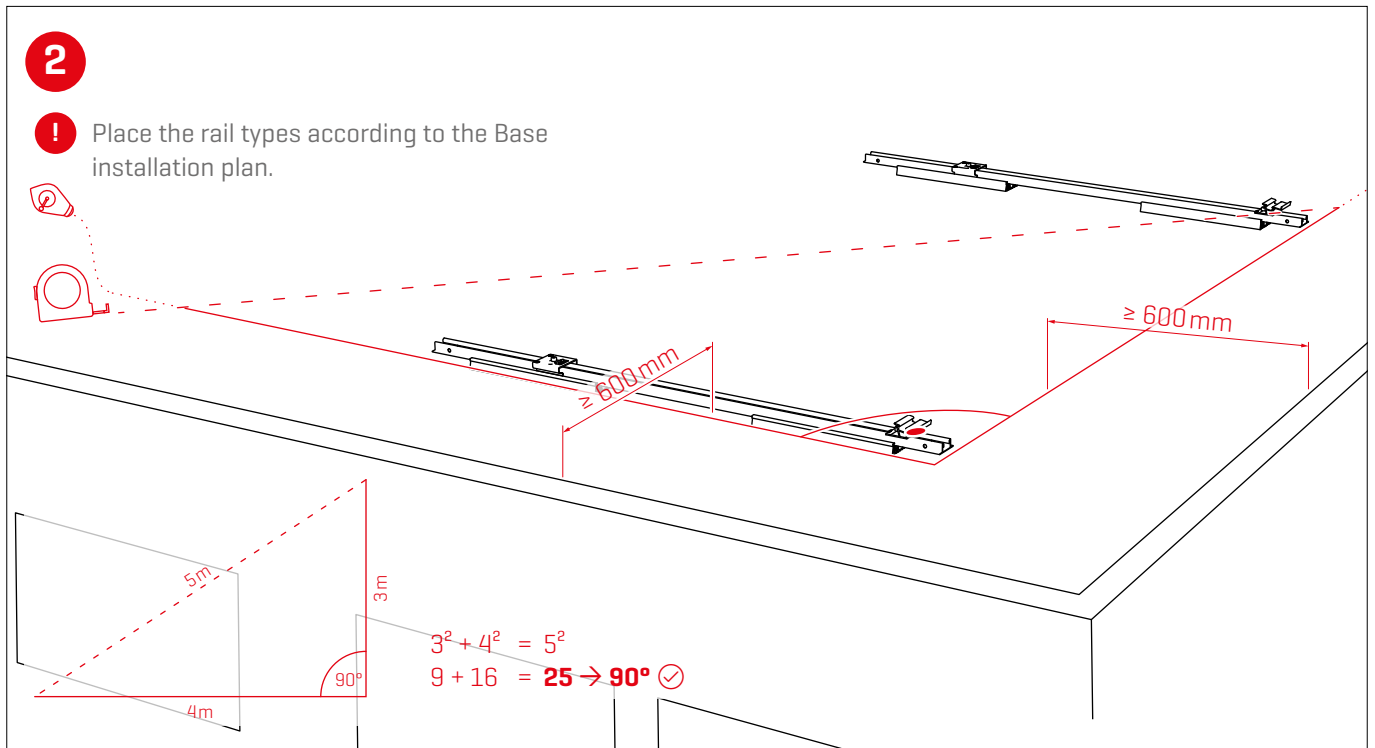

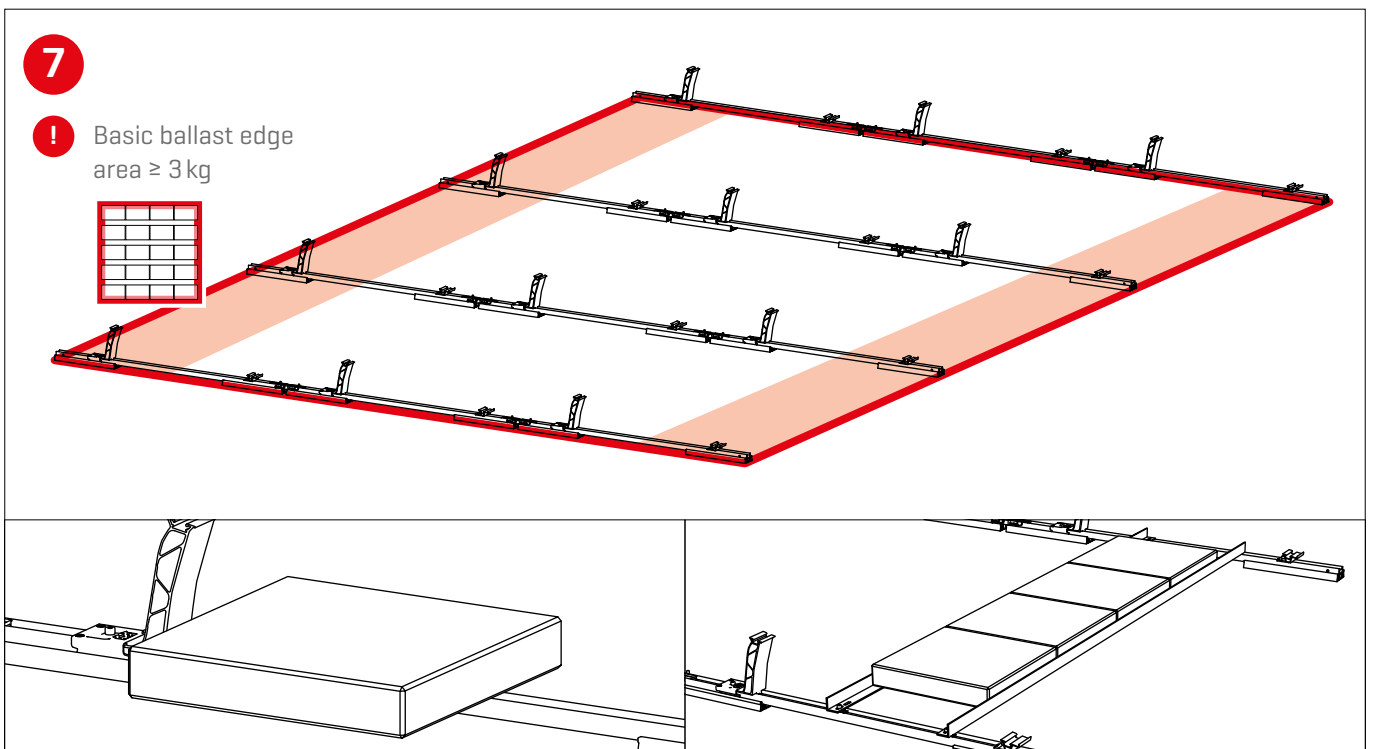
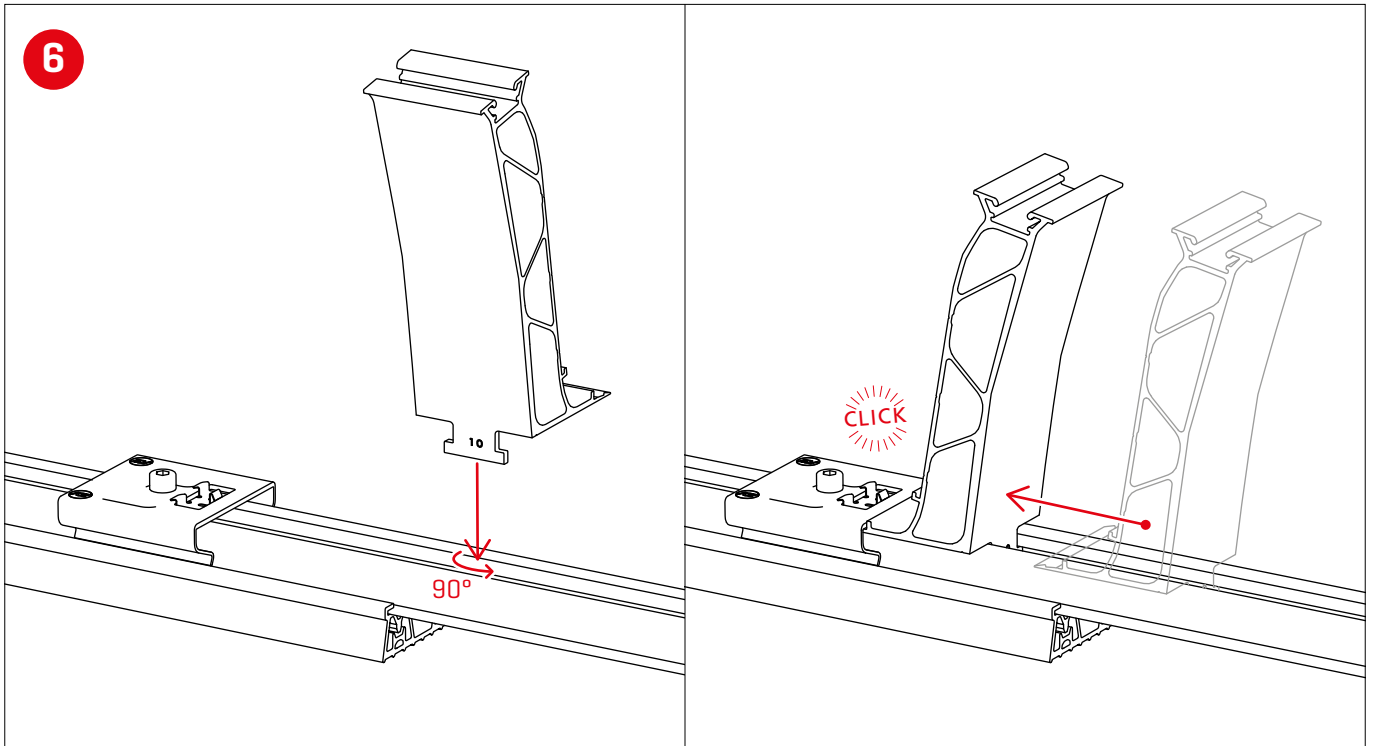

Ballast options

Ballast data: See Base ballast plan!

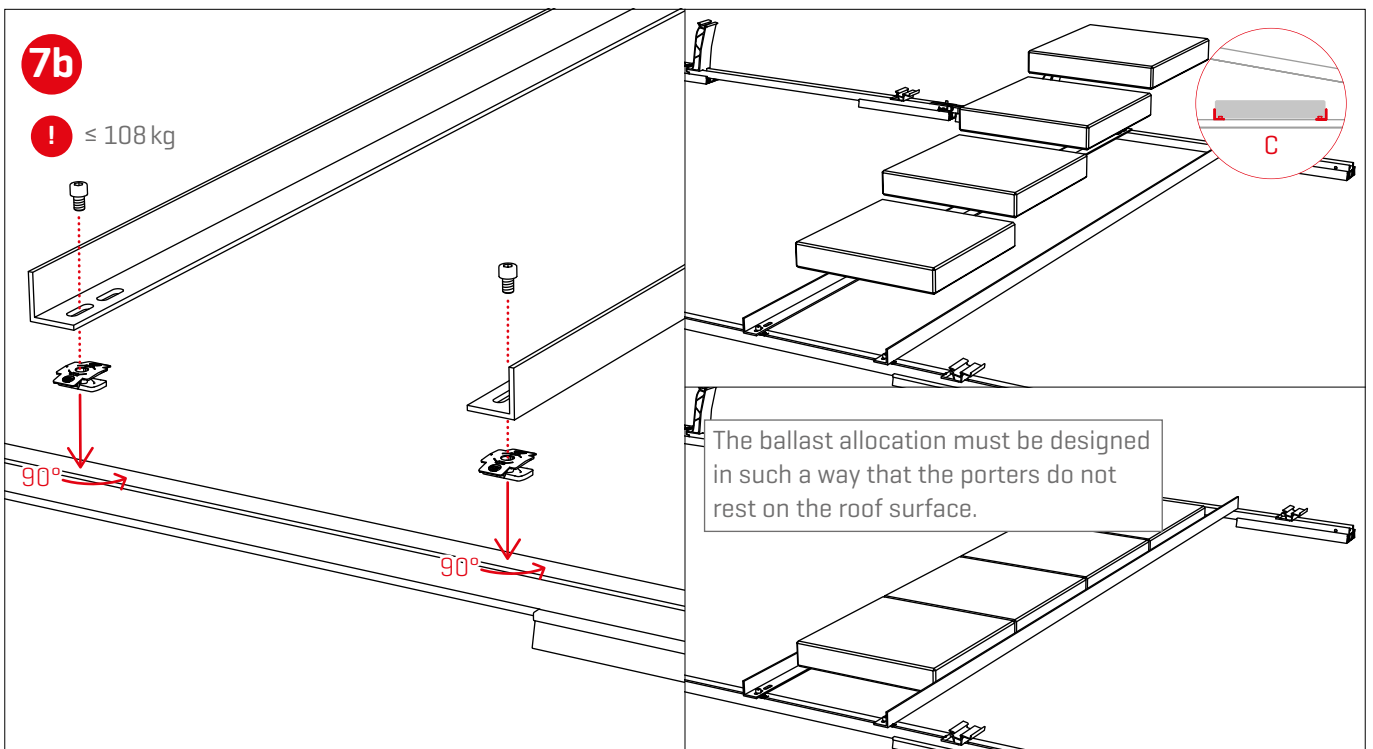
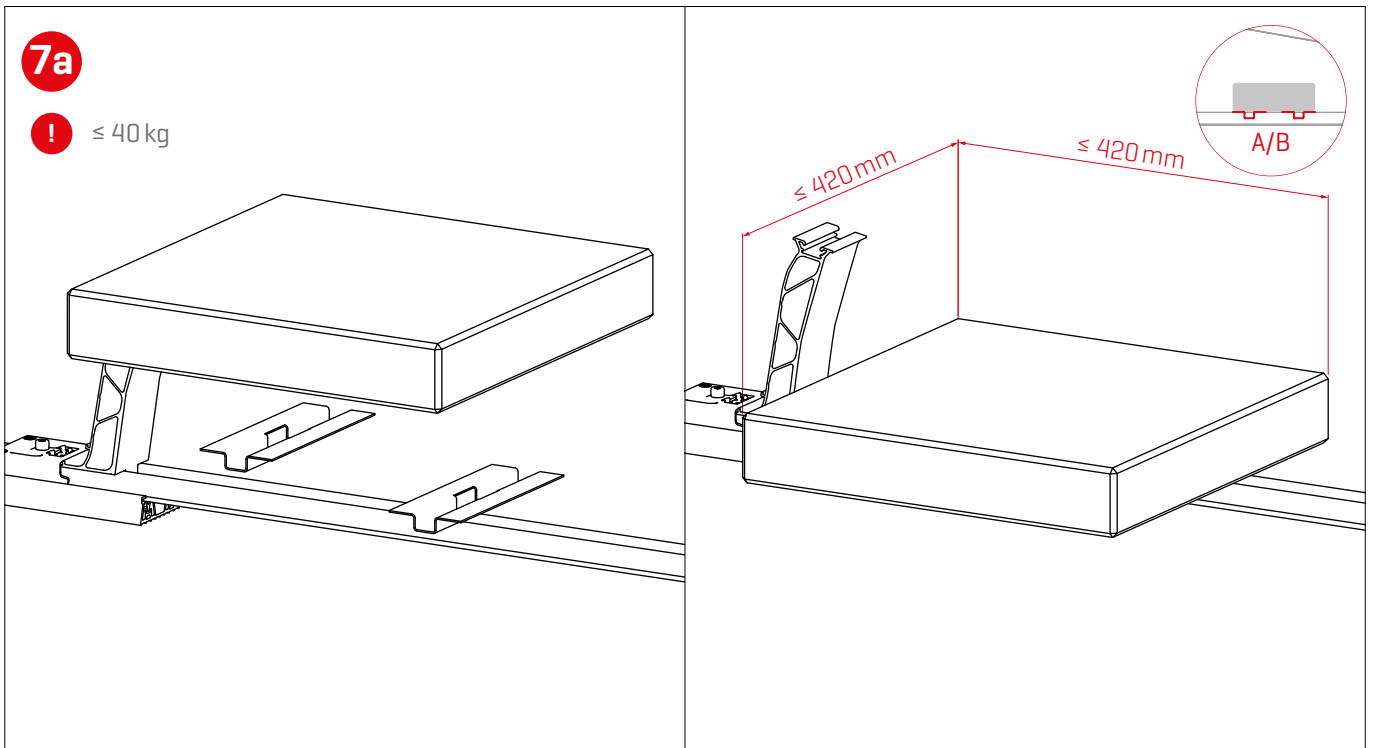

Ballasting specifications

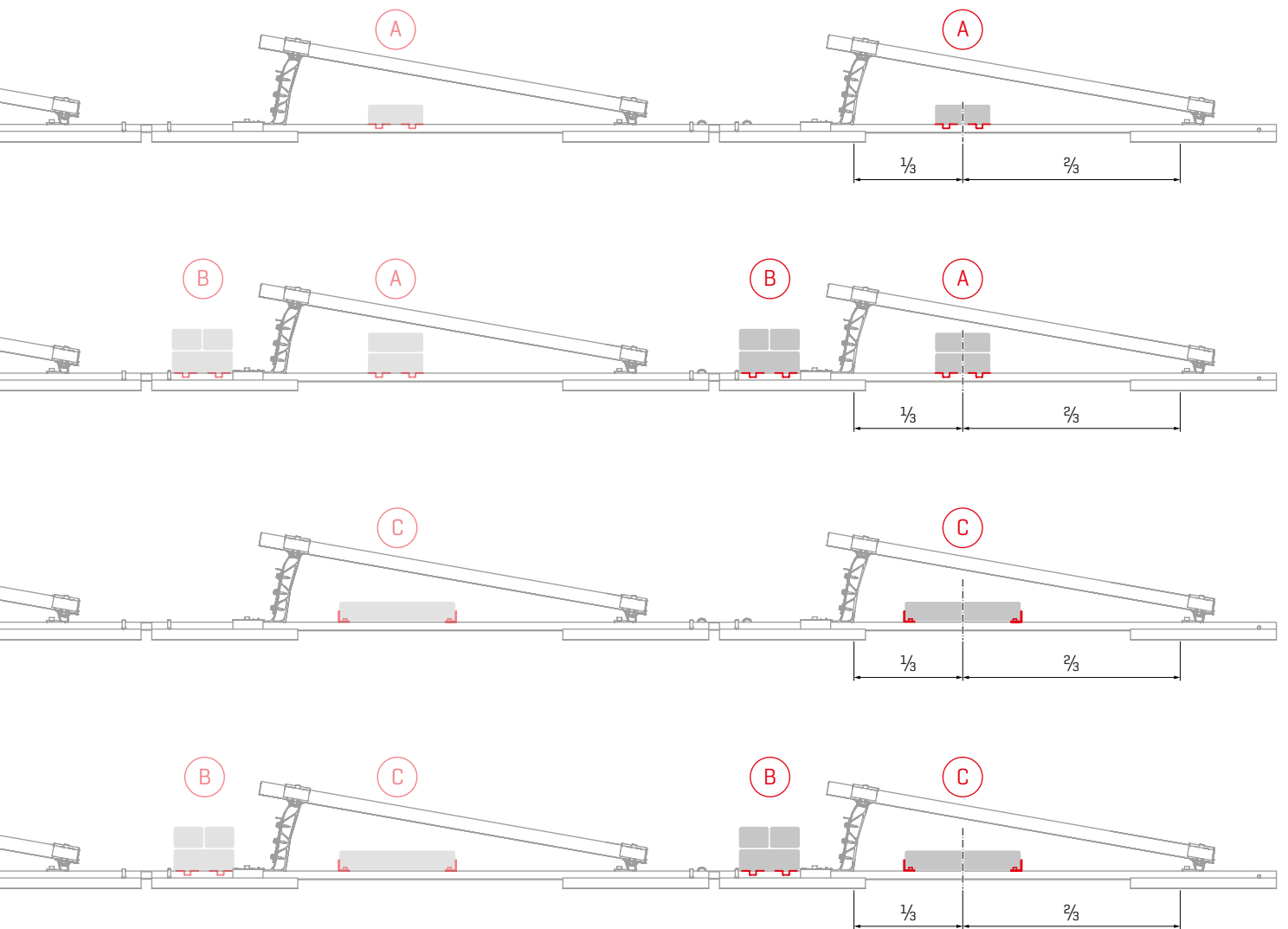
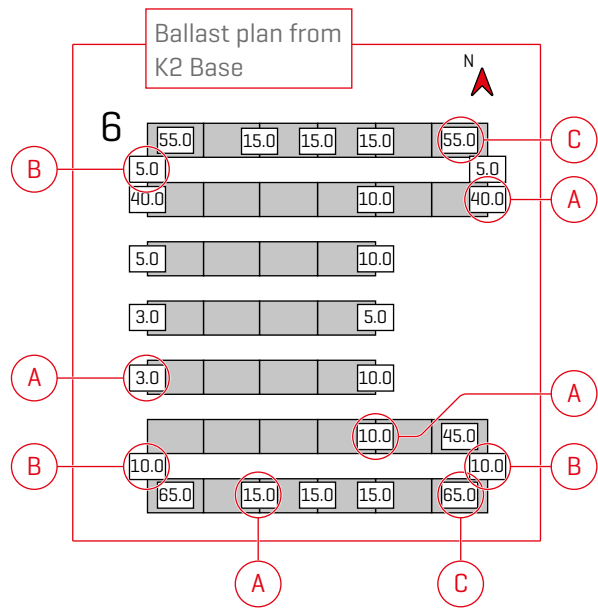

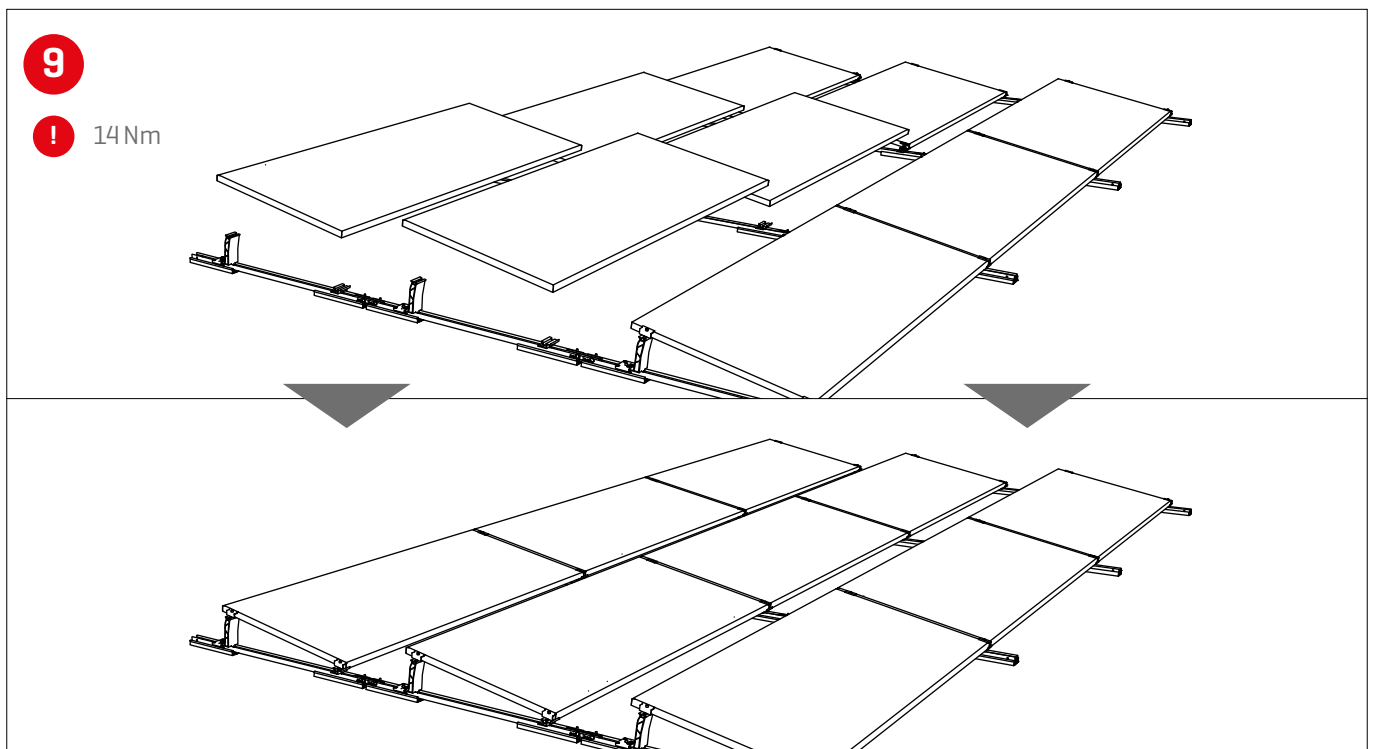
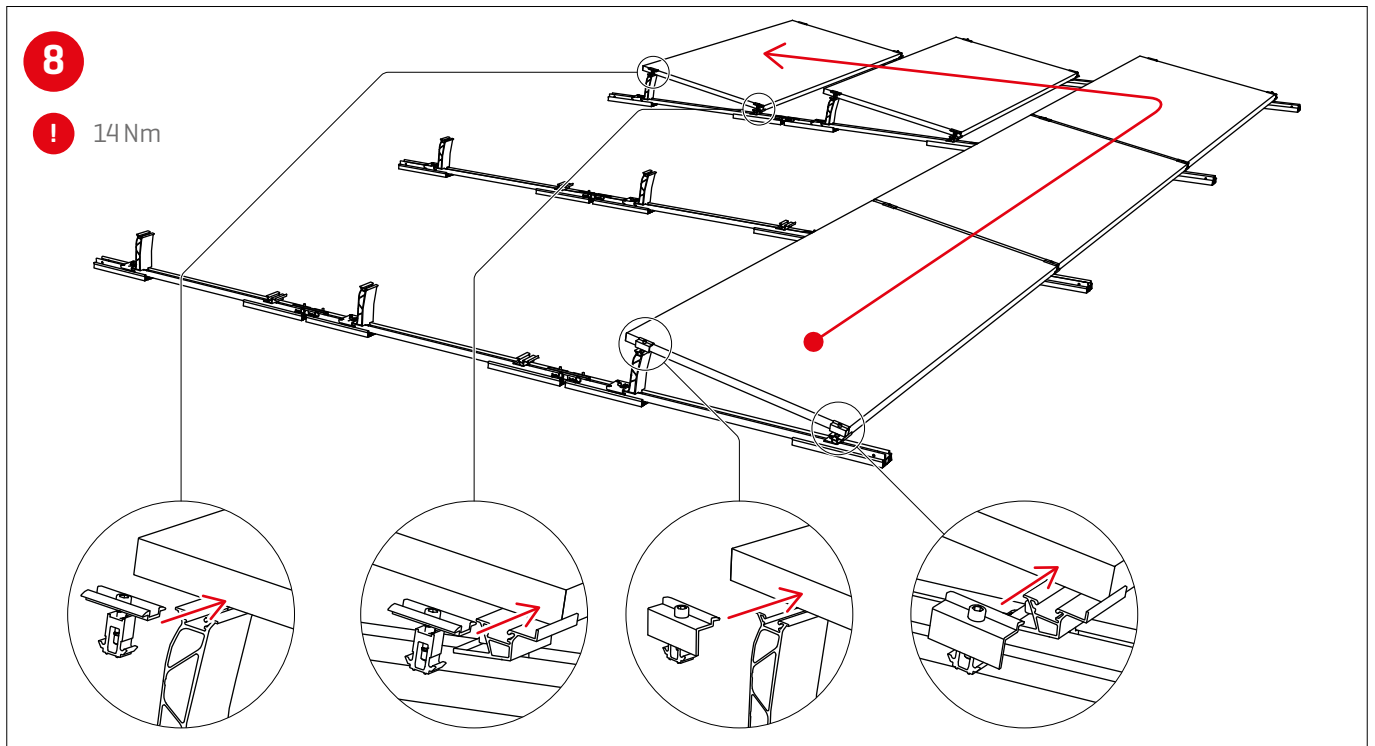

Assembly Windbreaker

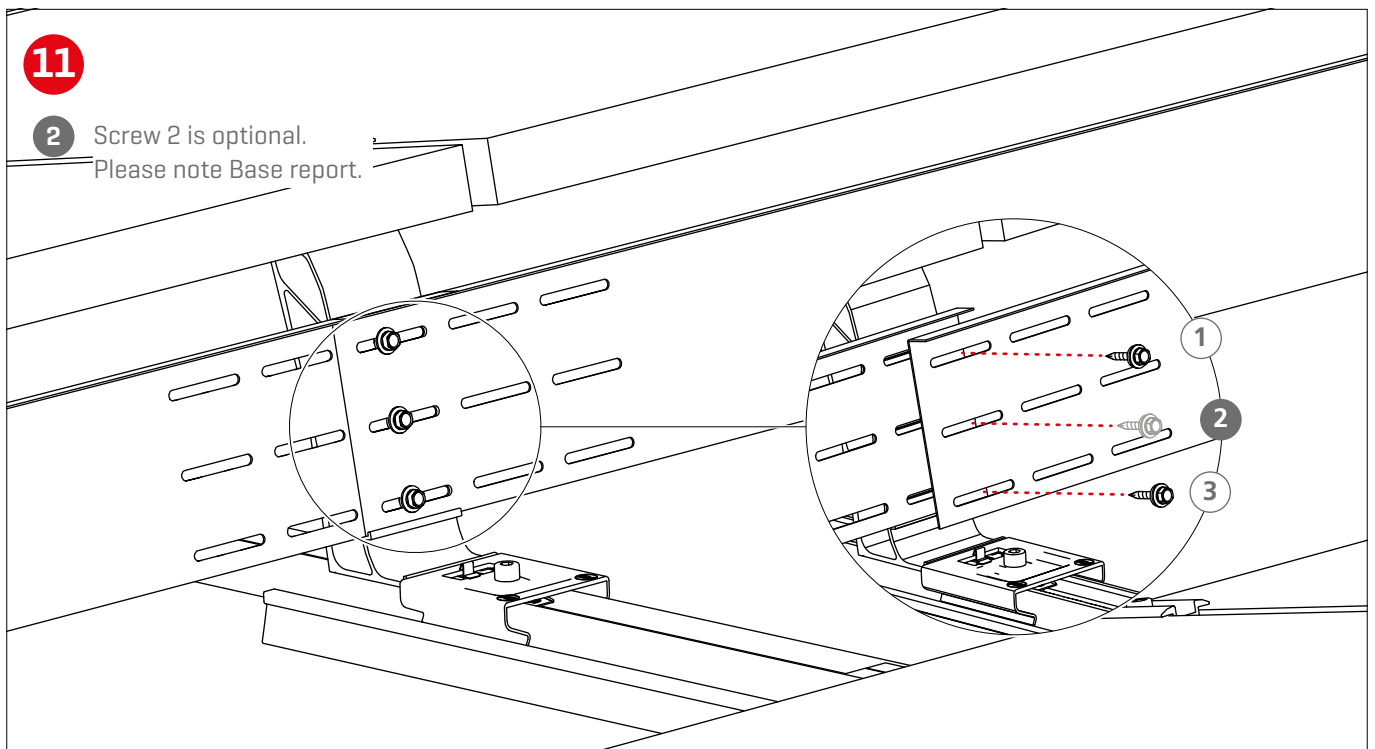
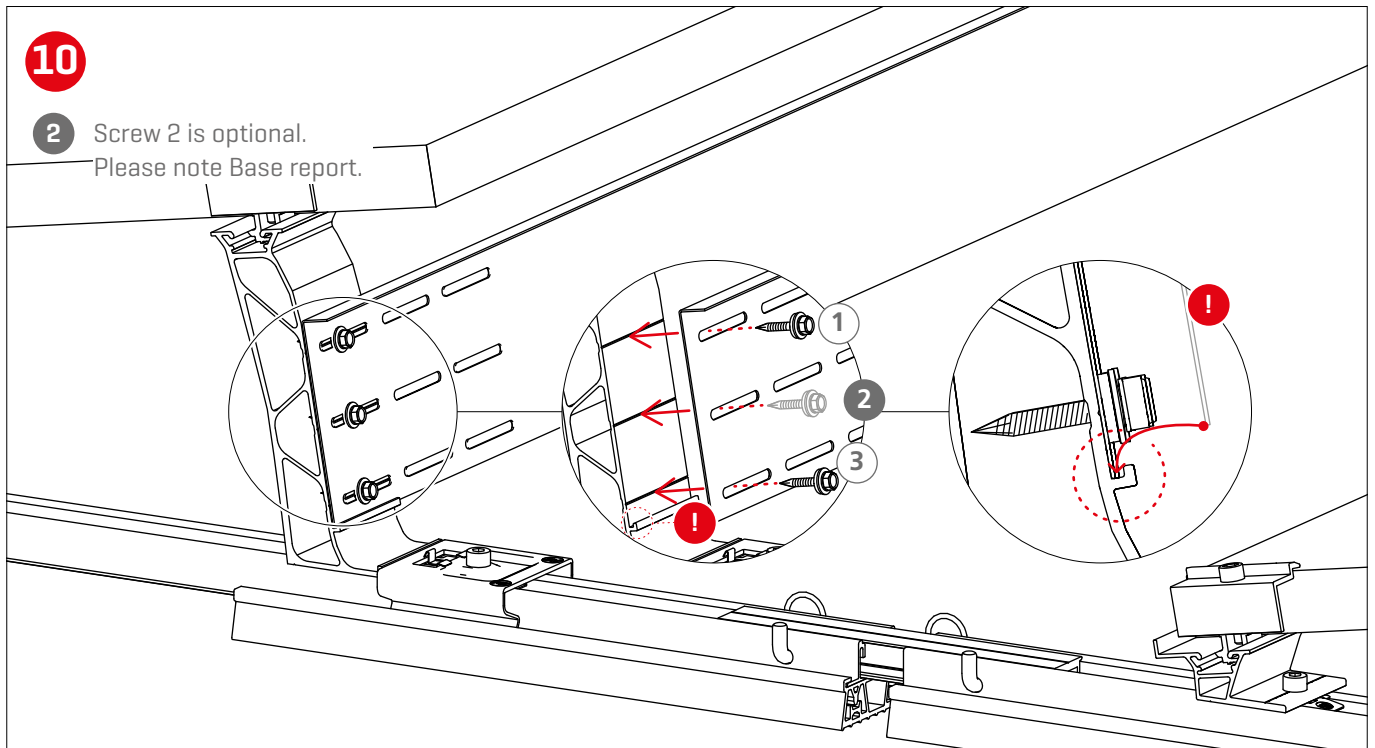

Optional assembly steps



Fixed connection with Dome FixPro using Solmont mounting base

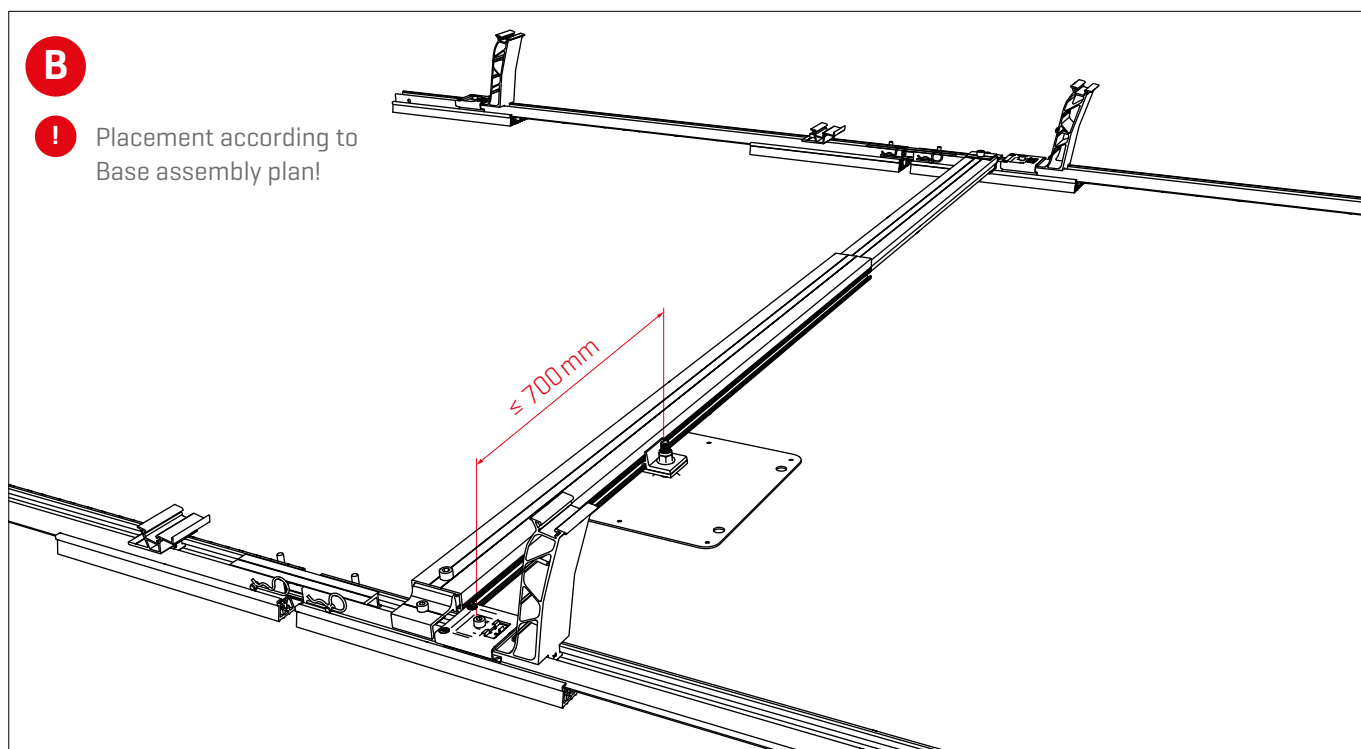
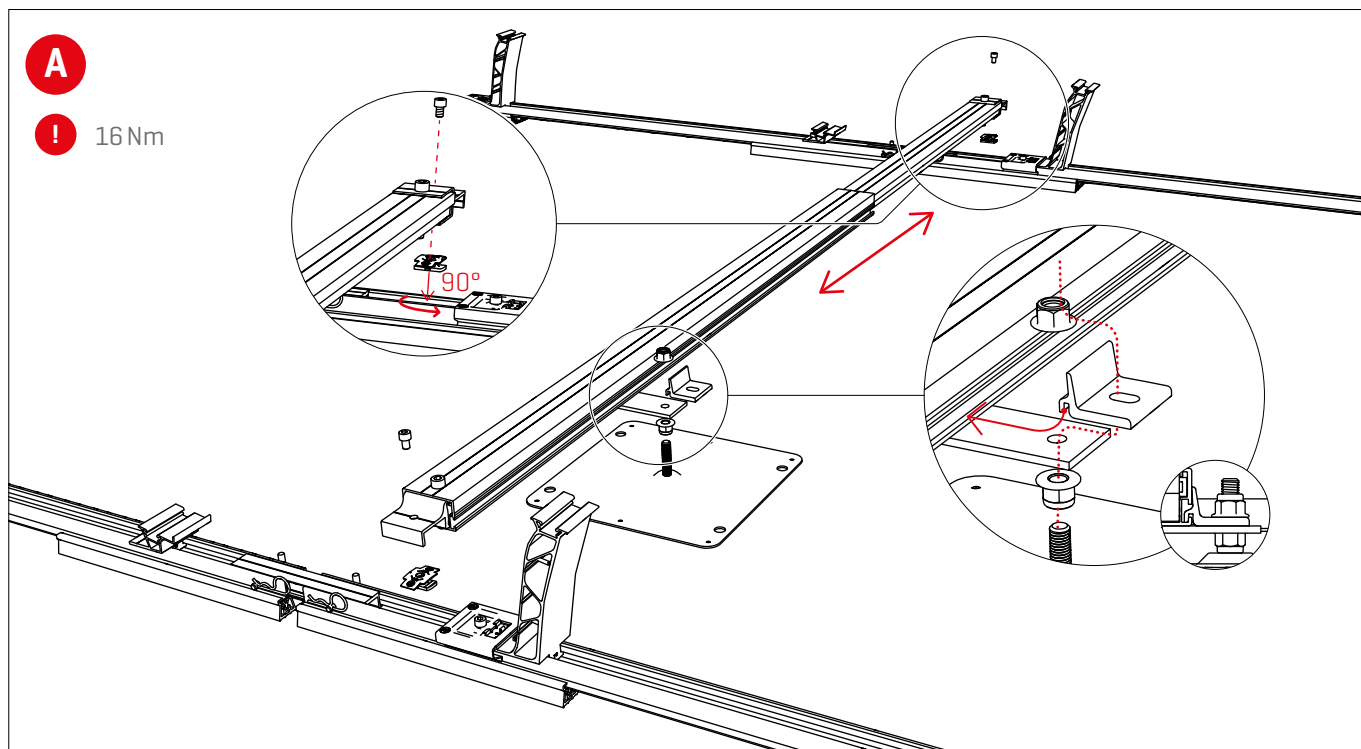

Edge bracing

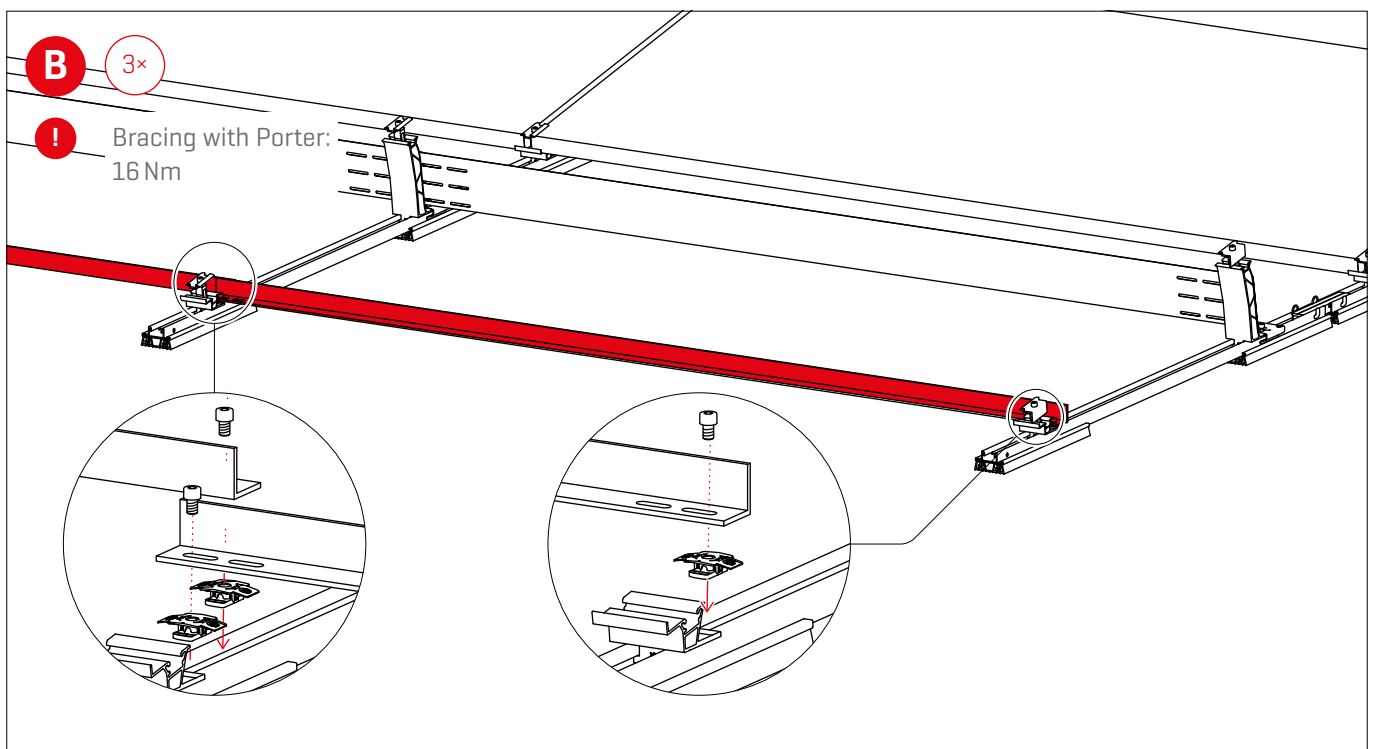
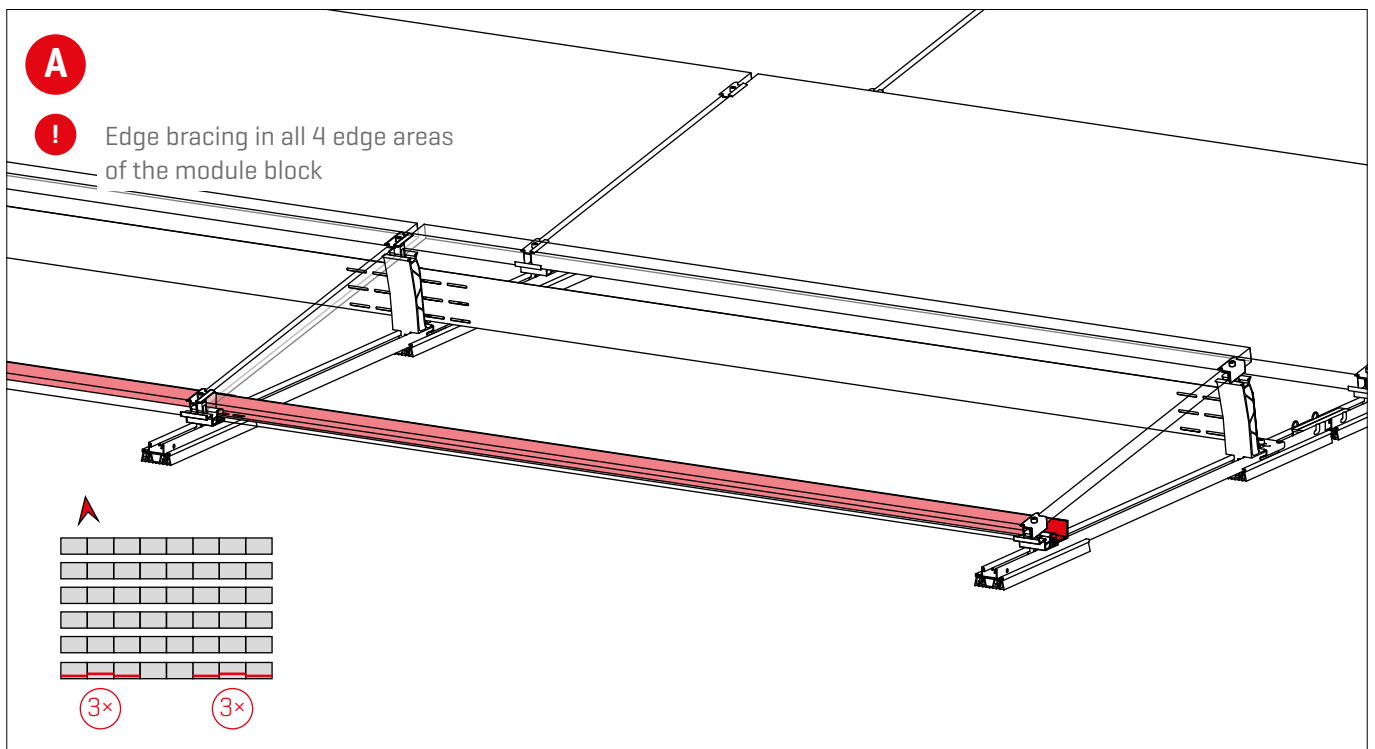

Cable management

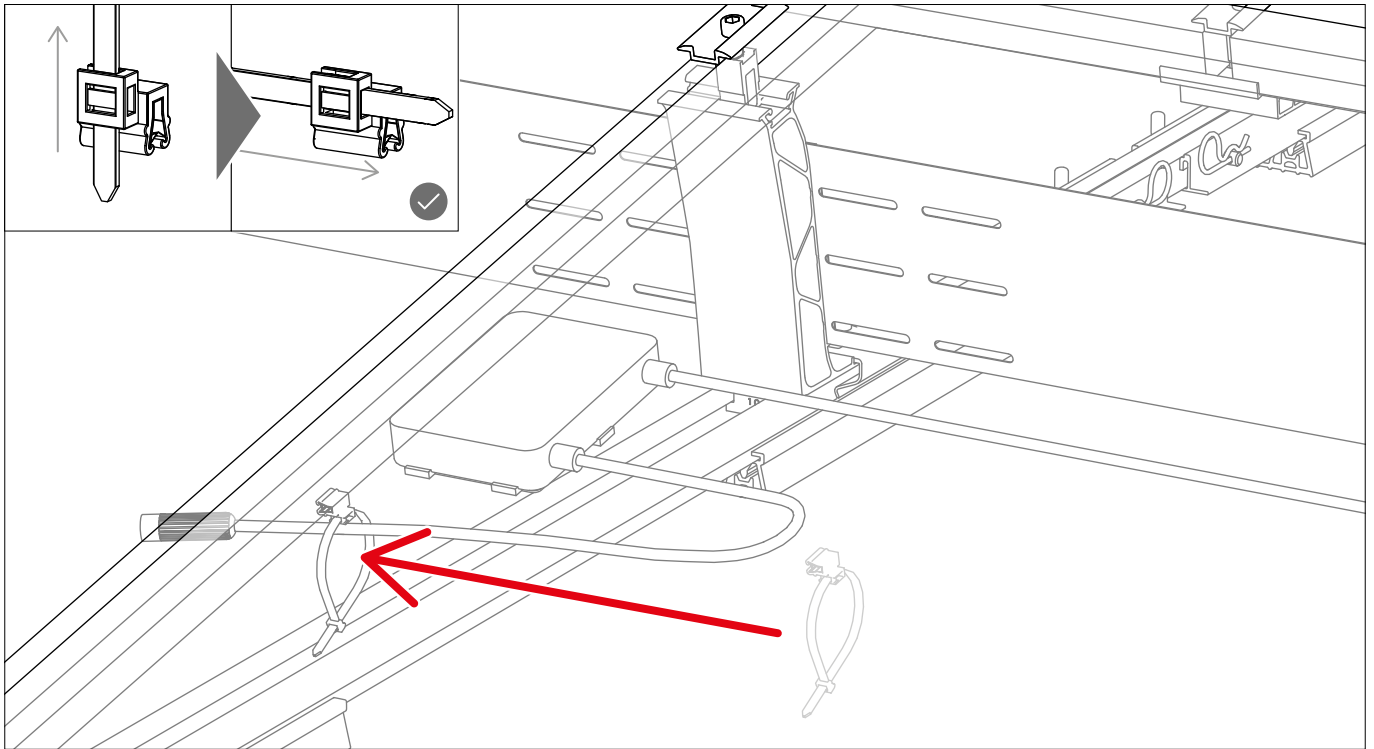

Module frame earthing with TerraGrif

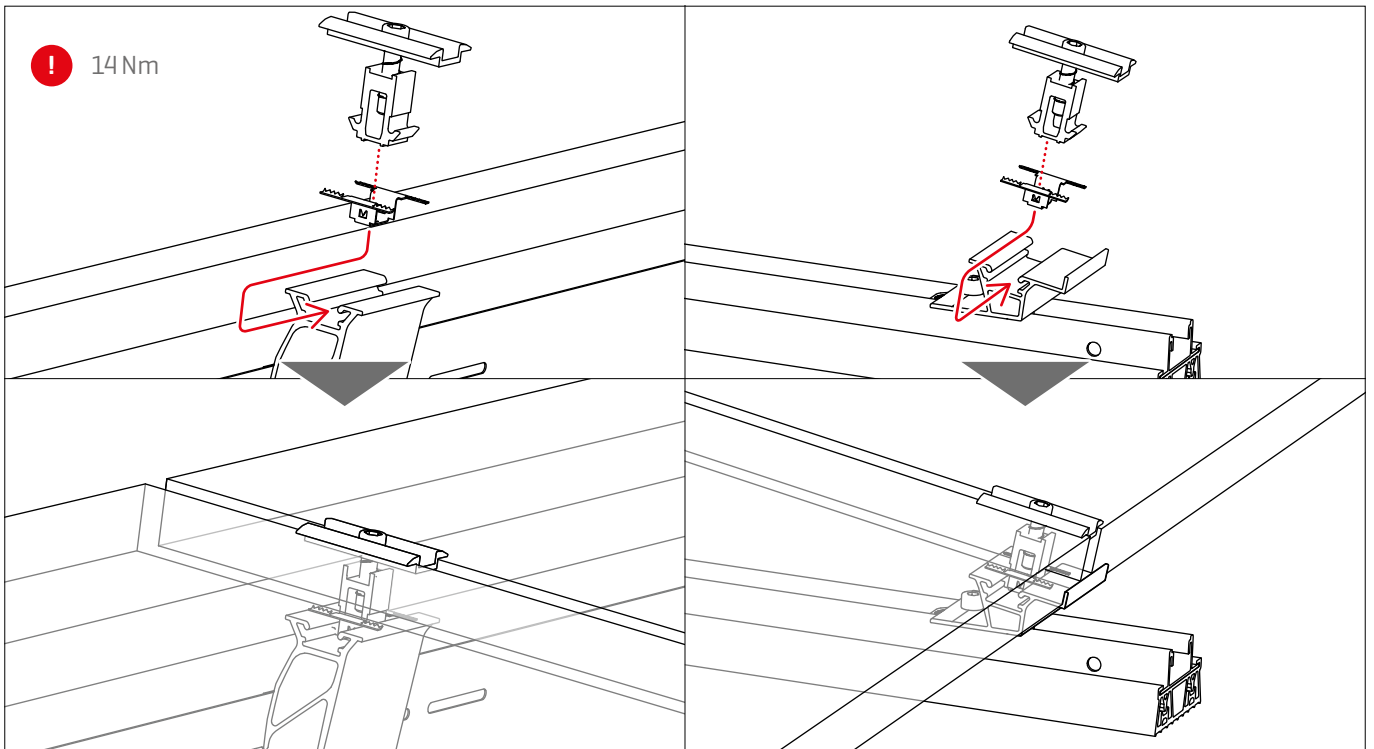

Notes

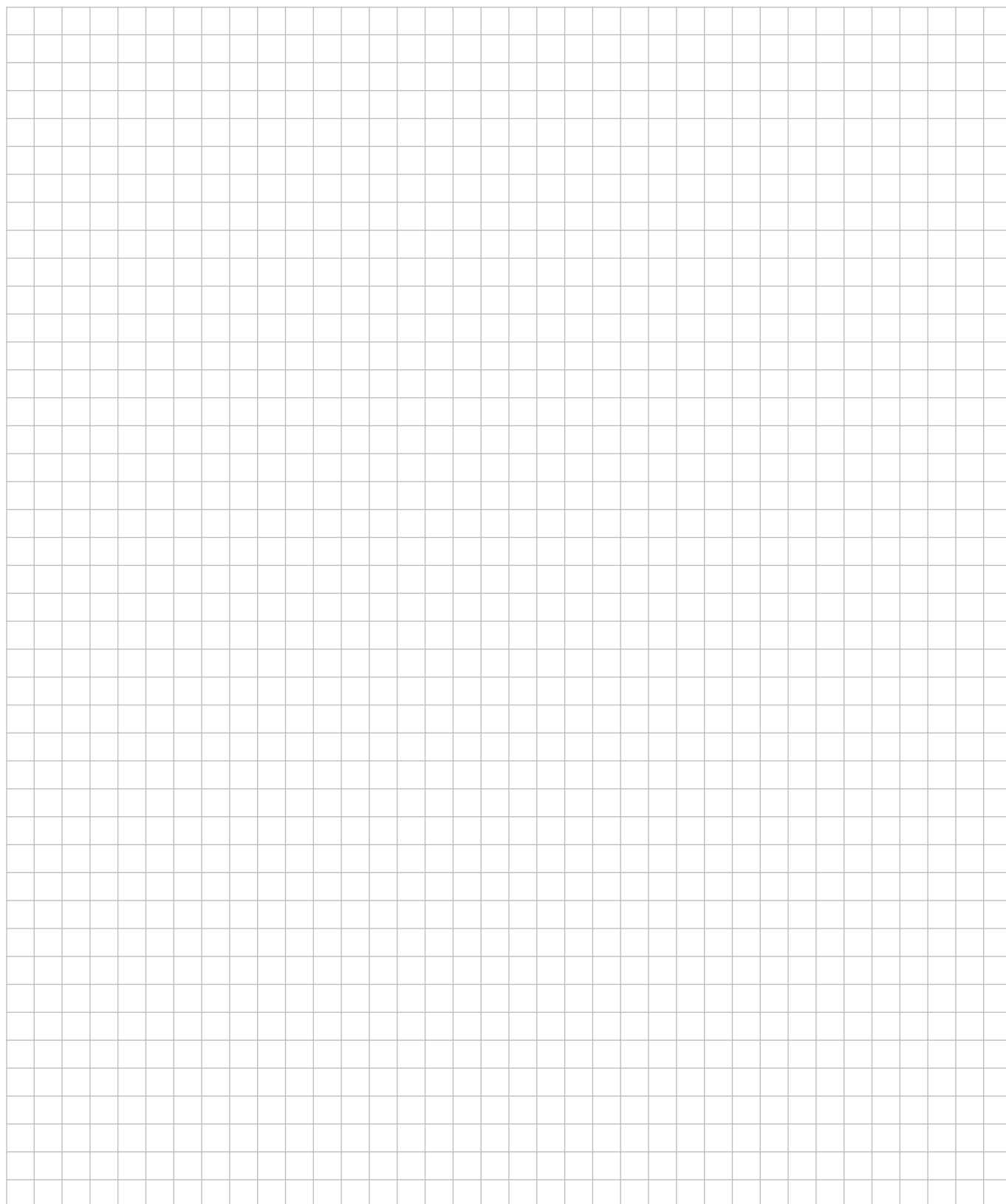



We support PV systems



Thank you for choosing a K2 mounting system.

Systems from K2 Systems are quick and easy to install. We hope these instructions have helped. Please contact us with any questions or suggestions for improvement.

Our contact data:

▶ k2-systems.com/en/contact

▶ **Service Hotline: +49 [0]7159 42059-0**

German law shall apply excluding the UN Convention on CISG. Place of venue is Stuttgart.

Our General Terms of Business apply. Please refer:
k2-systems.com

K2 Systems GmbH

Industriestraße 18
71272 Renningen
Germany

+49 [0] 7159 - 42059 - 0
info@k2-systems.com
www.k2-systems.com