

ASSEMBLY INSTRUCTIONS

P-Rack System



General safety information

Please note that our general mounting instructions must be followed at all times and can be viewed online at

www.k2-systems.com/en/technical-information

- ▶ The equipment may only be installed and operated by qualified and adequately trained installers.
- ▶ Prior to installation, ensure that the product complies with on-site static loading requirements. For roof-mounted systems, the roof load-bearing capacity must always be checked.
- ▶ National and local building regulations and environmental requirements must be adhered to.
- ▶ Compliance with health and safety regulations, accident prevention guidelines and applicable standards is required.
 - Protective equipment such as safety helmet, boots and gloves must be worn.
 - Roofing works must be in accordance with roofing regulations utilising fall protection safeguards when eaves height exceeds 3 m.
 - At least two people must be present for the duration of the installation work in order to provide rapid assistance in the event of an emergency.
- ▶ K2 mounting systems are continuously developed and improved and the installation process may thereby change at any time. Prior to installation consult our website at www.k2-systems.com/en/technical-information for up-to-date instructions. We can send you the latest version on request.
- ▶ The assembly instructions of the module manufacturer must be adhered to.
- ▶ Equipotential bonding/grounding/earthing between individual parts is to be performed according to country specific standards, as well as national laws and regulations.
- ▶ At least one copy of the assembly instructions should be available on site throughout the duration of the installation.
- ▶ Failure to adhere to our general safety and assembly instructions and not using all system components, K2 is not liable for any resulting defects or damages. We do not accept liability for any damage resulting in the use of competitor's parts. Warranty is excluded in such cases.
- ▶ German law shall apply excluding the UN Convention on CISG. Place of venue is Stuttgart. Our General Terms of Business apply.
- ▶ If all safety instructions are adhered to and the system is correctly installed, there is a product warranty entitlement of 12 years! We strongly recommend reviewing our terms of guarantee, which can be viewed at www.k2-systems.com/en/technical-information. We will also send this information on request.
- ▶ Dismantling of the system is performed in reverse order to the assembly.
- ▶ K2 stainless steel components are available in different corrosion resistance classes. Each structure or component must be carefully checked for possible corrosion exposure.

The following guidelines apply

The P-Rack system can be used without further testing by K2 Systems in the following standard conditions. The system is also suitable for higher requirements. However, if a value exceeds the standard conditions, please contact K2 Systems.



GROUND REQUIREMENTS

The following soil properties were assumed:

- ▶ $\phi = 25^\circ$ (slide friction angle)
- ▶ $\sigma_{R,d} = 130 \text{ kN/m}^2$ (soil pressure resistance)
- ▶ $\gamma = 16 \text{ kN/m}^3$ (unit weight earth-moist)
- ▶ $\gamma_a = 6 \text{ kN/m}^3$ (unit weight below groundwater table)

A sufficient capacity of the soil needs to be checked in the specific project by the constructor/owner of the site.



STRUCTURAL REQUIREMENTS

- ▶ Peak velocity pressure $q_p(z)$ up to:
 - 0.8 kN/m^2 (Set 2002714)
 - 1.3 kN/m^2 (Set 2002781)
- ▶ Ground snow load s_k of up to:
 - 0.8 kN/m^2 (Set 2002714)
 - 1.3 kN/m^2 (Set 2002781)



IMPORTANT MOUNTING INSTRUCTIONS

- ▶ On-site general standards and regulations for lightning protection must be observed and consultation with a specialist to create a lightning protection concept is recommended (use lightning protection clamp if necessary).
- ▶ Adhere to module manufacturer recommendations for clamping area and module installation (see module manufacturer instructions).
- ▶ Tightening torque
 - M8 screws: 14 Nm
 - M10 screws: 30 Nm
 - Multi Monti: 90 Nm
- ▶ Module sizes: 1580 - 1650 × 980 - 1005 mm
- ▶ Module frame heights: 32 - 42 mm (other module clamps available)

Tools

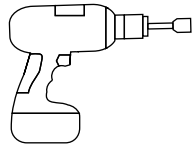

8/17/21 mm

8 mm

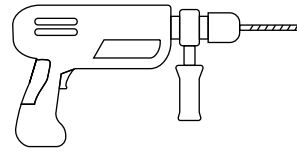

Ø 12 mm
L ≥ 120 mm



10-100 Nm
(7.4-73.8 lb-ft)



8/17/21 mm

8 mm

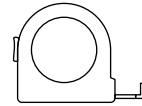

≥ 3,0 m



≥ 6,0 m

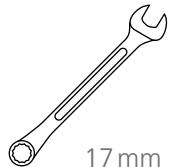

17 mm

Components



! 56x 80x

Set 2002714 3x support 0.8 kN/m²
 Set 2002781 5x support 1.3 kN/m²

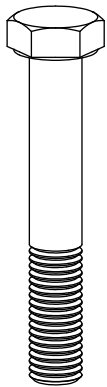

2002410
Hexagon bolt
M10x60
42x 70x

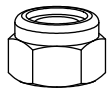

1002849
Self-locking
hexagon nut M10
42x 70x

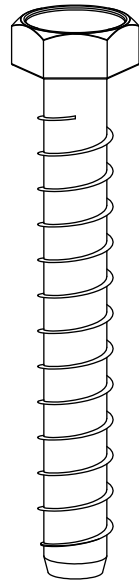

2002627
Multi Monti
14x110
6x 10x

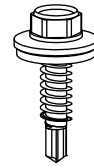

1001051
Self-tapping screw
5.5x25
40x 40x

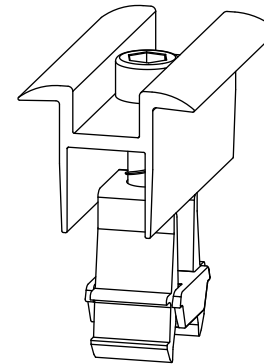

2002515
OneMid
32-42 mm
28x 28x

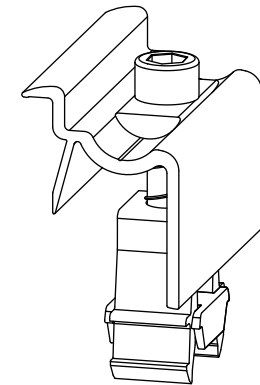

2002514
OneEnd
32-42 mm
8x 8x

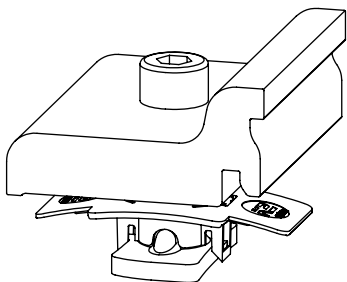

2001626
Climber 63 Set
12x 20x

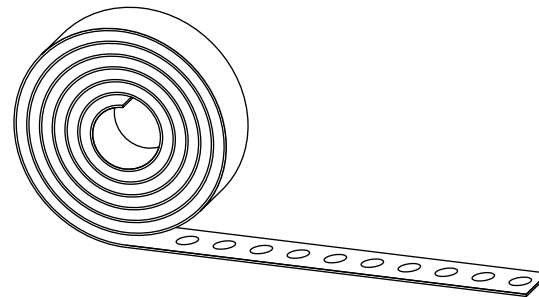

2002735
Perforated tape
10m 10m

!

| | |
|-----|-----|
| 56x | 80x |
|-----|-----|

Set 2002714
3x support
0.8 kN/m²

Set 2002781
5x support
1.3 kN/m²

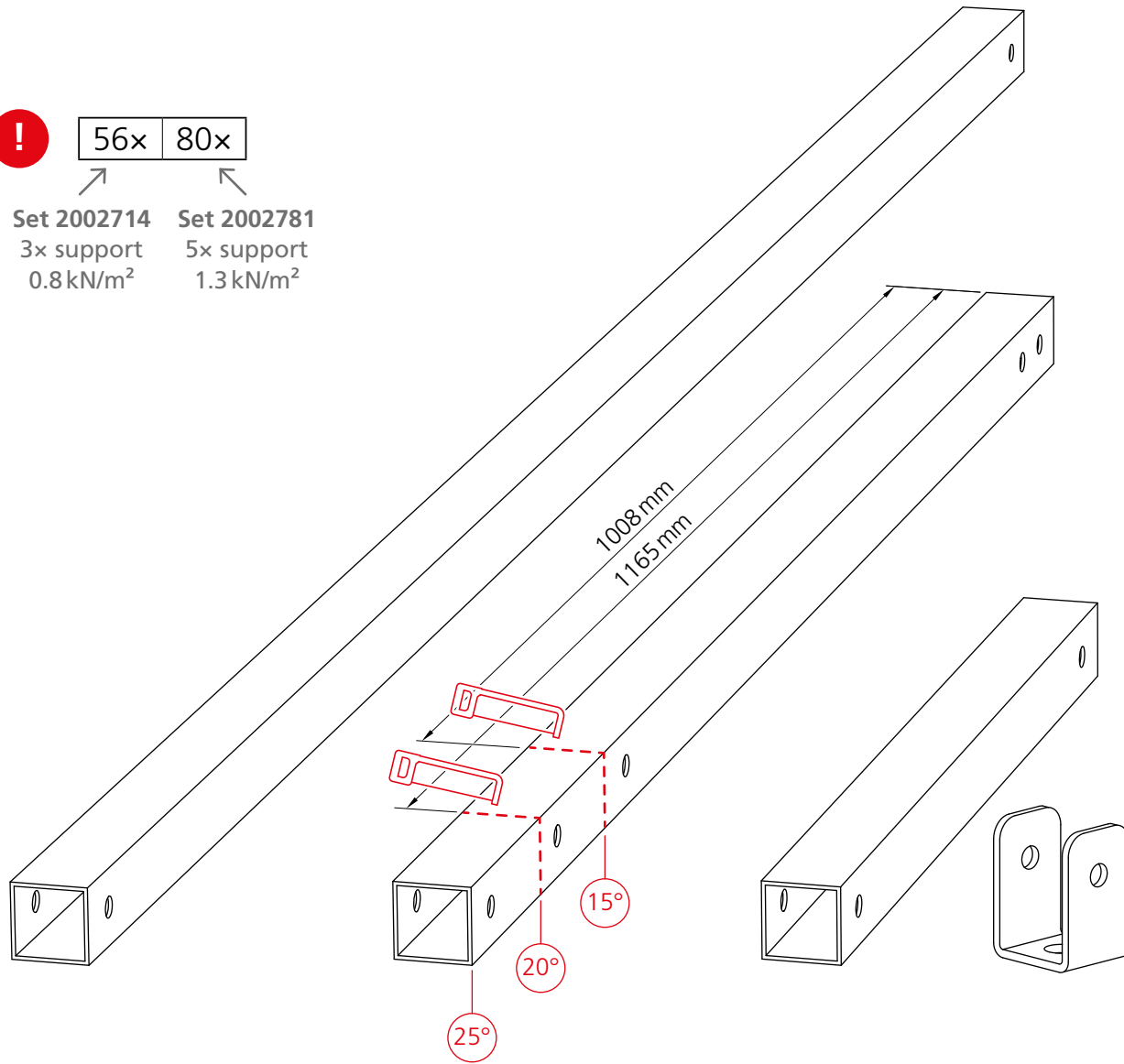

2002598
Cross-Tie Middle

| | |
|----|----|
| 3x | 5x |
|----|----|

2002597
Cross-Tie
· 25° no sawing
· 20° sawing at 1165 mm
· 15° sawing at 1008 mm

| | |
|----|----|
| 3x | 5x |
|----|----|

2002594
Cross-Tie Front

| | |
|----|----|
| 3x | 5x |
|----|----|

2002603
Foot Front

| | |
|----|----|
| 3x | 5x |
|----|----|

2002604
Foot End

| | |
|----|----|
| 3x | 5x |
|----|----|

2002605
Gusset plate

| | |
|----|-----|
| 6x | 10x |
|----|-----|

2002599
Connector
Cross-Tie

| | |
|----|-----|
| 6x | 10x |
|----|-----|



| | |
|-----|-----|
| 56x | 80x |
|-----|-----|



Set 2002714
3x support
0.8 kN/m²

Set 2002781
5x support
1.3 kN/m²

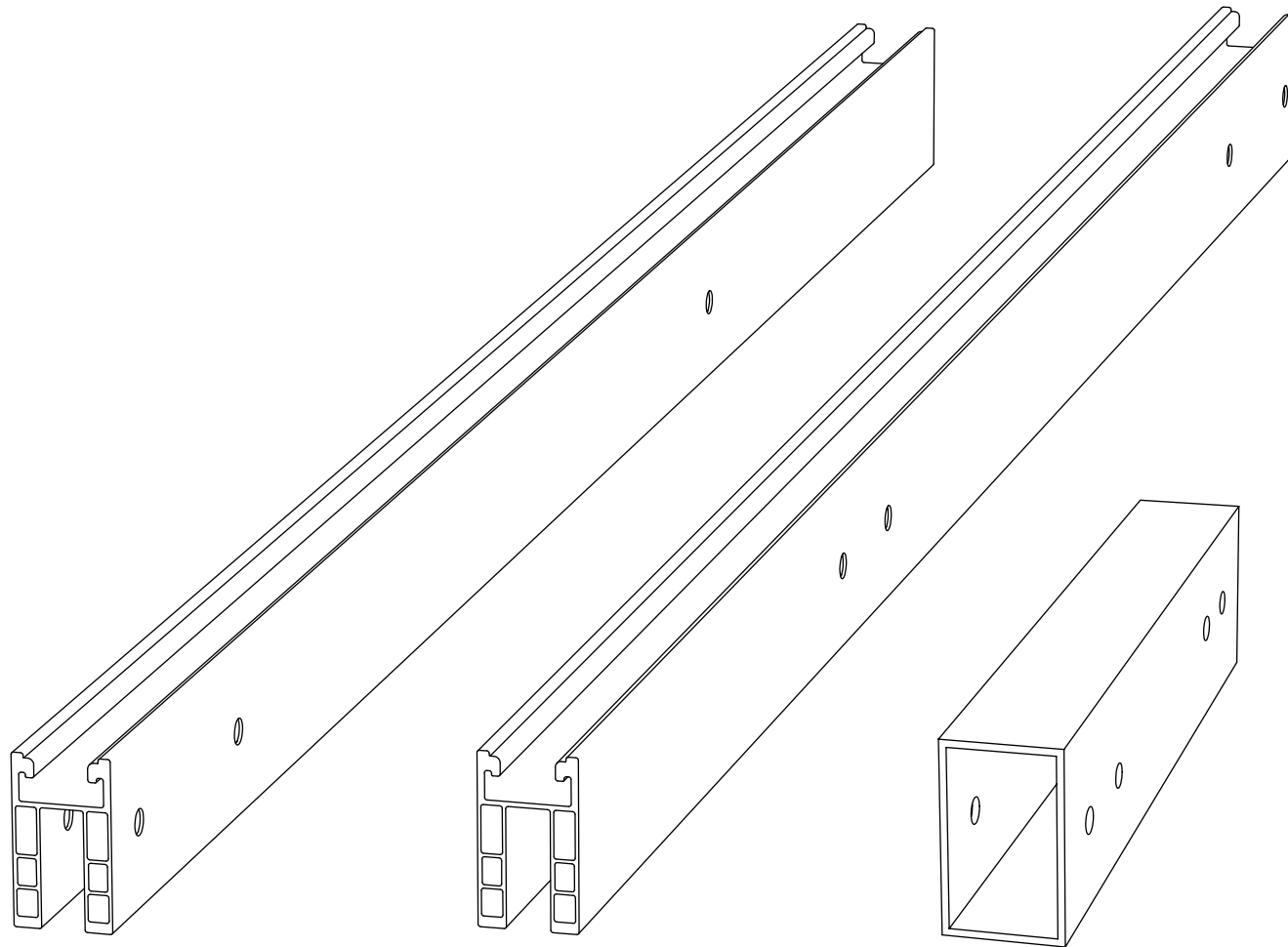

2002584
CrossBar 3.0

| | |
|----|----|
| 3x | 5x |
|----|----|

2002585
CrossBar 3.0 Front

| | |
|----|----|
| 3x | 5x |
|----|----|

2002516
Rail Connector
CrossBar 3.0

| | |
|----|----|
| 3x | 5x |
|----|----|

!

| | |
|-----|-----|
| 56x | 80x |
|-----|-----|

Set 2002714 **Set 2002781**
 3x support 5x support
 0.8 kN/m² 1.3 kN/m²

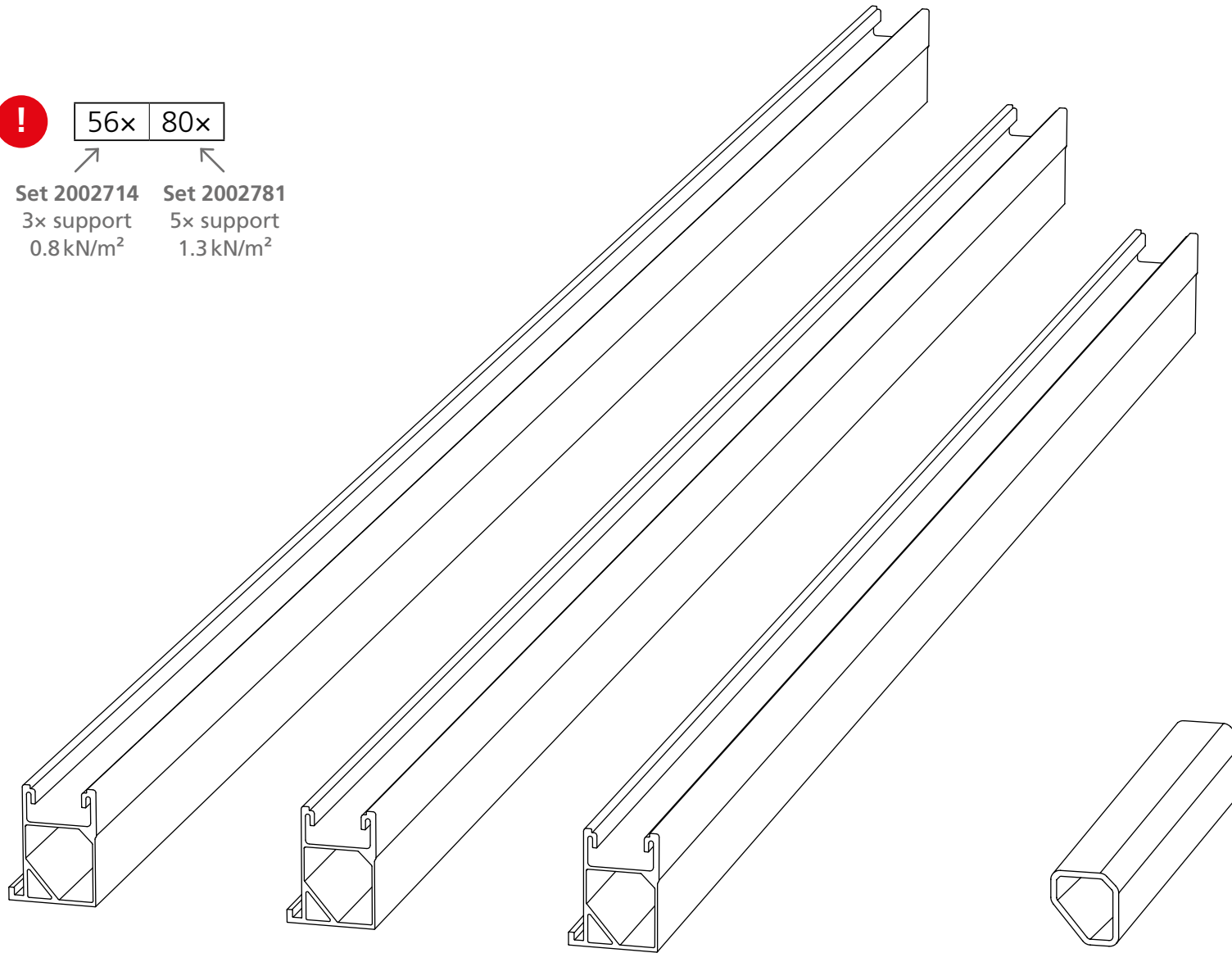

2002580 | 2002784
 SingleRail 63;
 1.90 m | 2.00 m

| | |
|----|----|
| 8x | 8x |
|----|----|

2002579 | 2002785
 SingleRail 63;
 1.60 m | 1.72 m

| | |
|----|----|
| 8x | 8x |
|----|----|

2002578 | 2002786
 SingleRail 63;
 1.30 m | 0.87 m

| | |
|----|----|
| 4x | 4x |
|----|----|

2001297
 Rail Connector
 SingleRail 63

| | |
|-----|-----|
| 16x | 16x |
|-----|-----|

Assembly

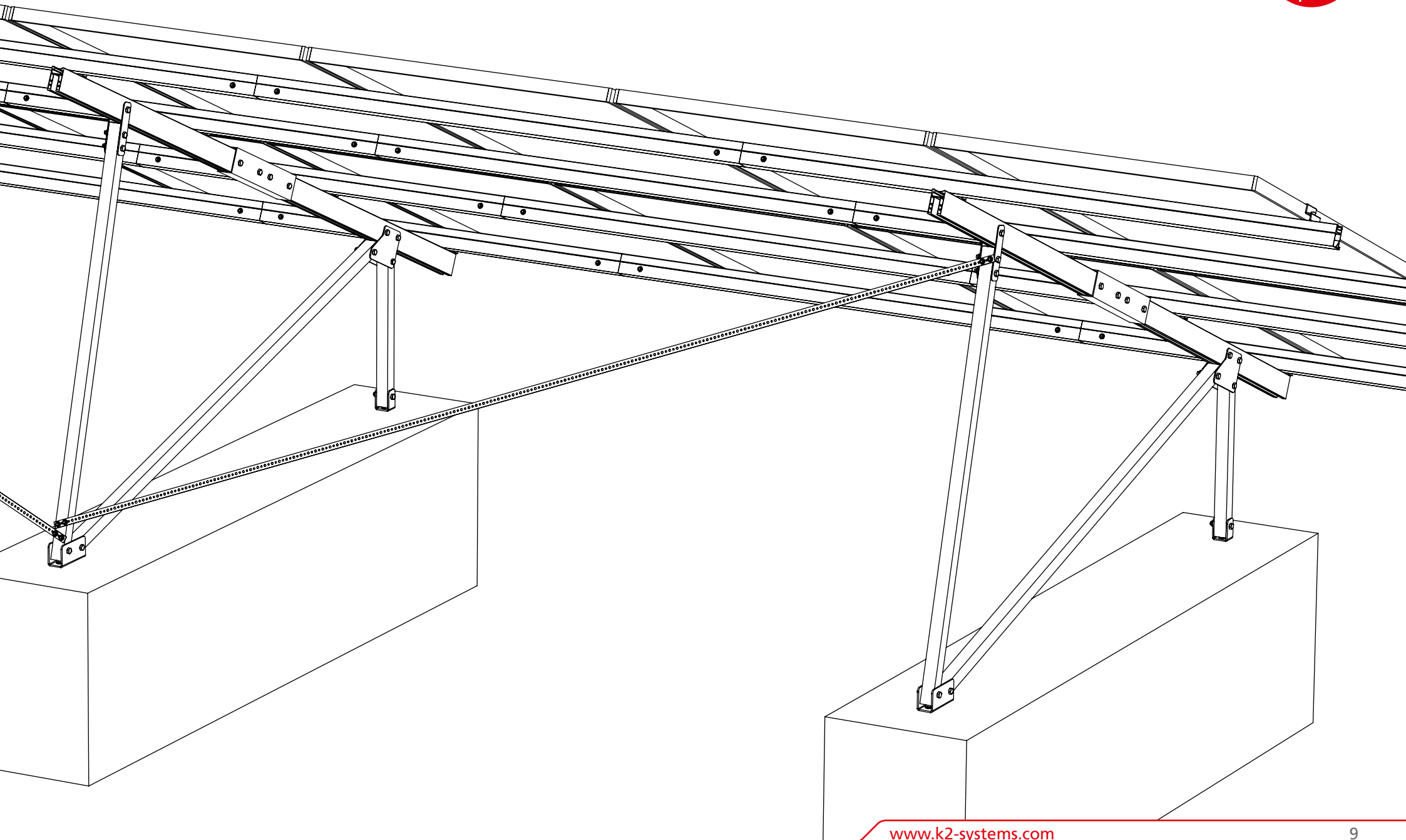

1

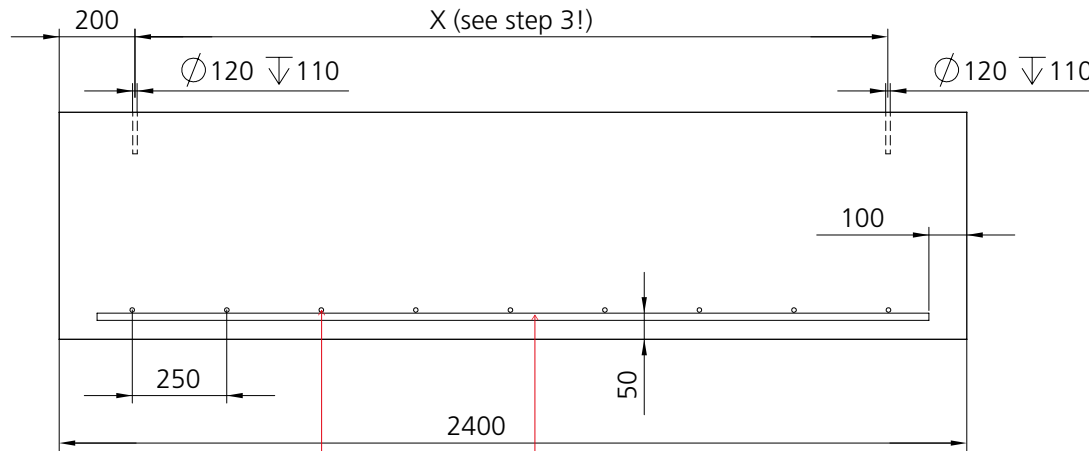
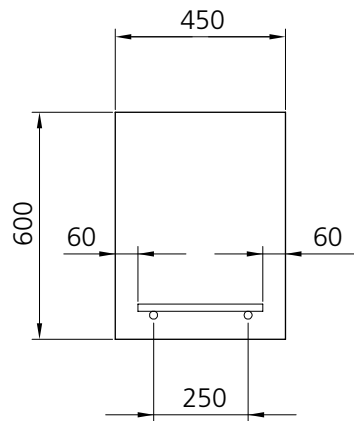

Dimensions in millimetre [mm]!

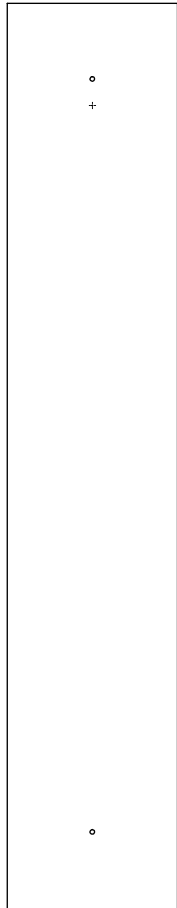

2 2x Ø 12 e=25

1 9x Ø 12 e=25

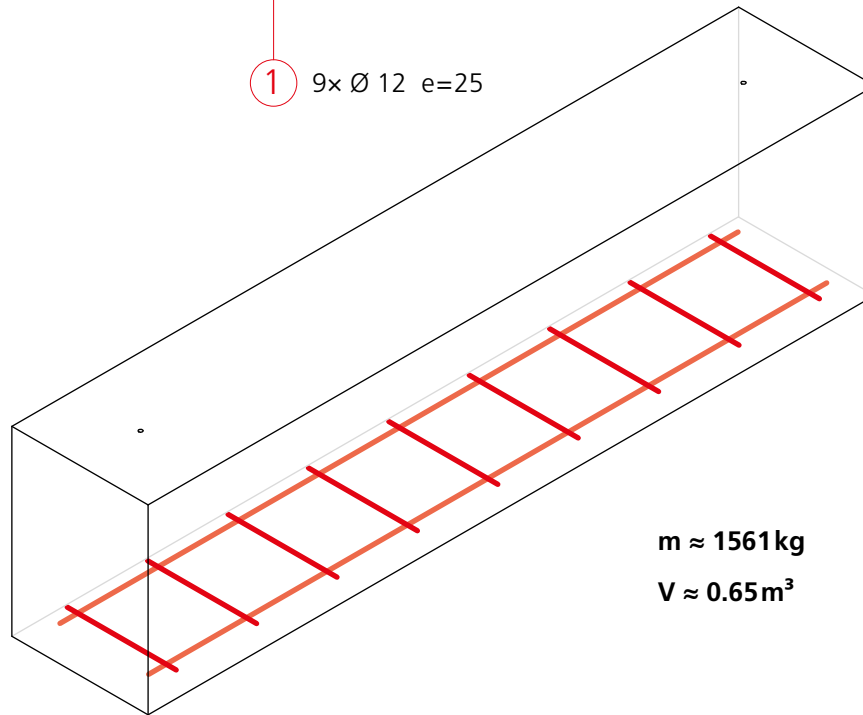

$m \approx 1561 \text{ kg}$
 $V \approx 0.65 \text{ m}^3$

Construction steel EN10025

| Position | Amount | Ø | Length |
|----------|--------|----|--------|
| 1 | 9 | 12 | 0.33m |
| 2 | 2 | 12 | 2.20m |

$\Sigma = 7.37 \text{ m (6.55 kg)}$

2

A 3x support · 0.8 kN/m² wind/snow load

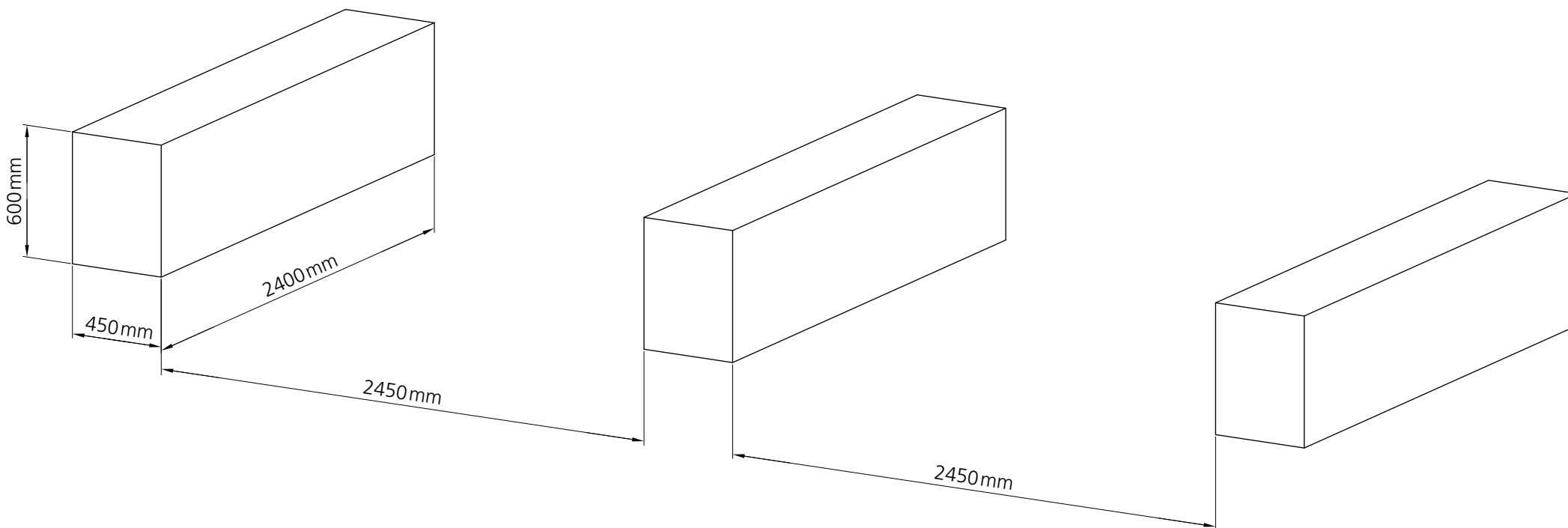

2

B 5x support · 1.3 kN/m² wind/snow load

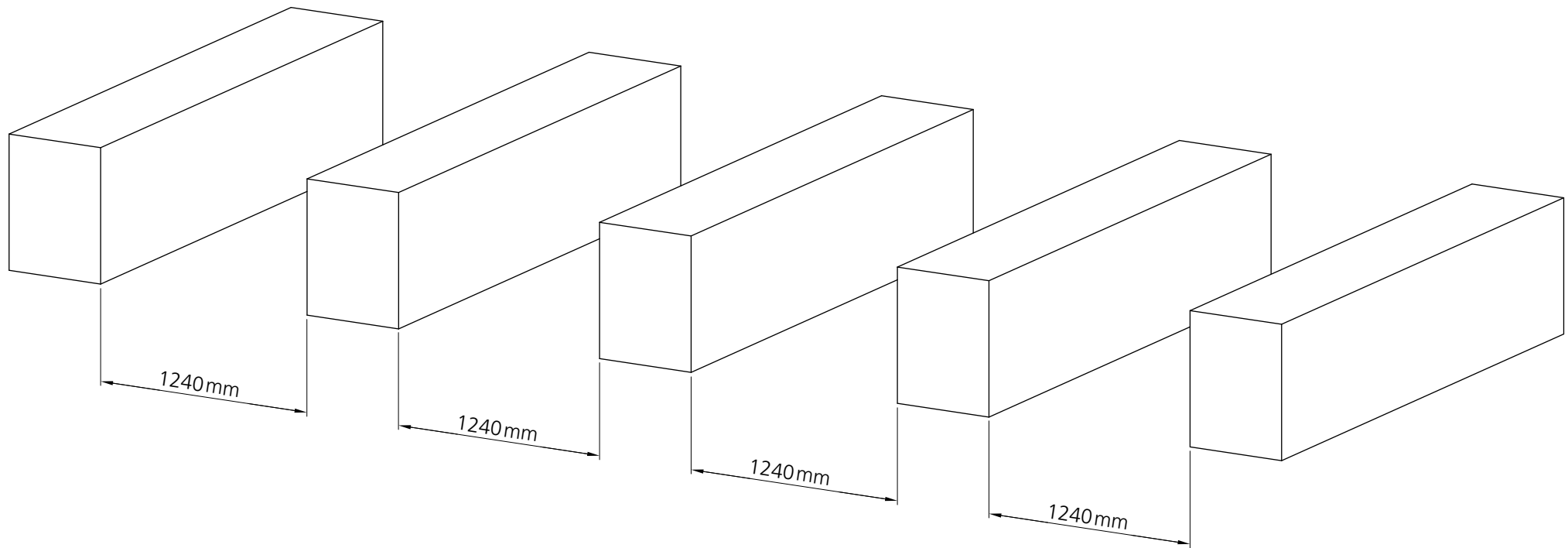

3

A 3x support · 0.8 kN/m² wind/snow load

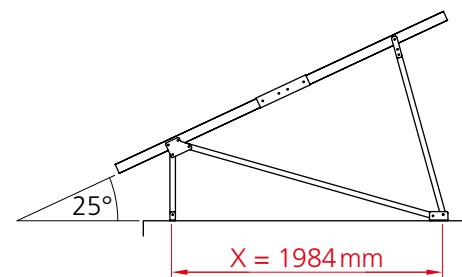
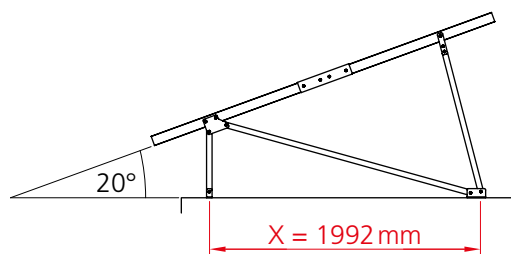
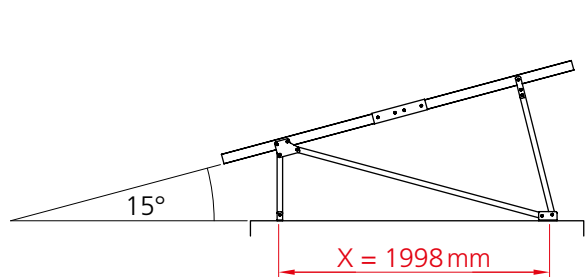
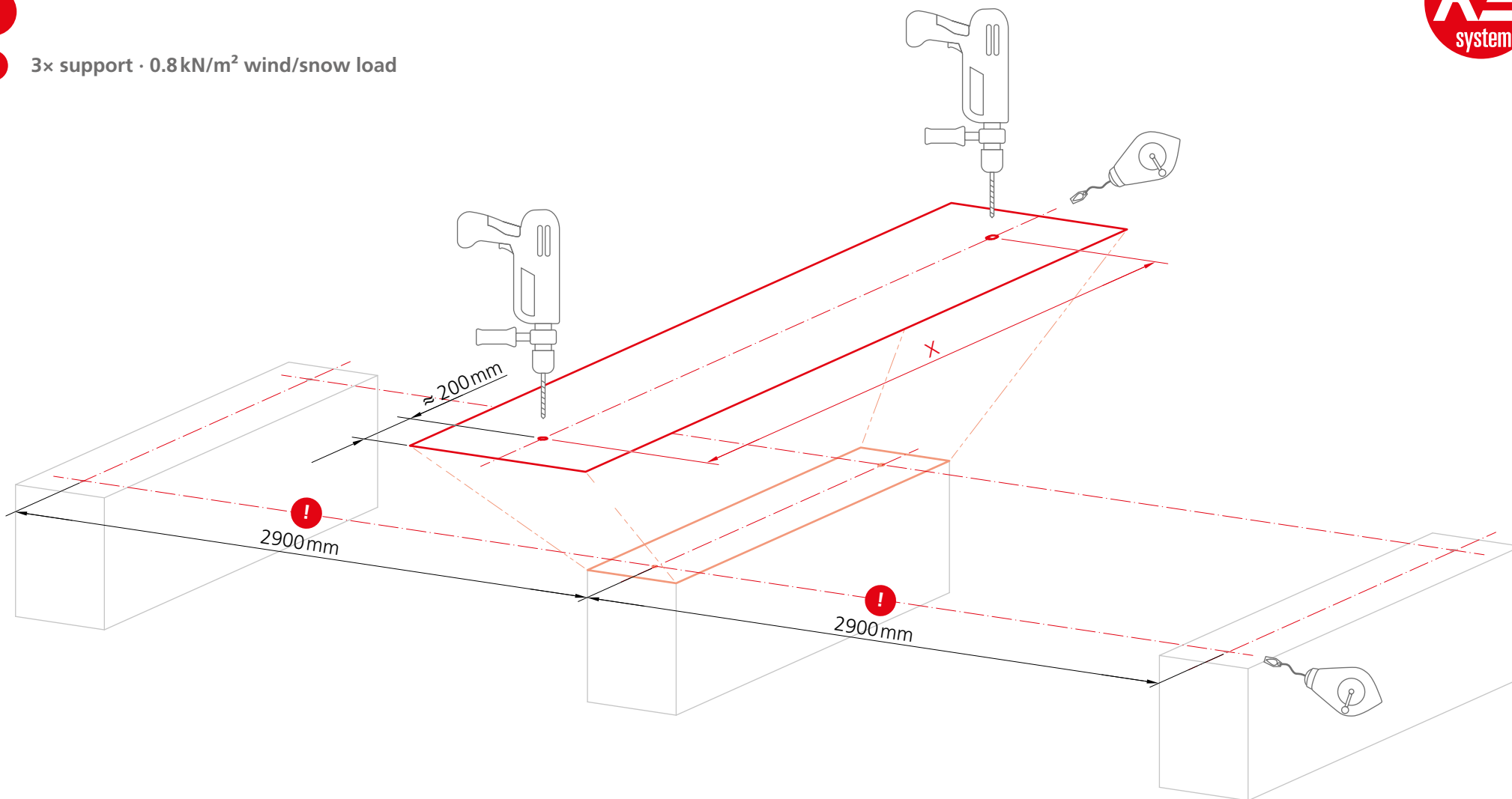

3

B 5x support · 1.3 kN/m² wind/snow load

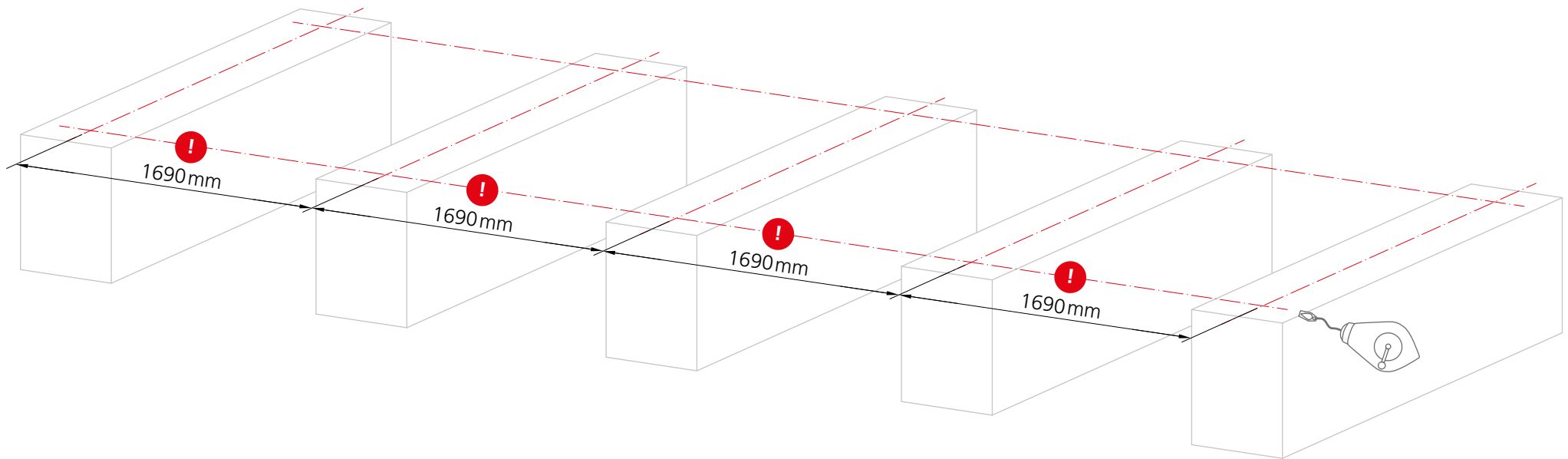

4

! A+B: Torque = 90Nm! 



- ▶ 1x 2002627
- ▶ 1x 2002604

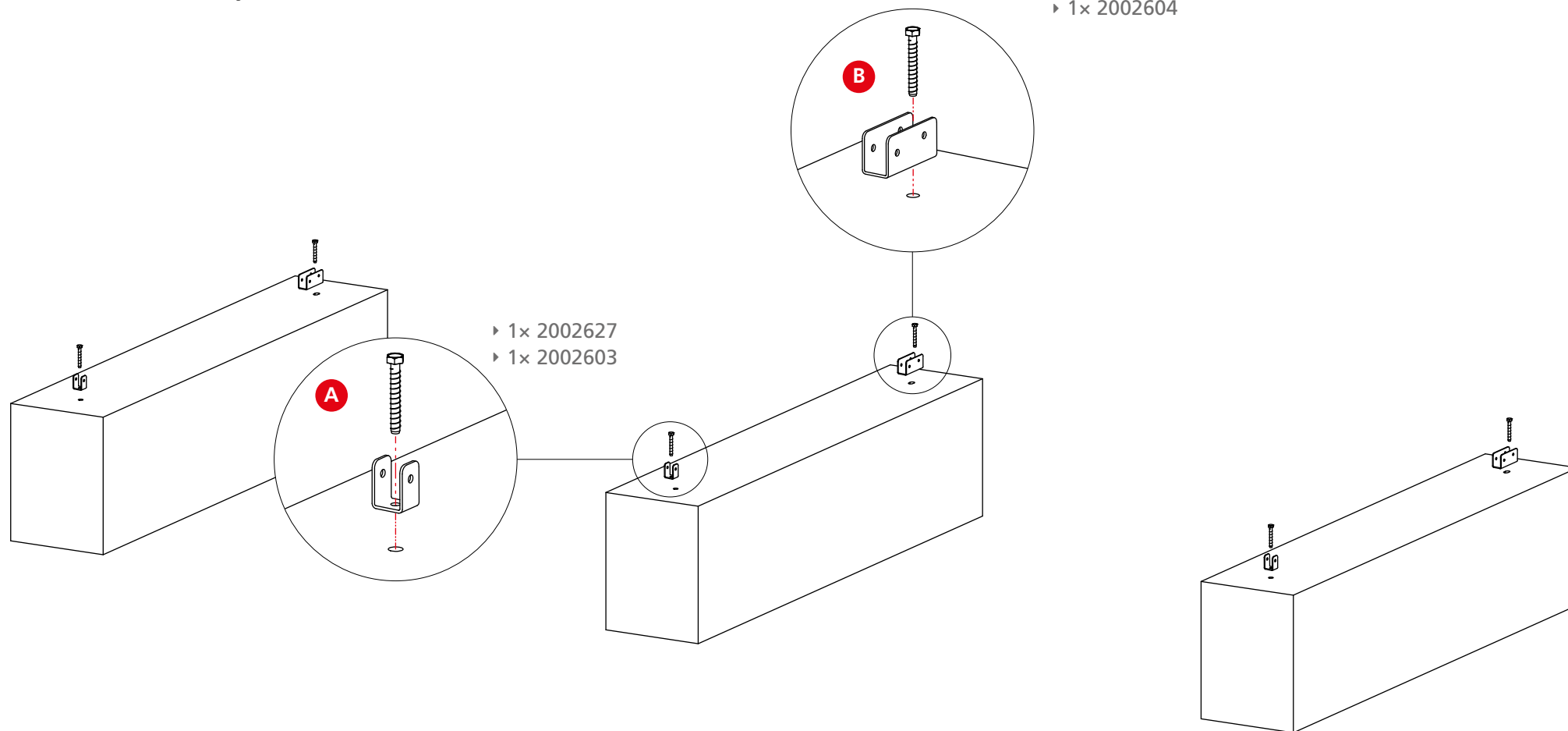

5 3x 5x

! A-D: Torque = 30Nm!

- ▶ 1x 2002585
- ▶ 1x 2002584
- ▶ 1x 2002516
- ▶ 4x 2002410
- ▶ 4x 1002849

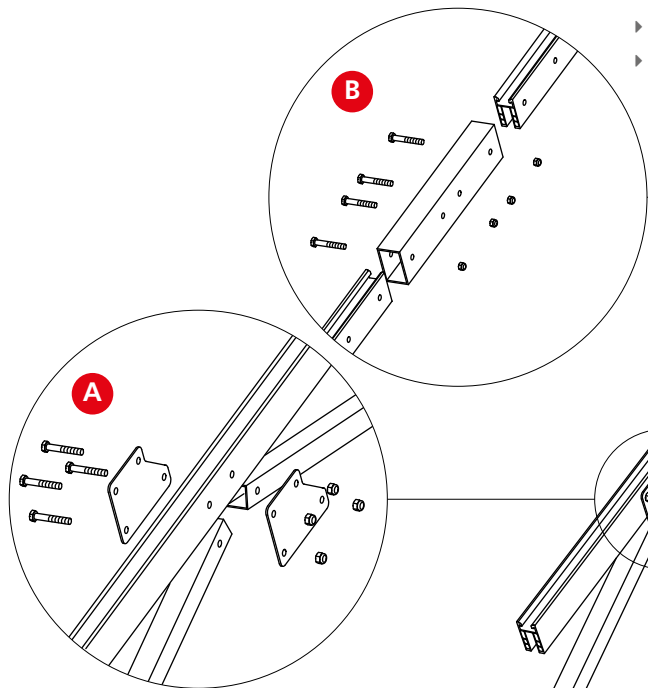

- ▶ 1x 2002585
- ▶ 1x 2002594
- ▶ 1x 2002598
- ▶ 4x 2002410
- ▶ 4x 1002849
- ▶ 2x 2002605

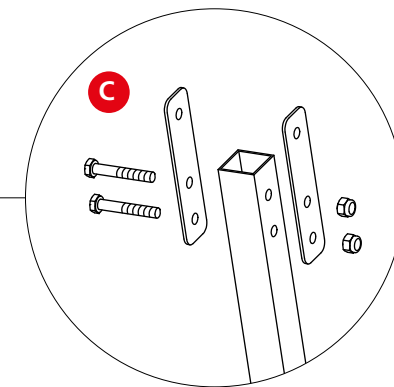
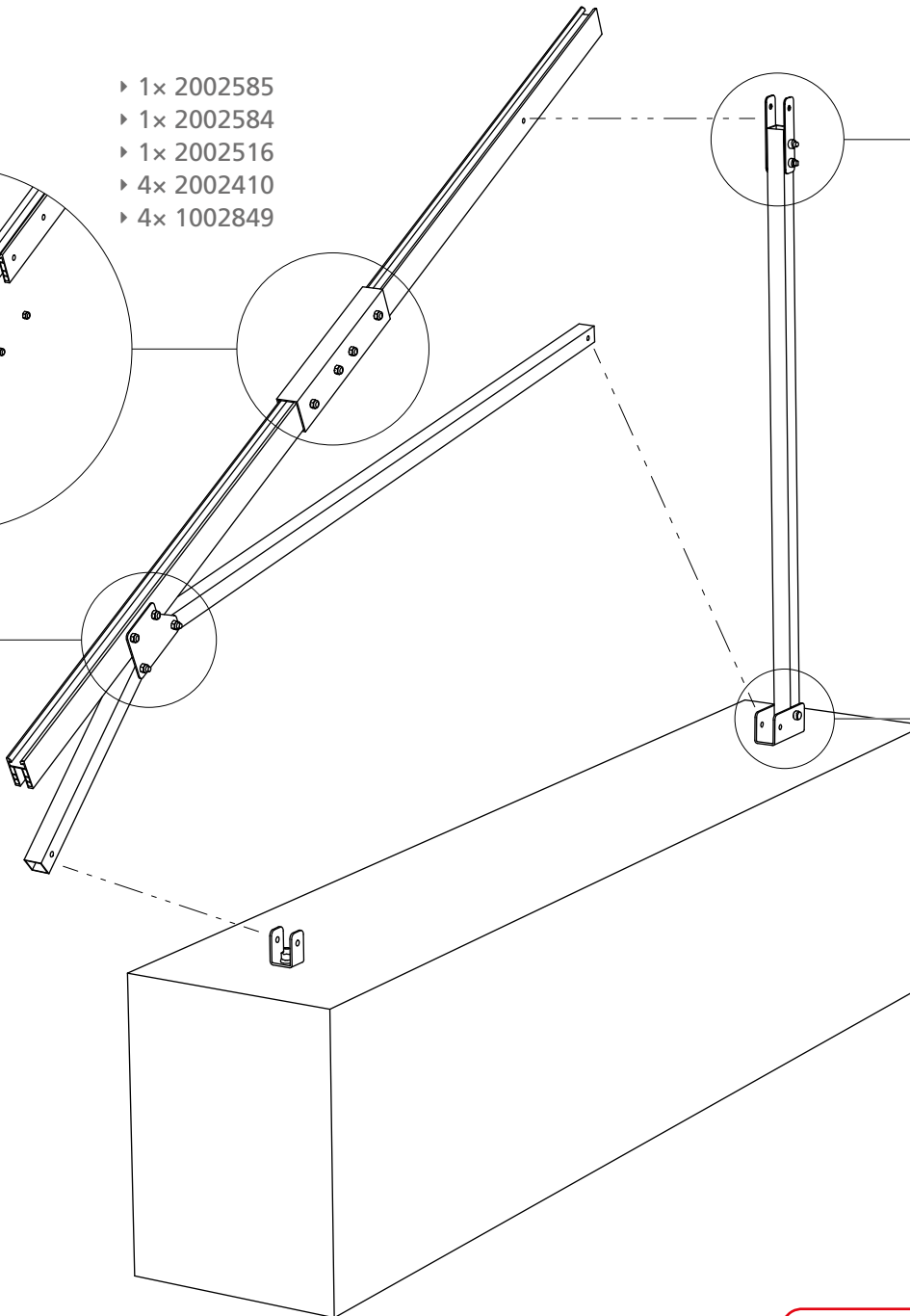
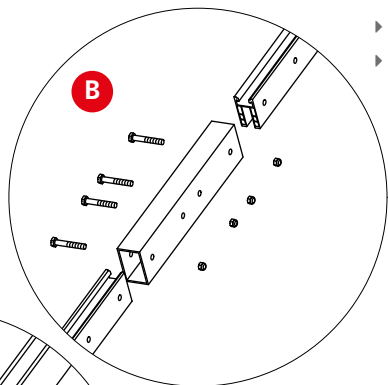

- ▶ 1x 2002597 (15/20/25°)
- ▶ 2x 2002599
- ▶ 2x 2002410
- ▶ 2x 1002849

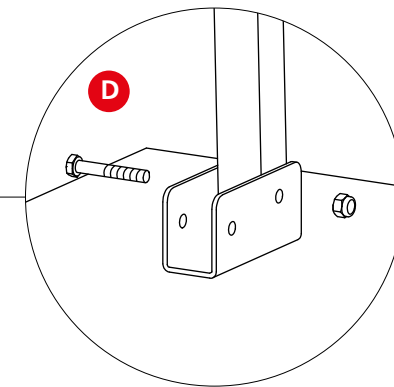

- ▶ 1x 2002597 (15/20/25°)
- ▶ 1x 2002604
- ▶ 1x 2002410
- ▶ 1x 1002849



6 3x 5x

! A-C: Torque = 30Nm! 

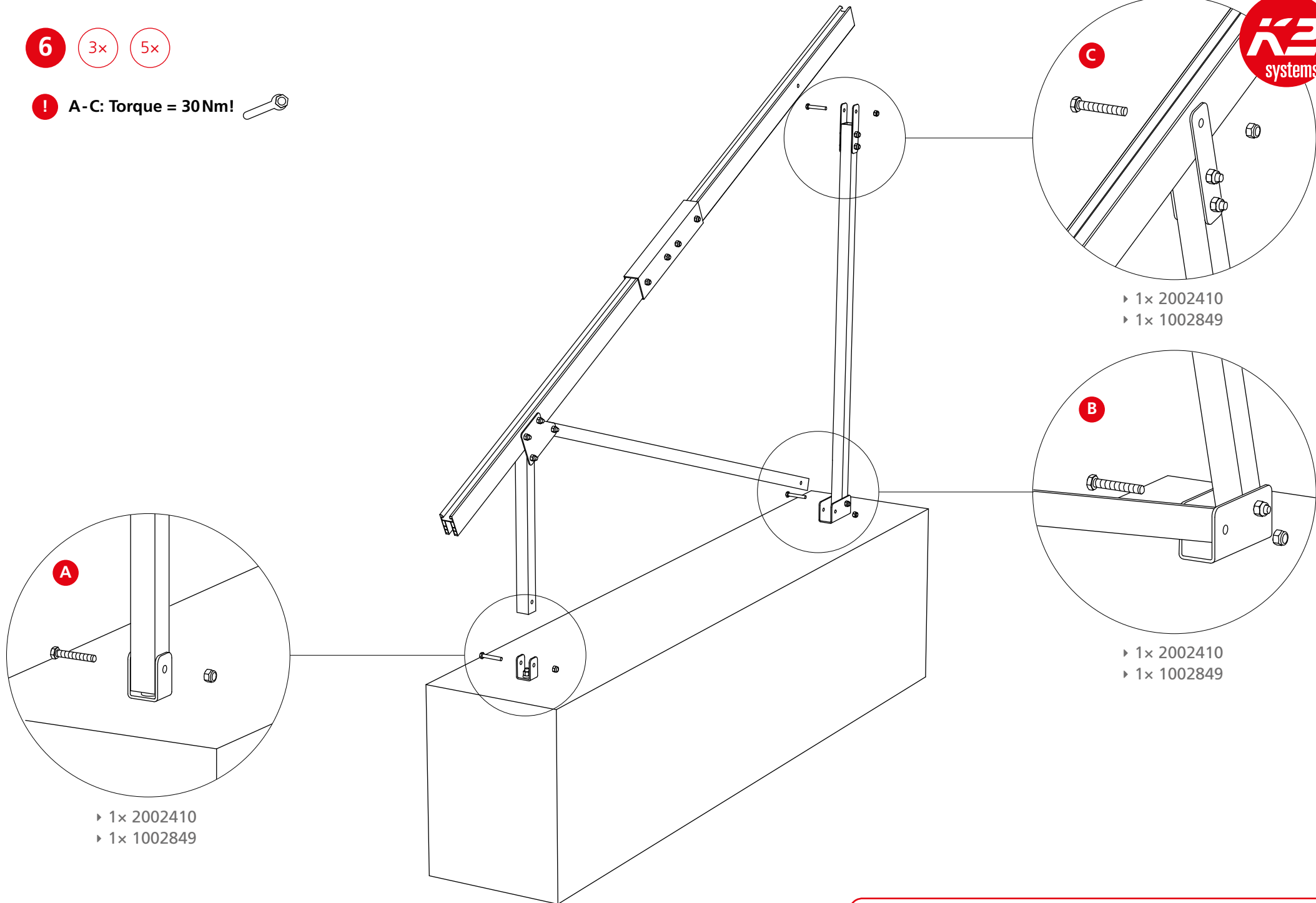

A

- ▶ 1x 2002410
- ▶ 1x 1002849

B

- ▶ 1x 2002410
- ▶ 1x 1002849

C

- ▶ 1x 2002410
- ▶ 1x 1002849

7

4x

- ▶ 1x 2002580/2002784
- ▶ 1x 2002579/2002795
- ▶ 1x 2001297
- ▶ 2x 1001051

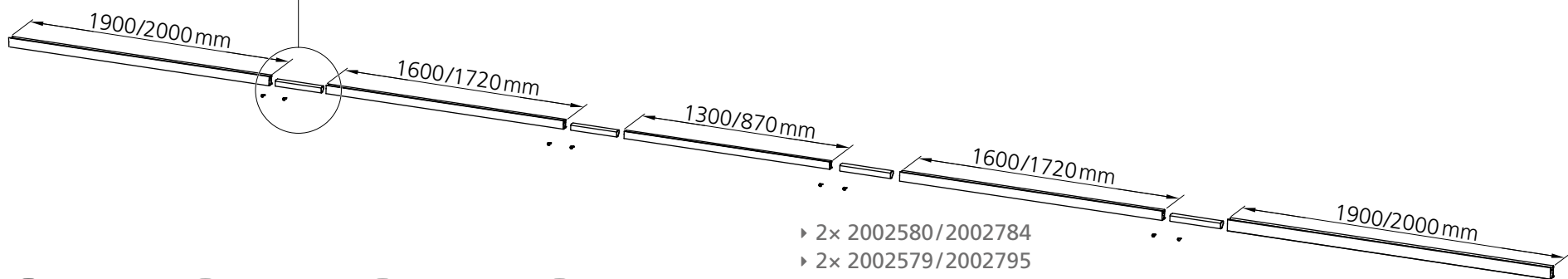
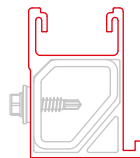
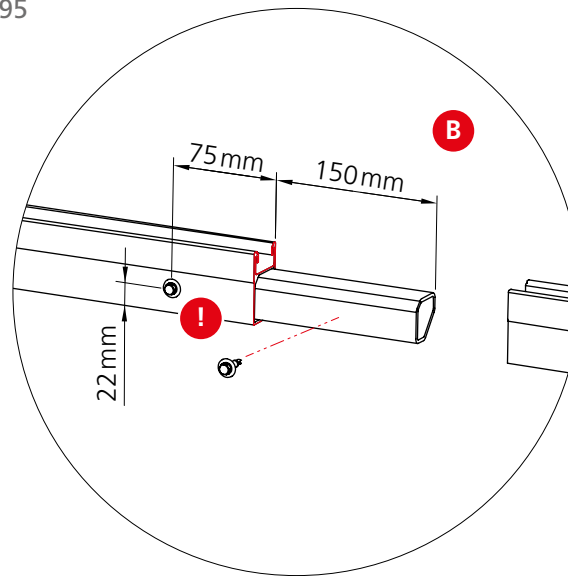
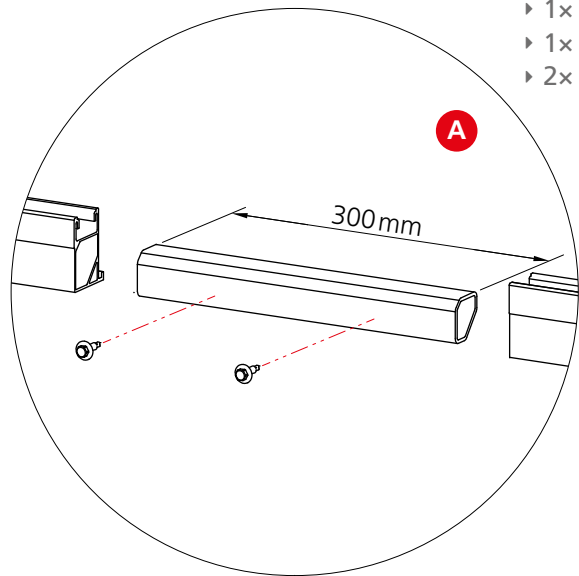

- ▶ 2x 2002580/2002784
- ▶ 2x 2002579/2002795
- ▶ 1x 2002578/2002796
- ▶ 4x 2001297
- ▶ 8x 1001051

!

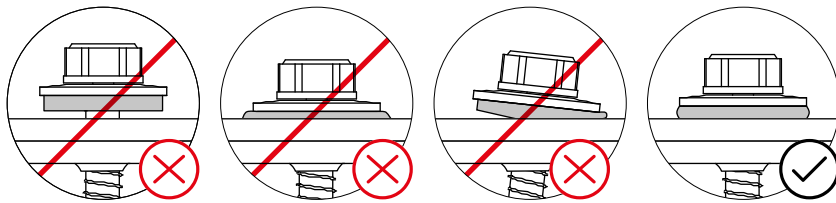

8

! Torque = 14Nm!

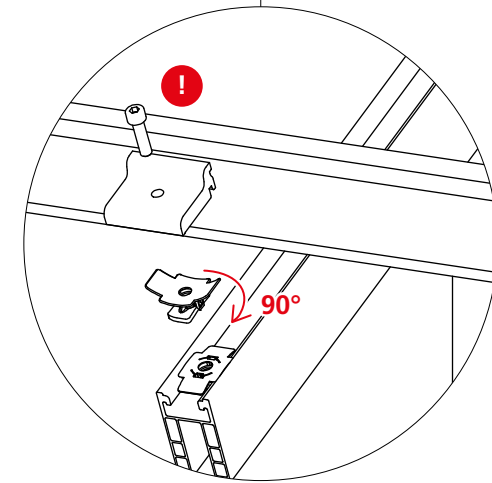
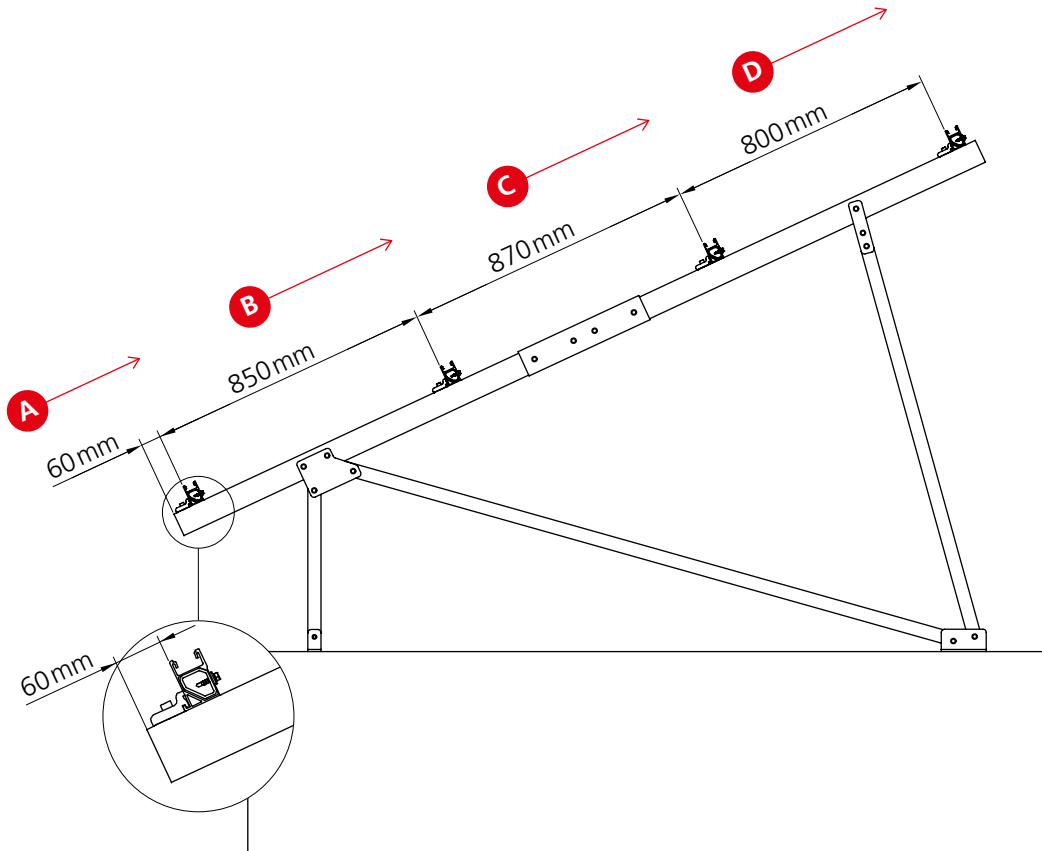
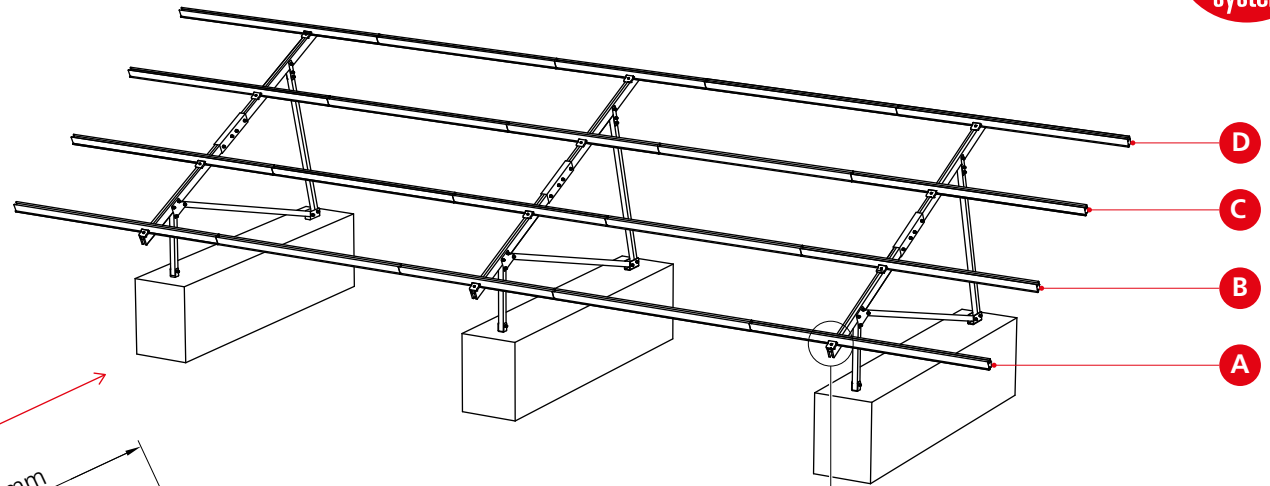

1x 2001626

9

! Torque = 14Nm!

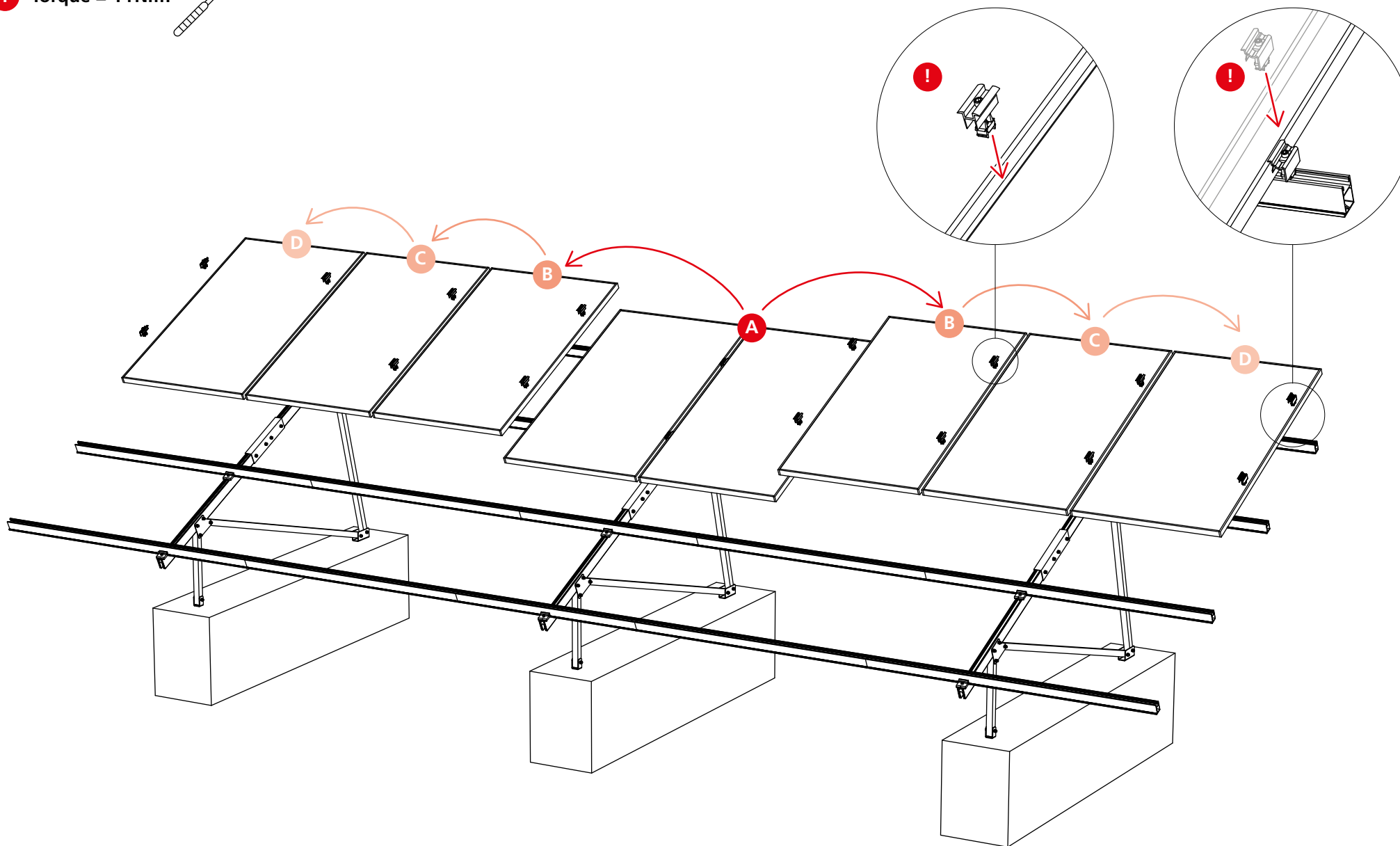

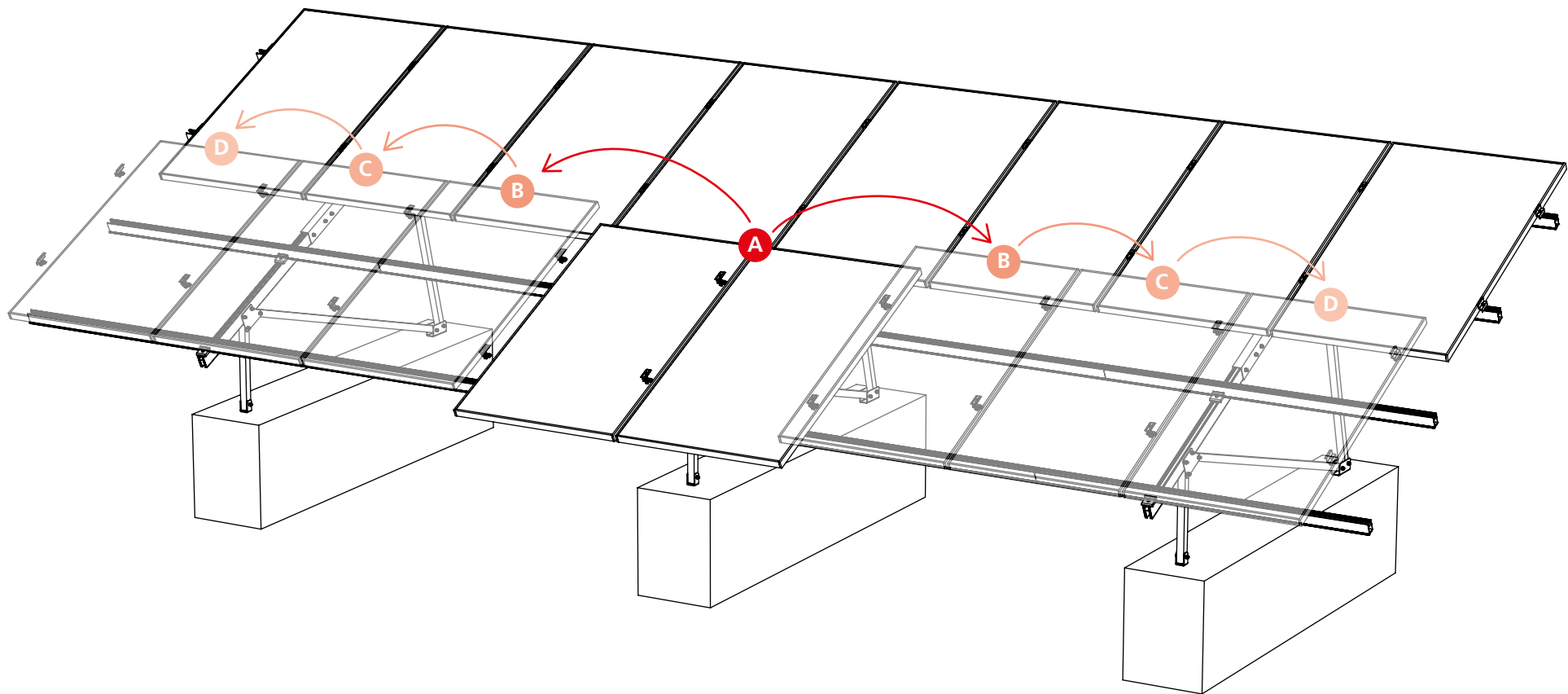

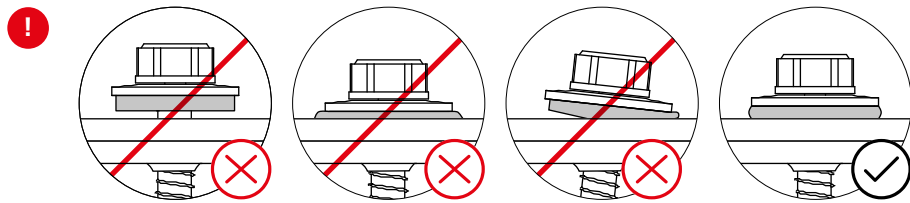
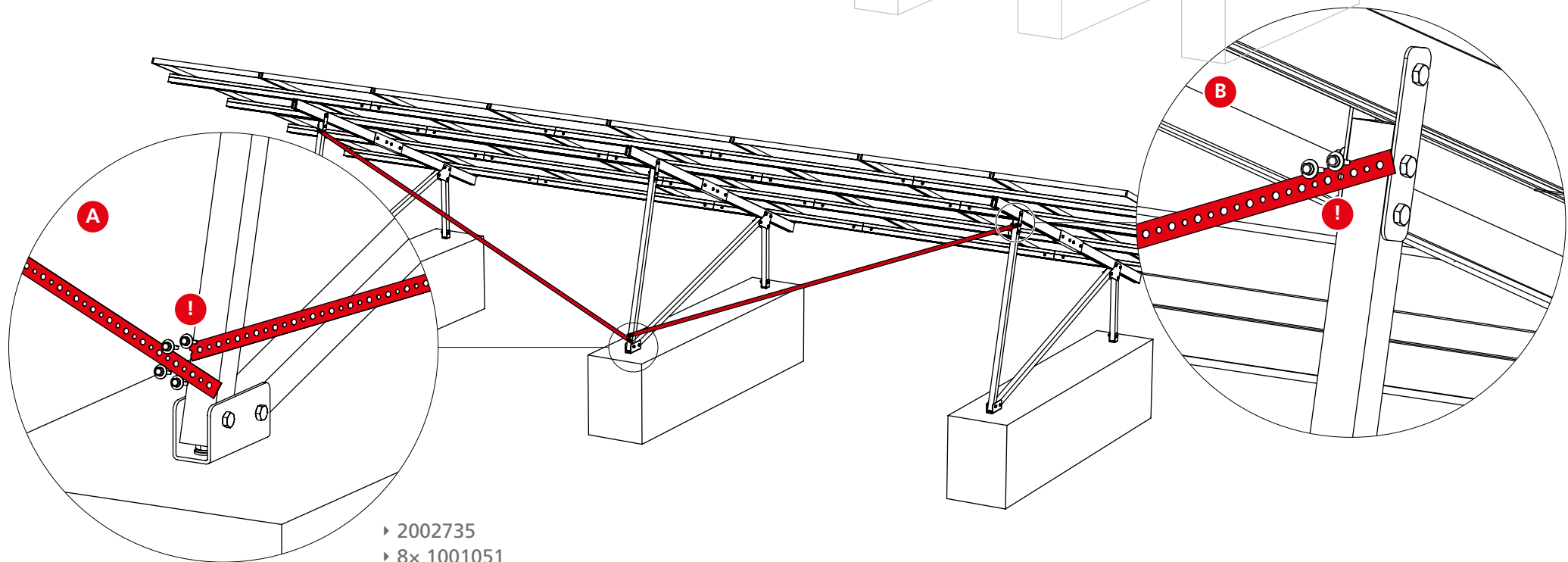
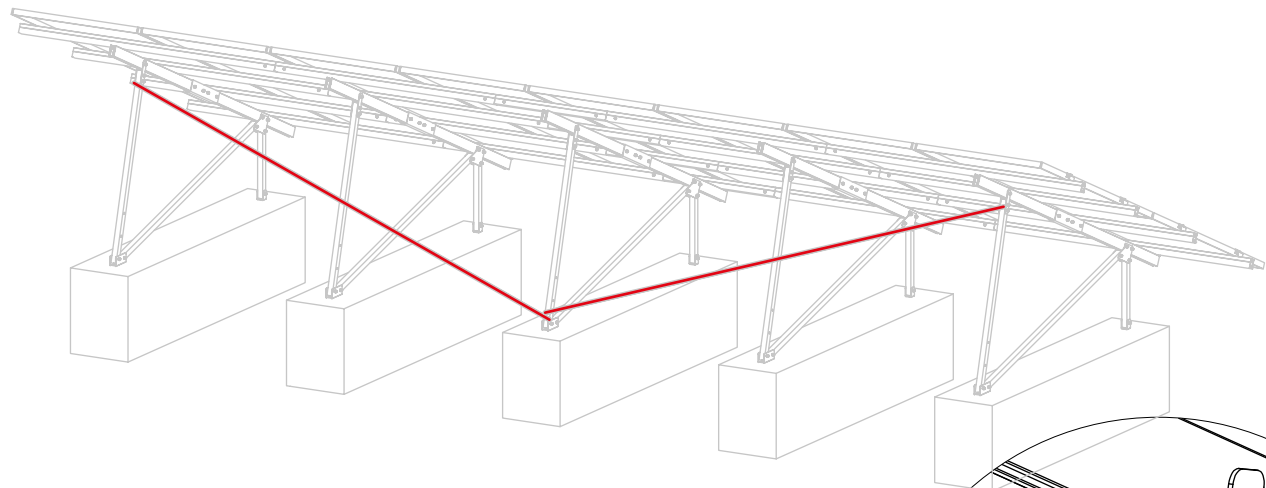

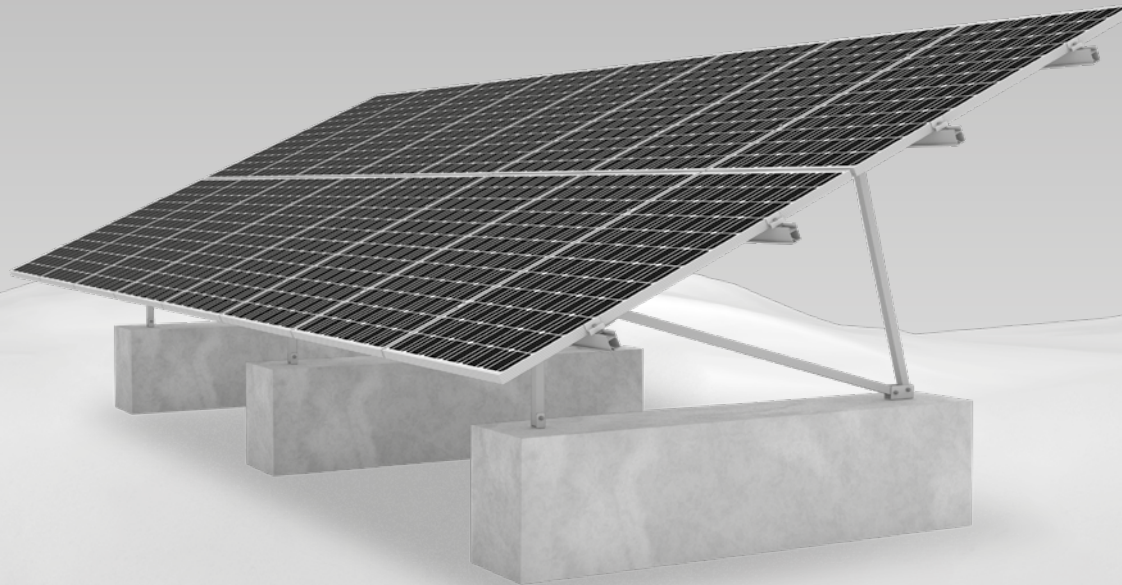

THANK YOU FOR CHOOSING A K2 MOUNTING SYSTEM.

Systems from K2 Systems are quick and easy to install. We hope these instructions have helped. Please contact us with any questions or suggestions for improvement.

Our contact data:

- ▶ www.k2-systems.com/en/contact
- ▶ **Service Hotline: +49 (0)7159 42059-0**

German law shall apply excluding the UN Convention on CISG. Place of venue is Stuttgart.

Our General Terms of Business apply. Please refer: www.k2-systems.com