

Assembly instructions

D-Dome V System



Content

| | |
|--|----|
| ▶ Tools overview | 4 |
| ▶ General safety information | 5 |
| ▶ The following guidelines apply | 6 |
| · Roof requirements | 6 |
| · Static requirements | 6 |
| · Important mounting instructions | 6 |
| ▶ Components | 8 |
| · Base components | 8 |
| · Ballast | 10 |
| · Bracing | 11 |
| ▶ Preparation | 12 |
| · Assembly schemes of module blocks | 12 |
| · Examples for module blocks in the Base assembly plan | 13 |
| · Rail mounting types and distances | 14 |
| · Rail spacing | 16 |
| · Pre-assembly | 17 |
| ▶ Assembly | 18 |
| · Installation of module field and thermal separations | 18 |
| · Ballast options | 22 |
| · Edge bracing | 24 |
| · Cable management | 25 |
| · Equipotential bonding with TerraGrif | 25 |
| ▶ Notes | 26 |

Quality tested – several certifications

K2 Systems stands for secure connections, highest quality and precision. Our customers and business partners have known that for a long time. Independent institutes have tested, confirmed and certified our capabilities and components.

Please find our quality and product certificates under:
www.k2-systems.com/en/technical-information



Tools overview

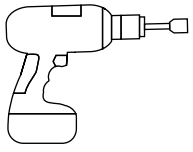

6mm

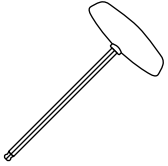

6mm



6-30Nm
(4.5-22.2lb-ft)



6mm

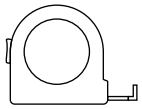

≥3.0m



≥6.0m

General safety information



Please note that our general mounting instructions must be followed at all times and can be viewed online at www.k2-systems.com/en/technical-information

- ▶ The equipment may only be installed and operated by qualified and adequately trained installers.
- ▶ Prior to installation, ensure that the product complies with on-site static loading requirements. For roof-mounted systems, the roof load-bearing capacity must always be checked.
- ▶ National and local building regulations and environmental requirements must be adhered to.
- ▶ Compliance with health and safety regulations, accident prevention guidelines and applicable standards is required.
 - Protective equipment such as safety helmet, boots and gloves must be worn.
 - Roofing works must be in accordance with roofing regulations utilising fall protection safeguards when eaves height exceeds 3 m.
 - At least two people must be present for the duration of the installation work in order to provide rapid assistance in the event of an emergency.
- ▶ K2 mounting systems are continuously developed and improved and the installation process may thereby change at any time. Prior to installation consult our website at www.k2-systems.com/en/technical-information for up-to-date instructions. We can send you the latest version on request.
- ▶ The assembly instructions of the module manufacturer must be adhered to.
- ▶ Equipotential bonding/grounding/earthing between individual parts is to be performed according to country specific standards, as well as national laws and regulations.
- ▶ At least one copy of the assembly instructions should be available on site throughout the duration of the installation.
- ▶ Failure to adhere to our general safety and assembly instructions and not using all system components, K2 is not liable for any resulting defects or damages. We do not accept liability for any damage resulting in the use of competitor's parts. Warranty is excluded in such cases.
- ▶ German law shall apply excluding the UN Convention on CISG. Place of venue is Stuttgart. Our General Terms of Business apply.
- ▶ If all safety instructions are adhered to and the system is correctly installed, there is a product warranty entitlement of 12 years! We strongly recommend reviewing our terms of guarantee, which can be viewed at www.k2-systems.com/en/technical-information We will also send this information on request.
- ▶ Dismantling of the system is performed in reverse order to the assembly.
- ▶ K2 stainless steel components are available in different corrosion resistance classes. Each structure or component must be carefully checked for possible corrosion exposure.

The following guidelines apply

The D-Dome V system can be installed as standard under the following conditions. Even if the system is capable of meeting higher demands through the integration of safety standards, please get in touch with your contact at K2 Systems if the specified values are exceeded.



Roof requirements

- ▶ This system can be used on all established flat roof constructions with a pressure resistant substrate and a roof pitch of up to 3°.
- ▶ The roof surface must be clean and dry. Roof irregularities must be corrected or removed where appropriate.
- ▶ The coefficient of friction of the roof must be determined on-site.
See video k2-systems.com/en/friction-coefficient



Static requirements

- ▶ It is essential to check the roof structure has sufficient residual load capacity and the pressure capacity of the heat insulation on site.
- ▶ For framed modules with a frame height of 30-50 mm
- ▶ Permissible module dimensions: length 1386-2100 mm, width 985-1053 mm



Important mounting instructions

Mounting system

- ▶ The inclination of the D-Dome V system is 10°.
- ▶ The mounting system is assembled step-by-step together with the modules, i.e. the modules must also be on site during the assembly.
- ▶ A minimum distance to the roof edge of 600 mm must be observed.
- ▶ The compatibility of the roof covering and the Mat V support pad must be checked.
- ▶ At least two elevations must be assembled discontinuous to use this mounting system.
- ▶ Ensure a thermal separation (distance between module blocks) after a maximum of 15.5 m in the module row direction and in the direction of the base rail.
- ▶ In the event of exceptional circumstances (such as storms, heavy rain, earthquakes, etc.), the system should be checked by a specialist. Should an inspection find damage or plastic deformation (such as in the module clamp area) the components must be replaced.

Modules and clamping

- ▶ Tightening torque of 14Nm for all module clamps.
- ▶ Adhere to module manufacturer recommendations for clamping area and module installation (see module manufacturer instructions). Check whether manufacturer approval is available for corner clamping. See k2-systems.com/en/approved-modules

General information

- ▶ External influences that act on this system are only reflected in the design of the ballast to a limited degree. For instance, unevenness, thermal elongation, moss, water accumulation and ageing of the sheeting cannot be considered, although these factors might also precipitate system displacement under certain circumstances. We recommend you check whether the system requires additional mechanical attachment, as the impact of these influences may be greater on slanted roofs.
- ▶ It is important to ensure that the rain water flow is not hindered.
- ▶ Because of the different orientation of the solar modules, the string and inverter connection must be appropriately observed. It is recommended that the inverters and strings are connected separately.
- ▶ On-site general standards and regulations for lightning protection must be observed and consultation with a specialist to create a lightning protection concept is recommended (use lightning protection clamp if necessary).

Components

Base components

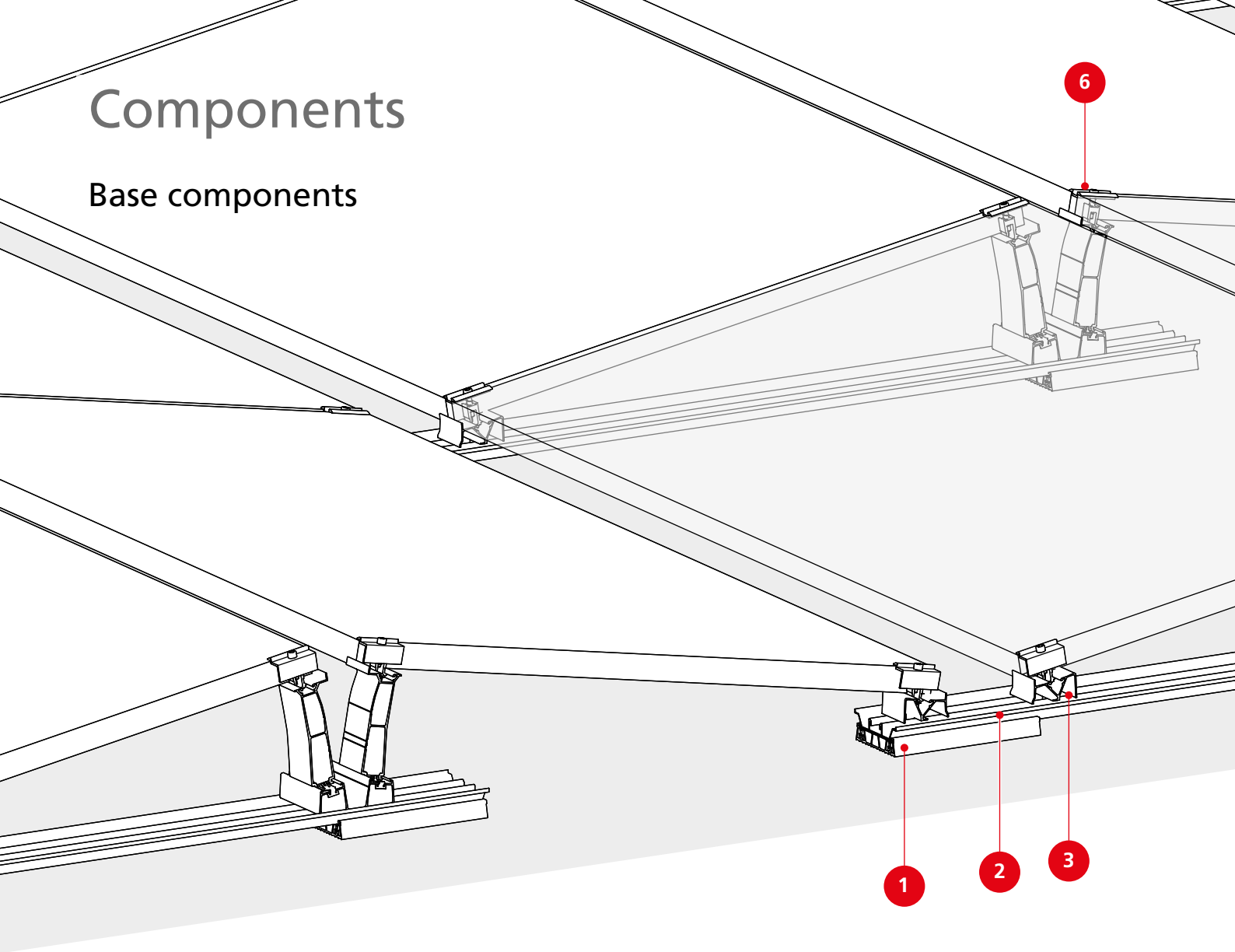

1 2002849
Dome V Mat V

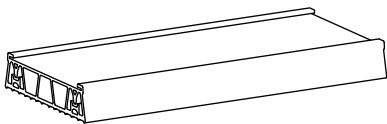

2 2002911/2002854
Dome V Rail · 2650/1500mm

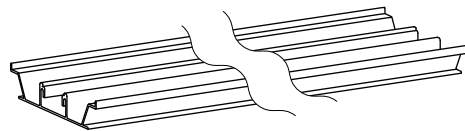

3 2002828
Dome V SD

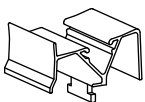

4 2003178
D-Dome V Set

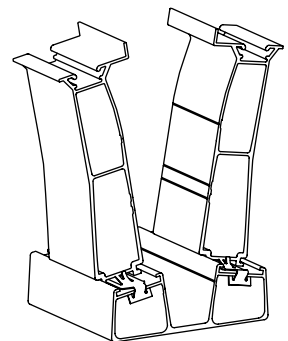

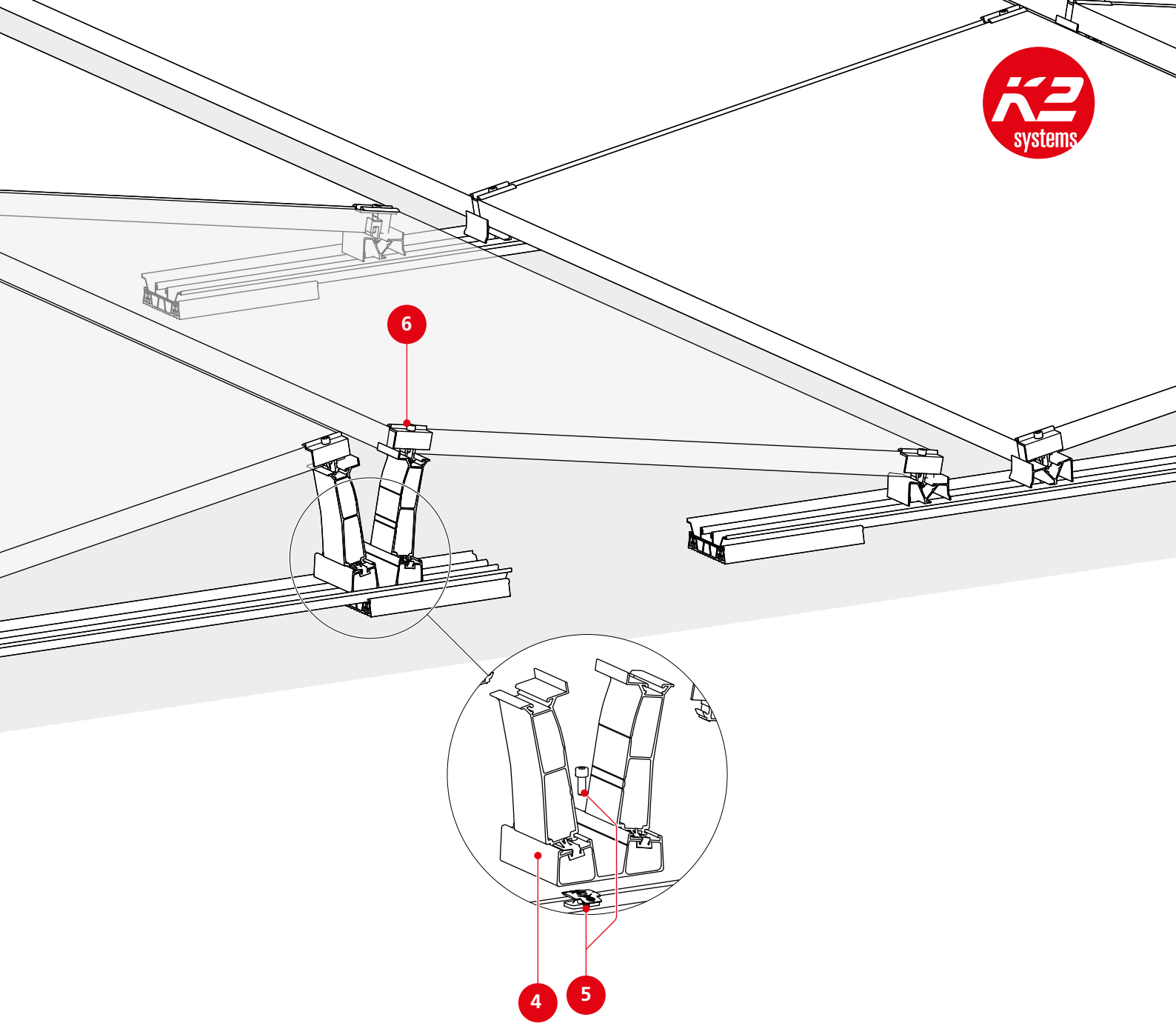

5 1001643 + 2001729
MK2 Slot nut with clip +
Allen bolt M8x20

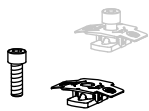

6 2002559/2002558
MiniClamp EC/MC

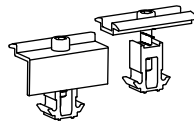

Optional

2002870
Cable-Manager

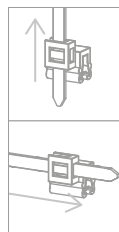
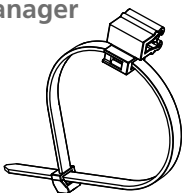

2002649
TerraGrif K2MI

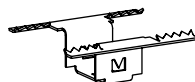

Components

Ballast

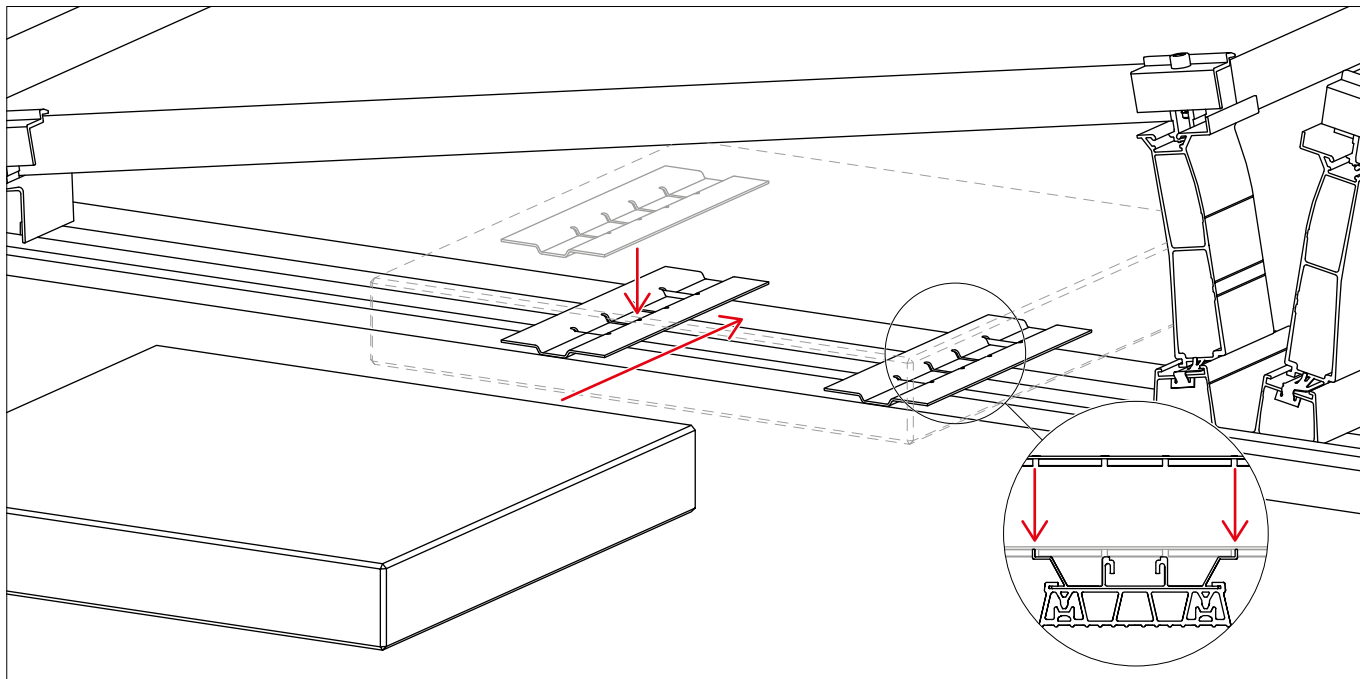

2002830
SpeedPorter Dome V

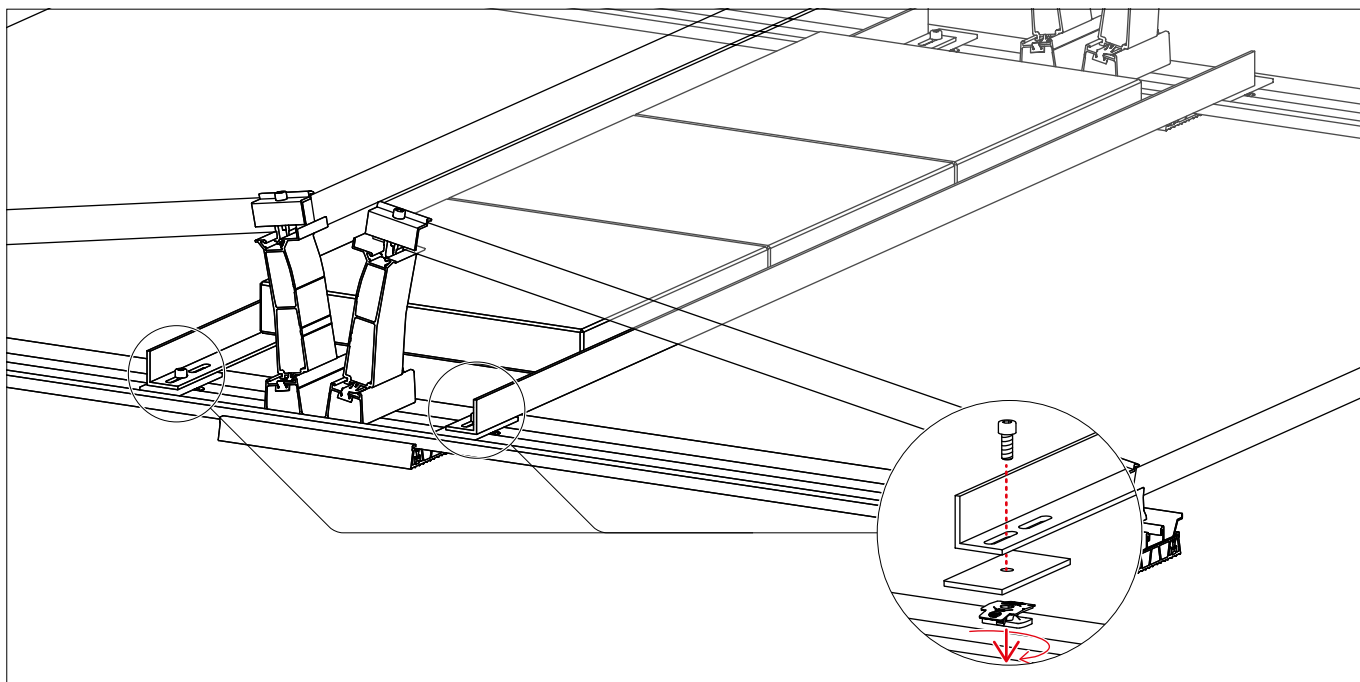
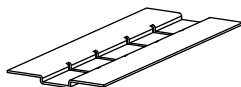

2000081/2001140
Porter

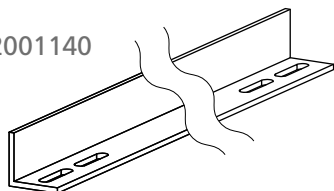

1001643 + 2001729
MK2 Slot nut with clip +
Allen bolt M8x20

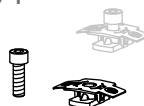

1000789
Underlay plate Porter



Bracing

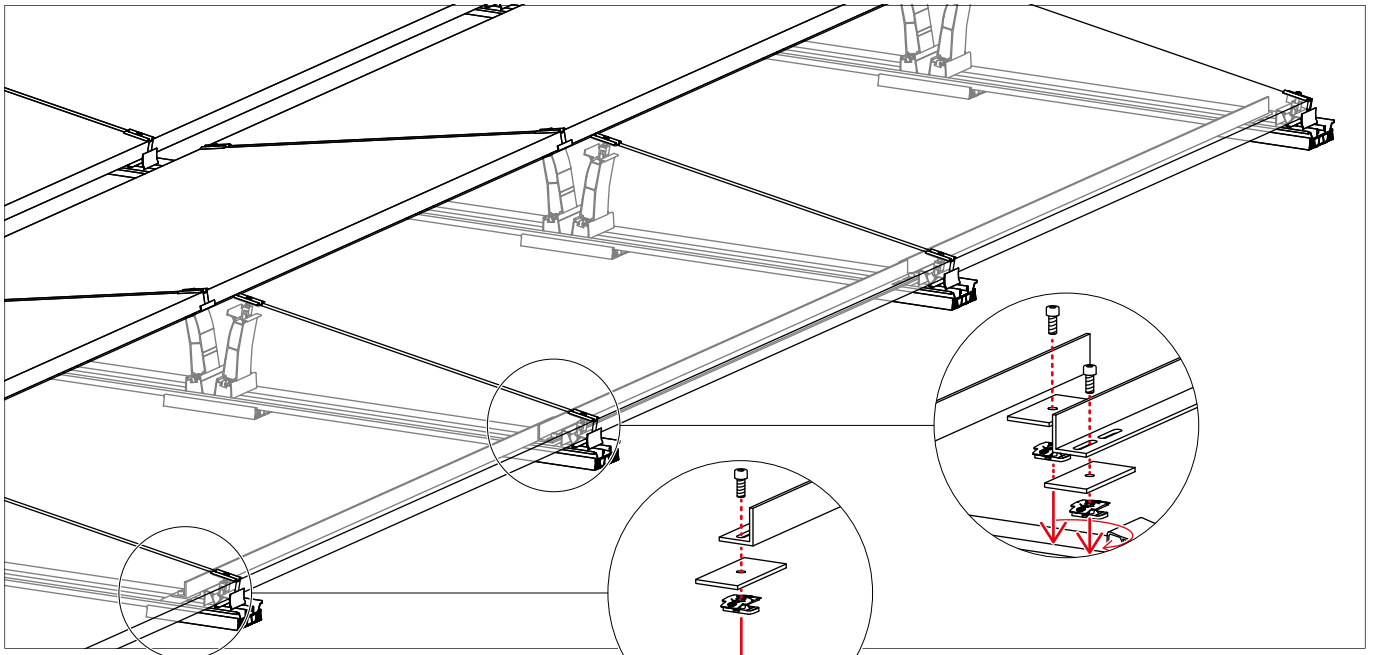

2000081/2001140
Porter

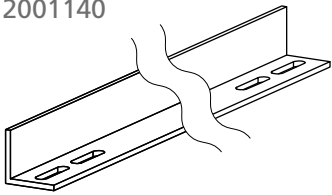

1001643 + 2001729
MK2 Slot nut with clip +
Allen bolt M8x20

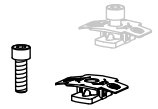

1000789
Underlay plate Porter



Preparation

Assembly schemes of module blocks

! Quantities: Note assembly plan Base!

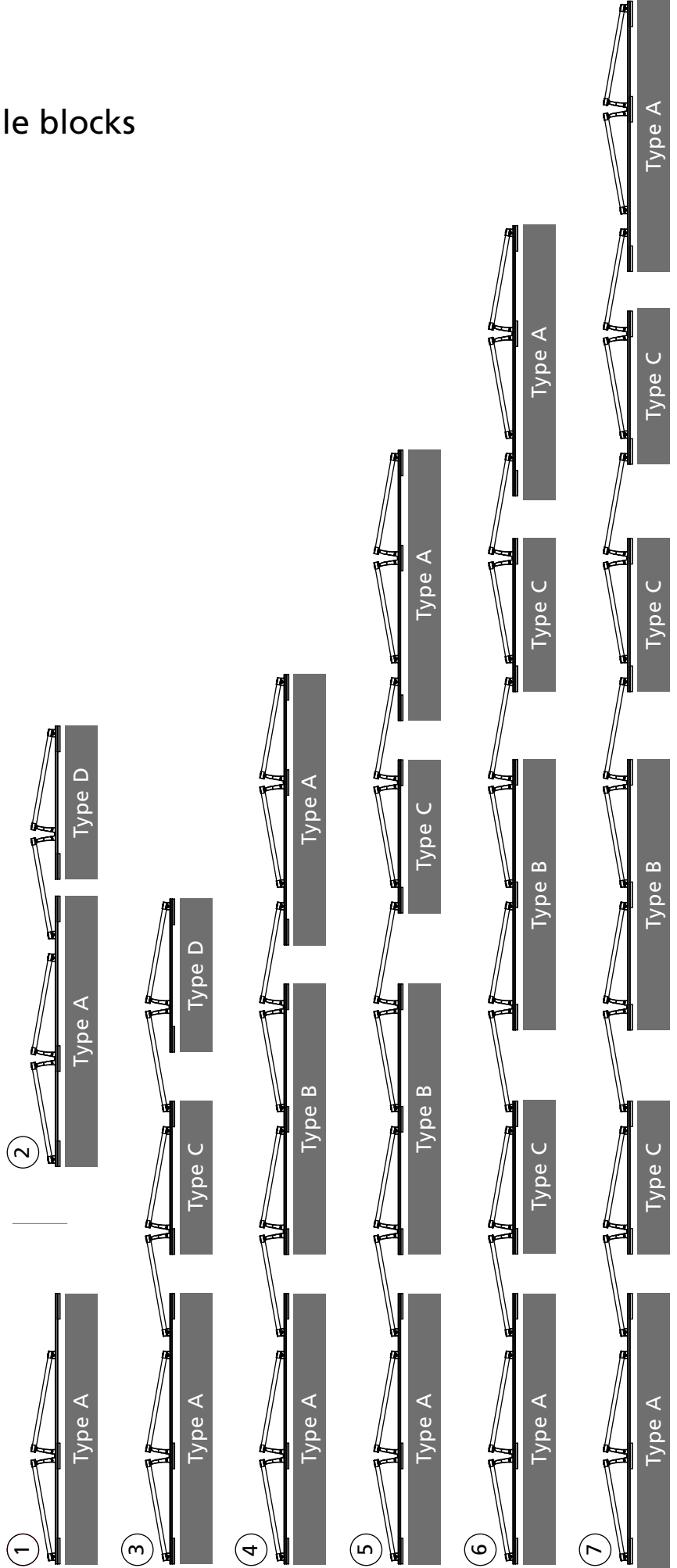
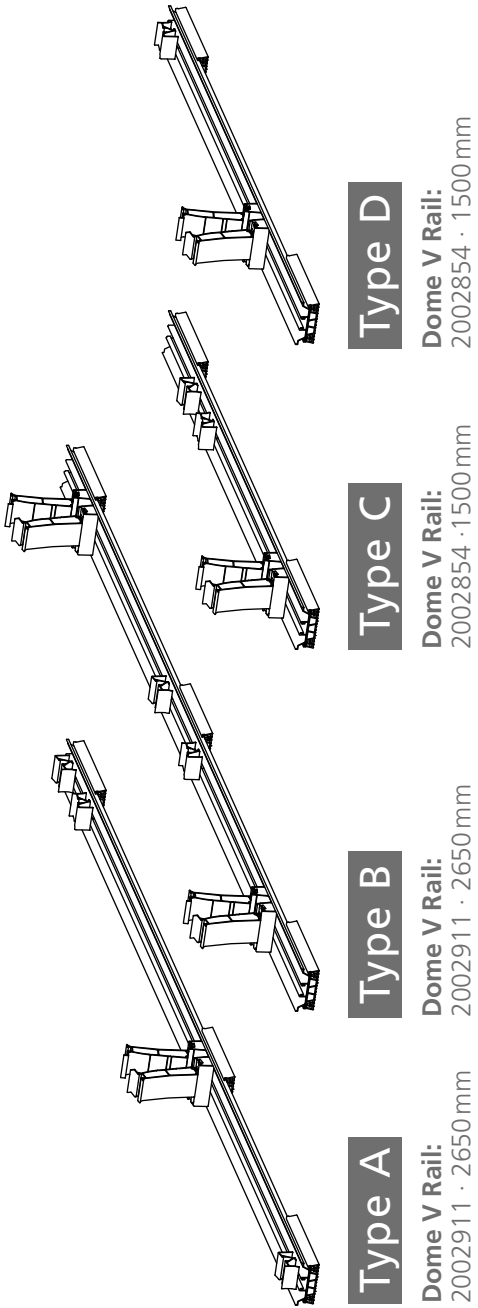

Examples for module blocks in the Base assembly plan

Example pre-assembly dimensions

Module Array 1

Row distance 2172 mm
 Maintenance corridor (e) 140 mm
 Assembling jig (d) 2042 mm is suggested

| Type | Quantity | Pre-assembly measurement [mm] | |
|------|----------|-------------------------------|------------|
| A | 175 | a | 987 |
| B | 70 | b / d | 174 / 2042 |
| C | 210 | c | 167 |
| D | 22 | a / a1 | 987 / 383 |

! The dimensions for the variables a, a₁, b, c and d are to be used during pre-assembly – see page 14 or 15.

Example 1

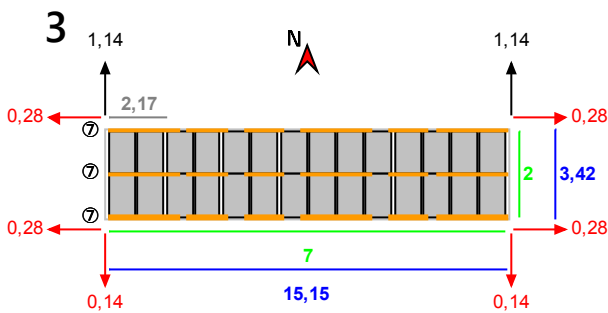

! Base displays the assembly plans in this view.

- ⊘ Assembly schemes for the elevation row – see left!
- ← Distance to neighbouring module array [m]
- ← Distance to roof edge [m]
- Number of modules
- Length/width of module array [m]
- 2,17 Row distance [m]
- Rail

Example 2

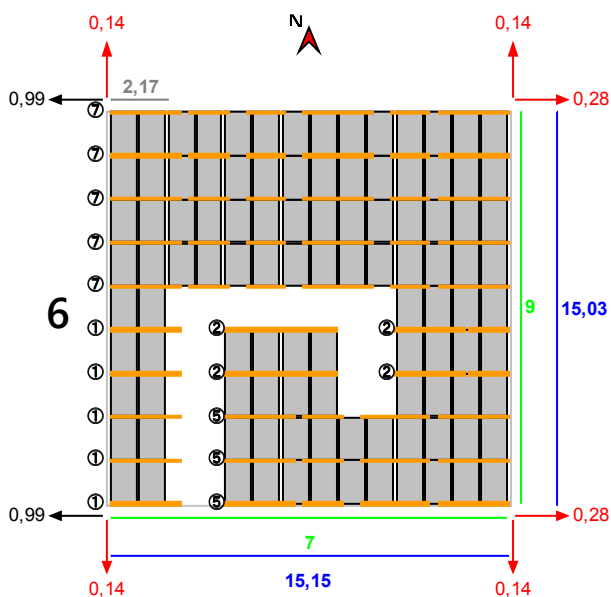

Preparation

Rail mounting types and distances

Type A

Dome V Rail:
2002911 · 2650mm

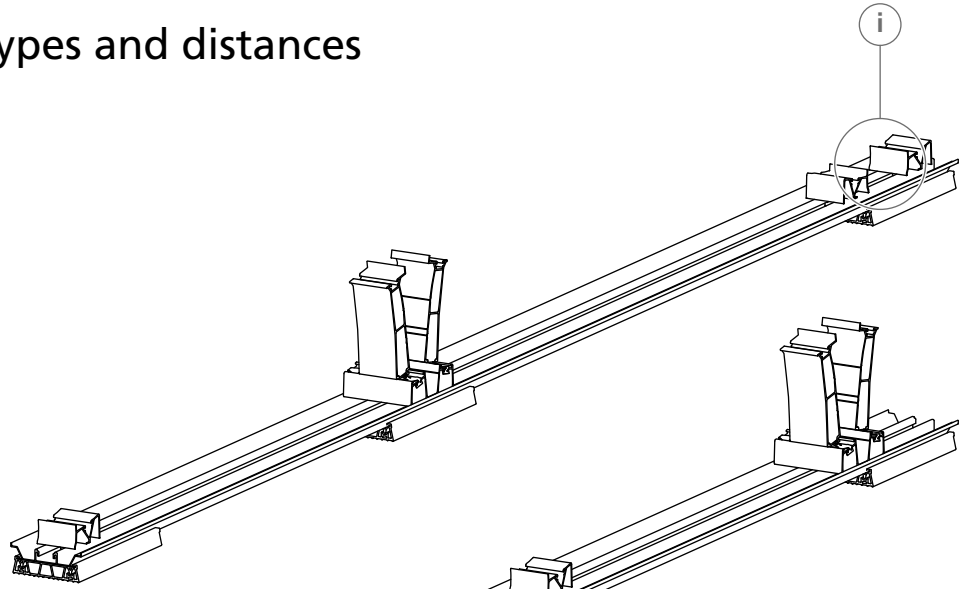

Type B

Dome V Rail:
2002911 · 2650mm

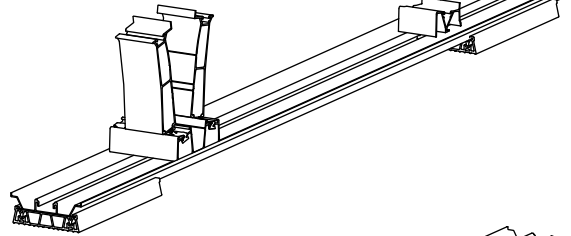

Type C

Dome V Rail:
2002854 · 1500mm

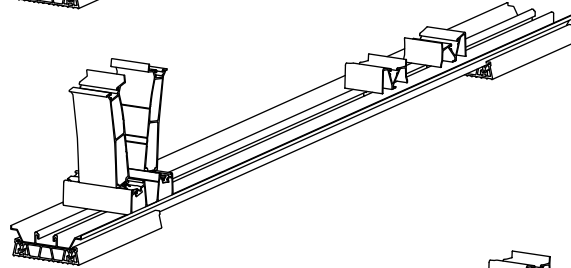

Type D

Dome V Rail:
2002854 · 1500mm

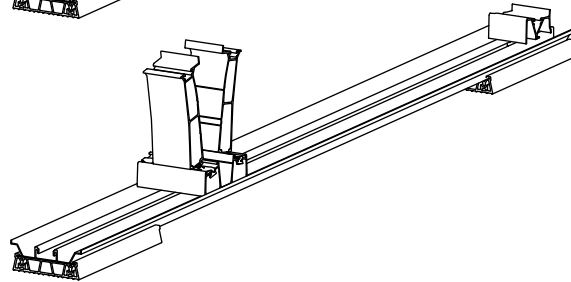

i For free-standing double modules or double modules within a module block, the second Dome V SD is not required.

! Base displays the pre-assembly dimensions for the rail types in tabular form in the chapter "Pre-assembly". See examples on page 13!

Type A

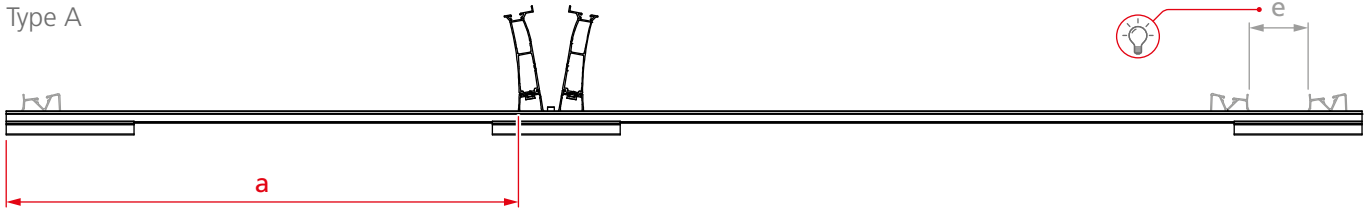

Type B

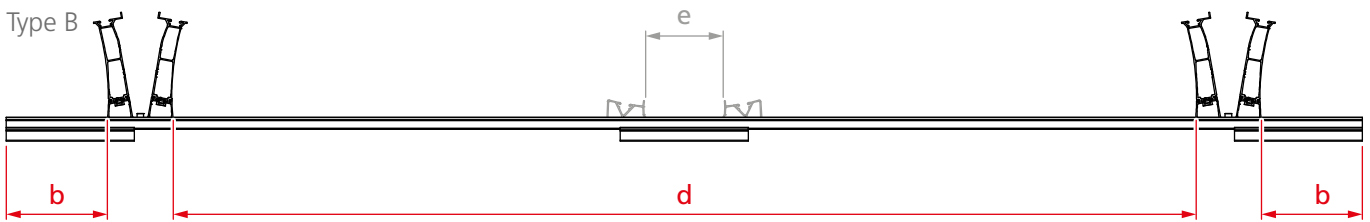

Type C

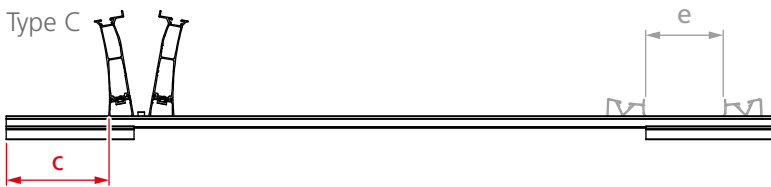

Type D

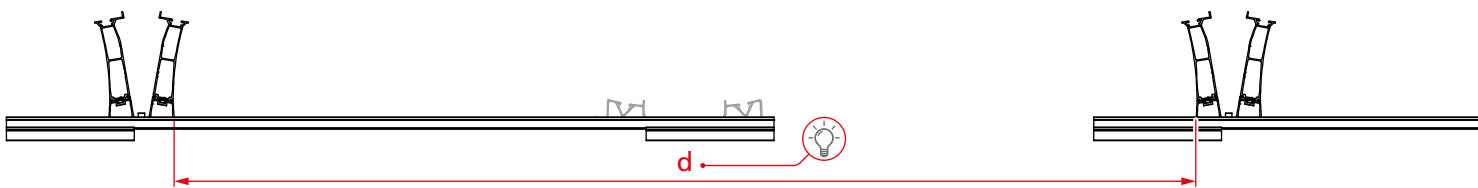
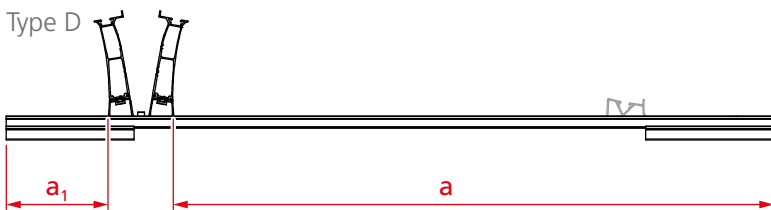

Calculations of pre-assembly dimensions of types A, B, C, D:

$a = (0,99 \times \text{module width}) + 8$ [mm]

$a_1 = 1372 - a$ [mm]

$b = \frac{(2522 - \text{row distance})}{2}$ [mm]

$c = 1288 - \text{maintenance walkway} - (\text{module width} \times 0,99)$ [mm]

$d = \text{row distance} - 128$ [mm]

$e = \text{maintenance walkway}$ [mm]

Pre-assembly dimensions d and e

For "d" and "e" we suggest an assembling jig!

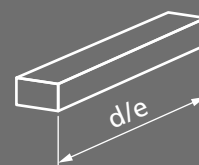

Preparation

Rail spacing

Calculation of rail spacing:

$$r = \text{module width} - 105 \text{ [mm]}$$

Pre-assembly dimension r



For „ r “ we suggest an assembling jig!

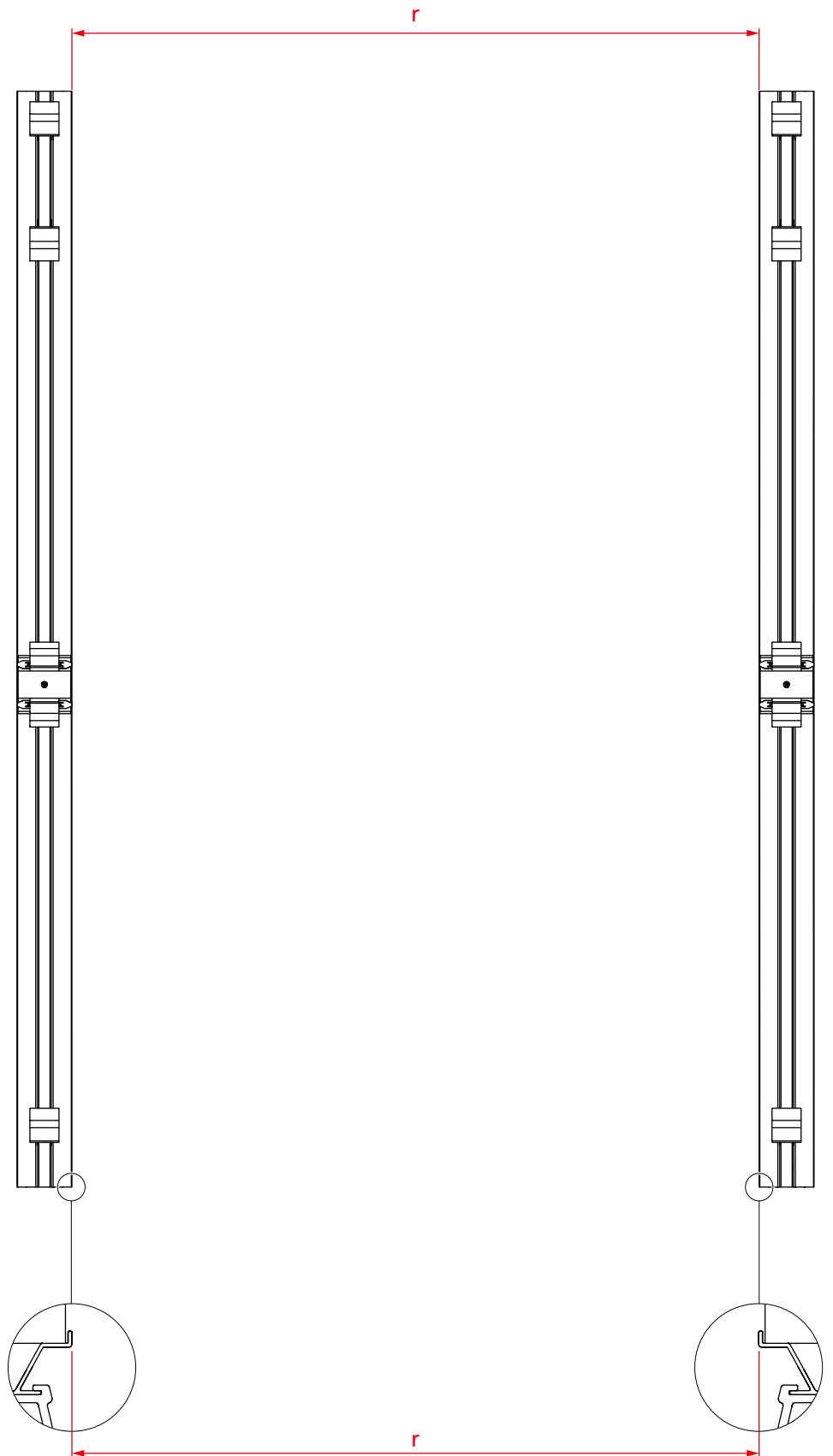
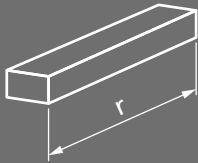

Pre-assembly

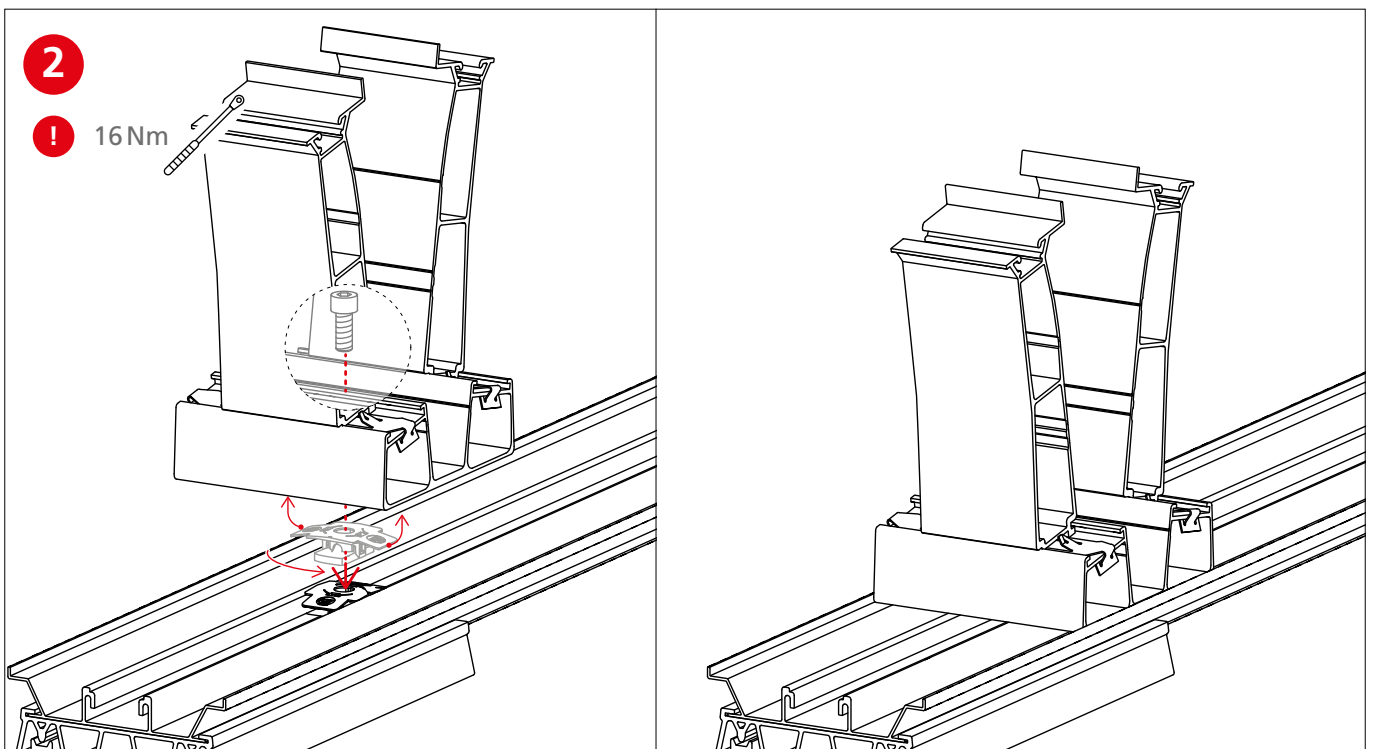
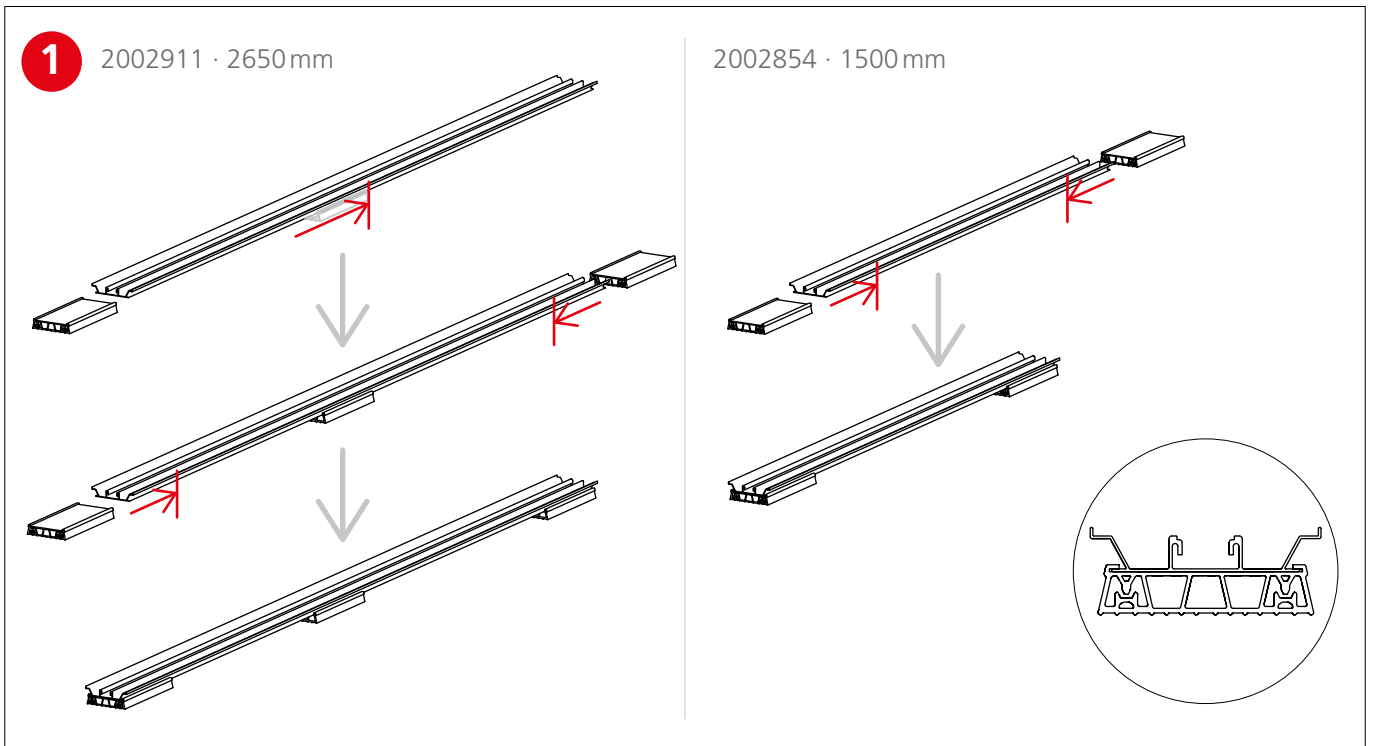

Assembly

Installation of module field and thermal separations

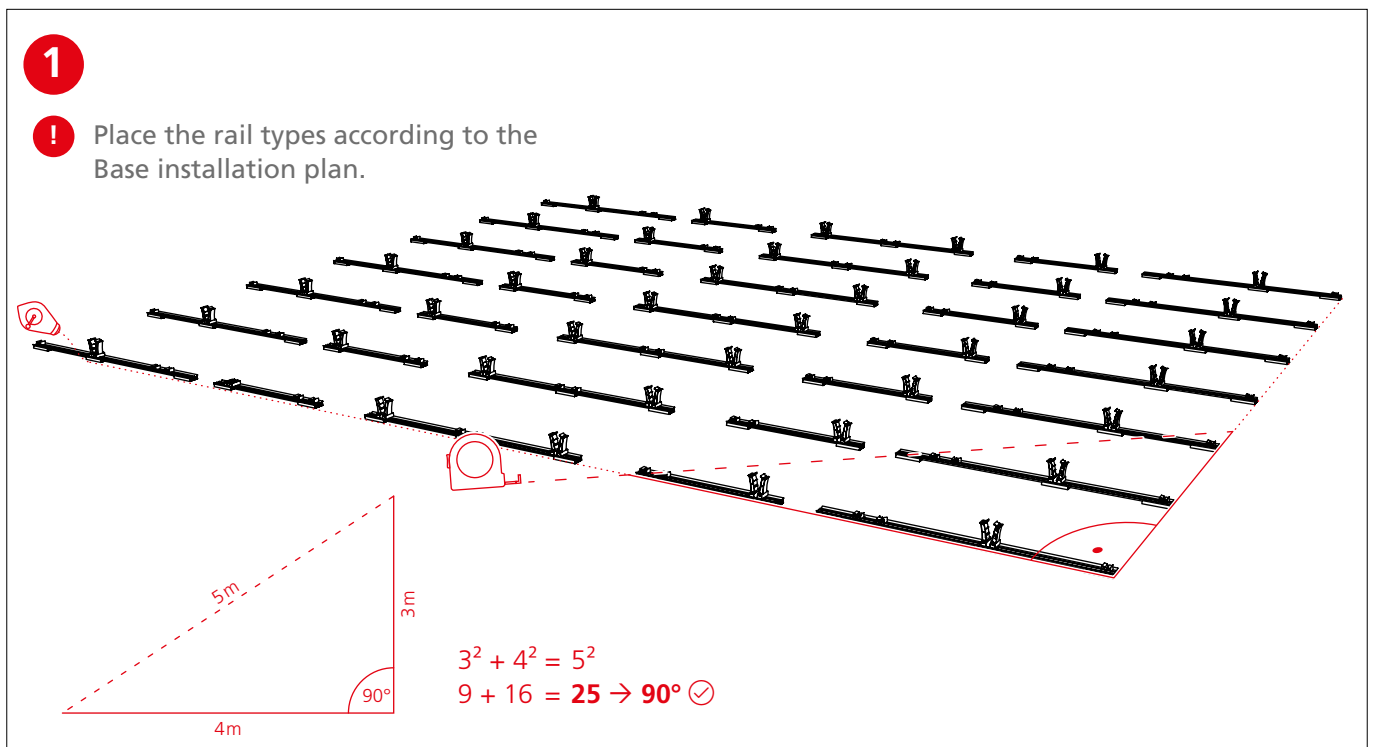
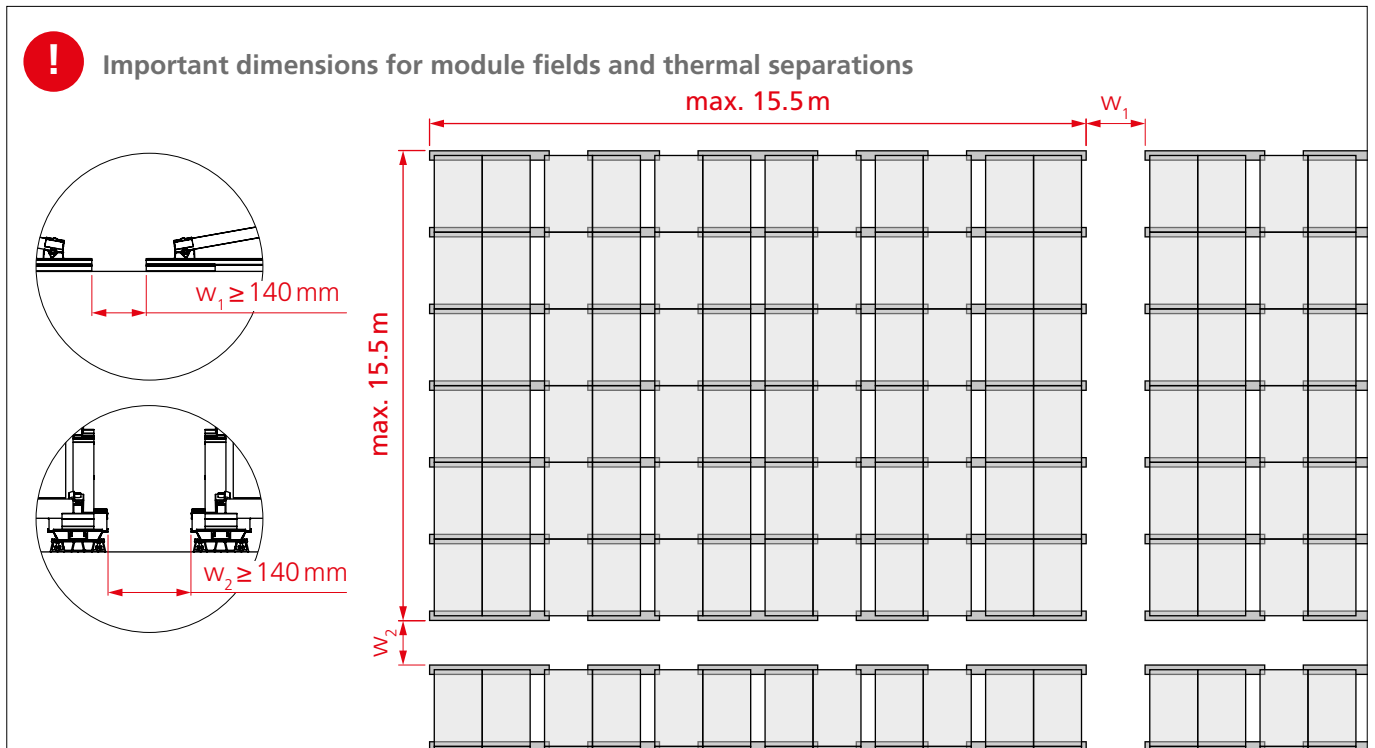

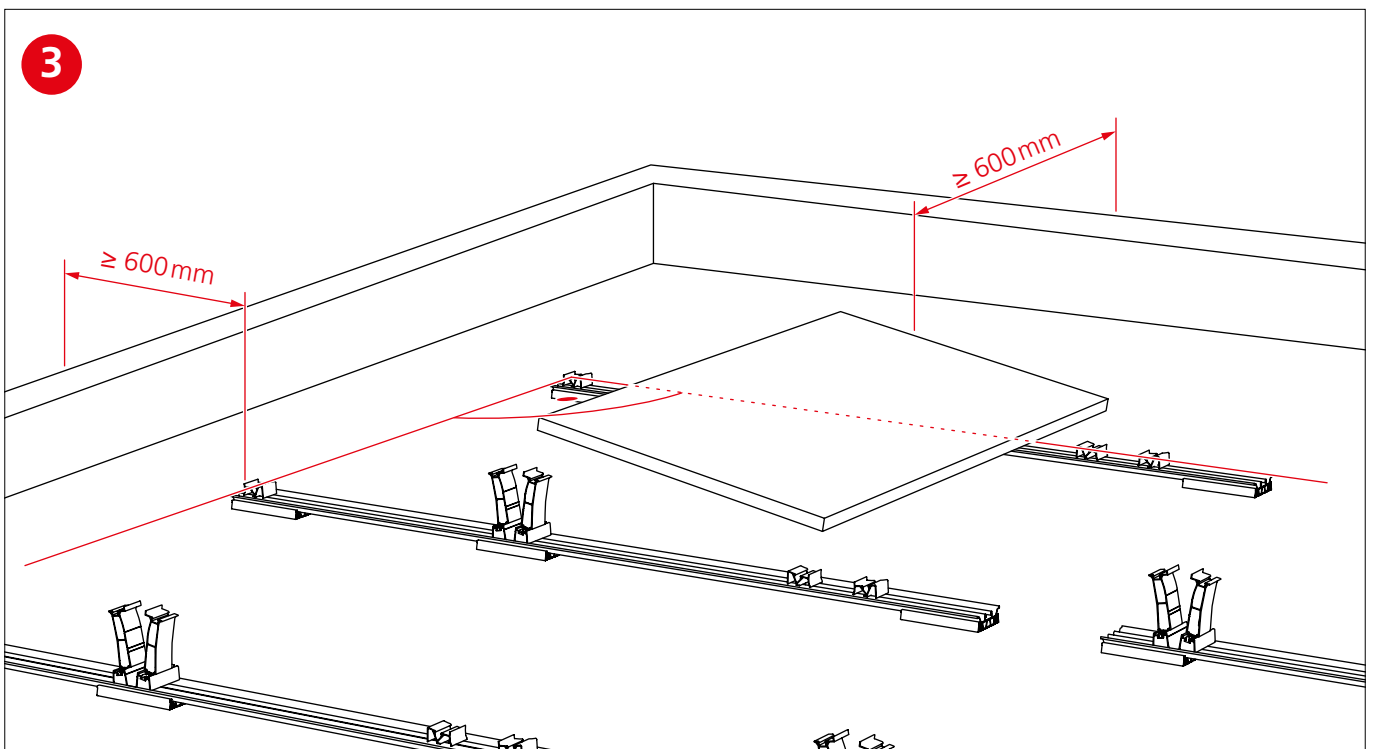
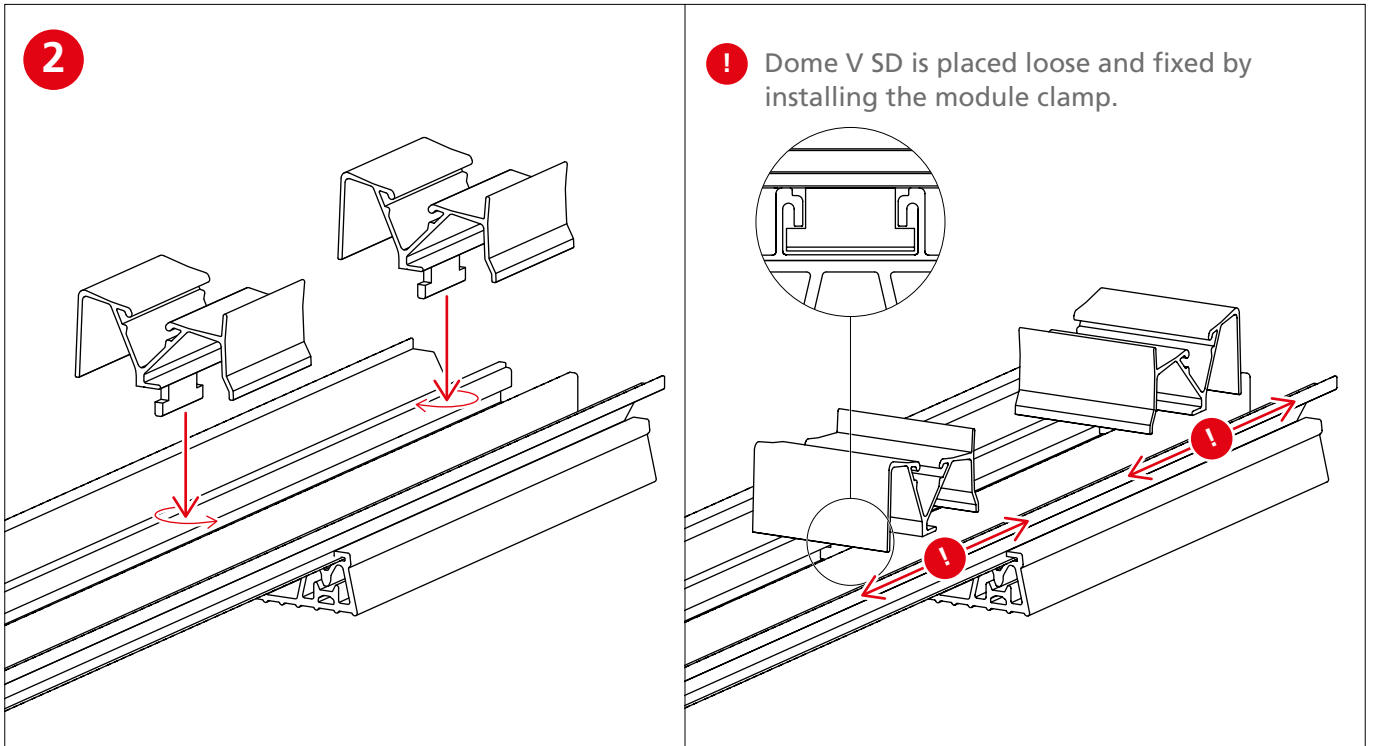

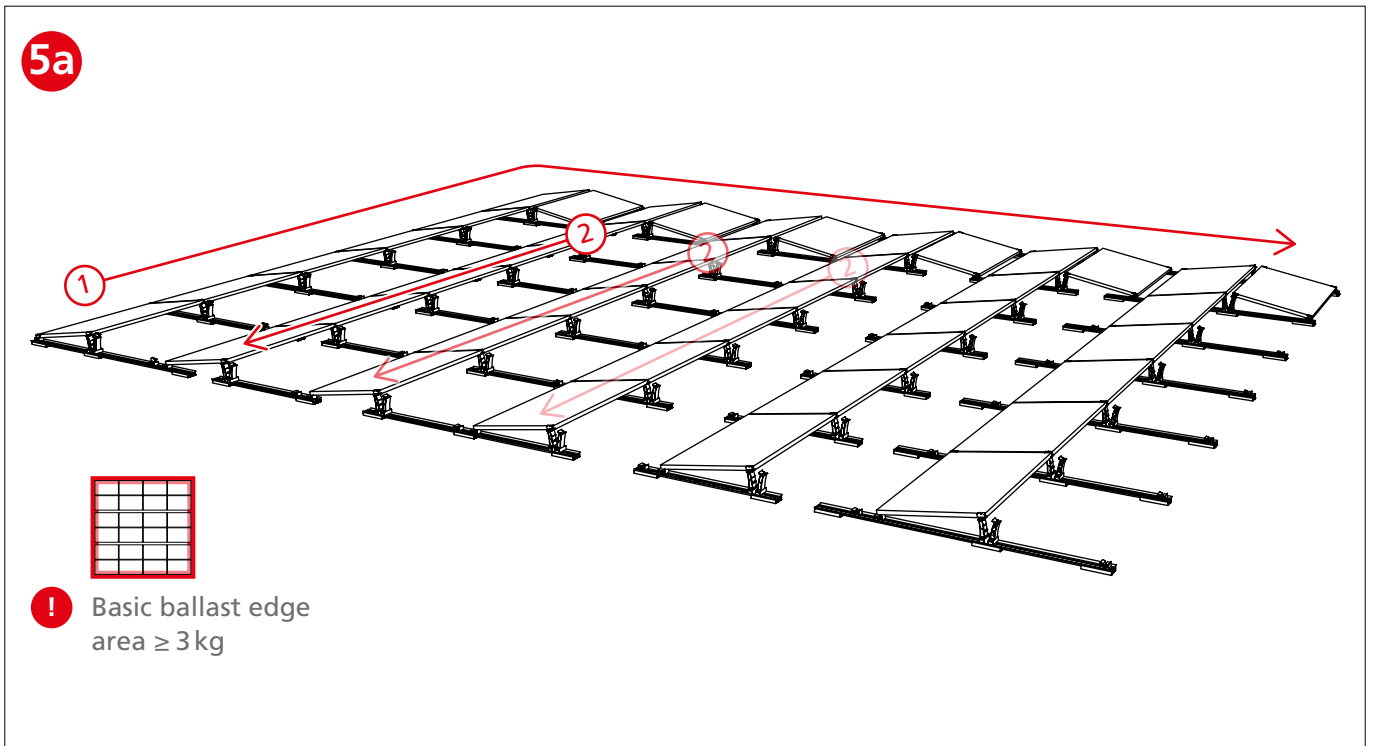
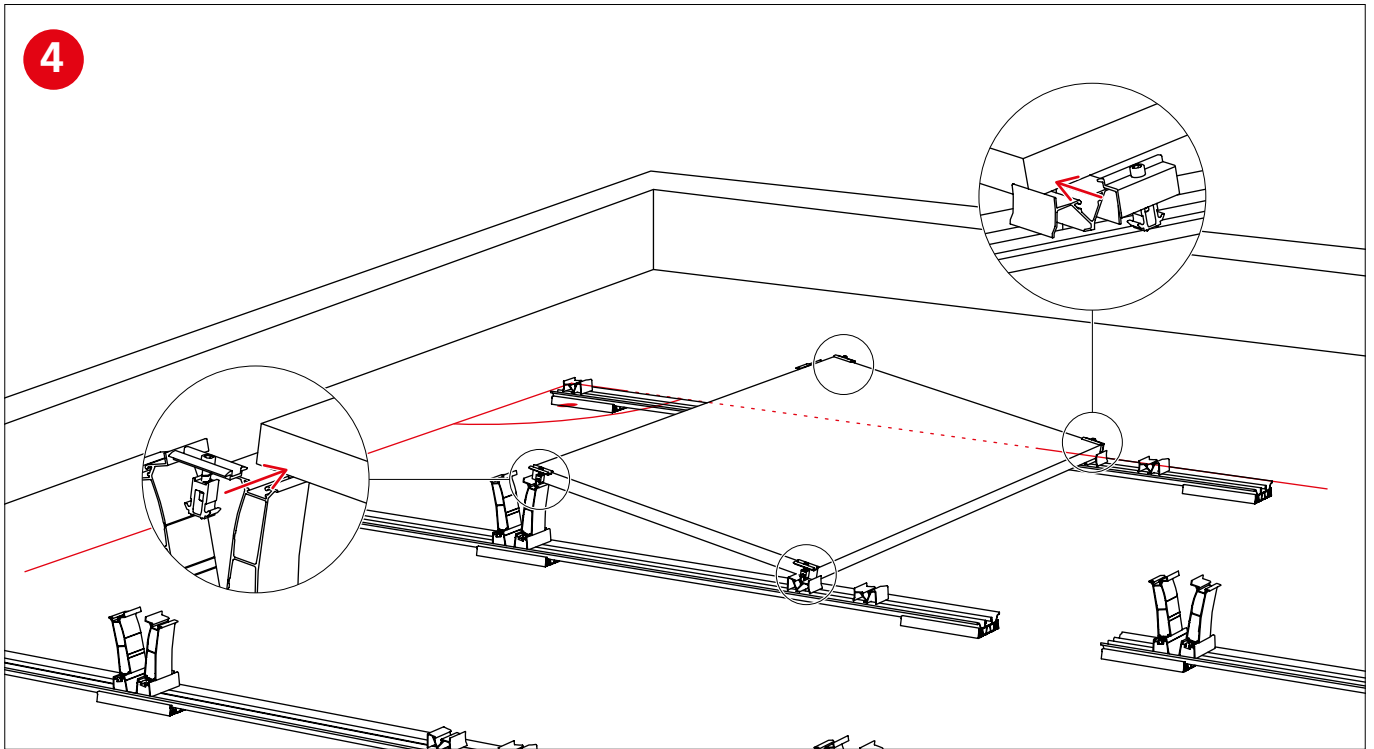

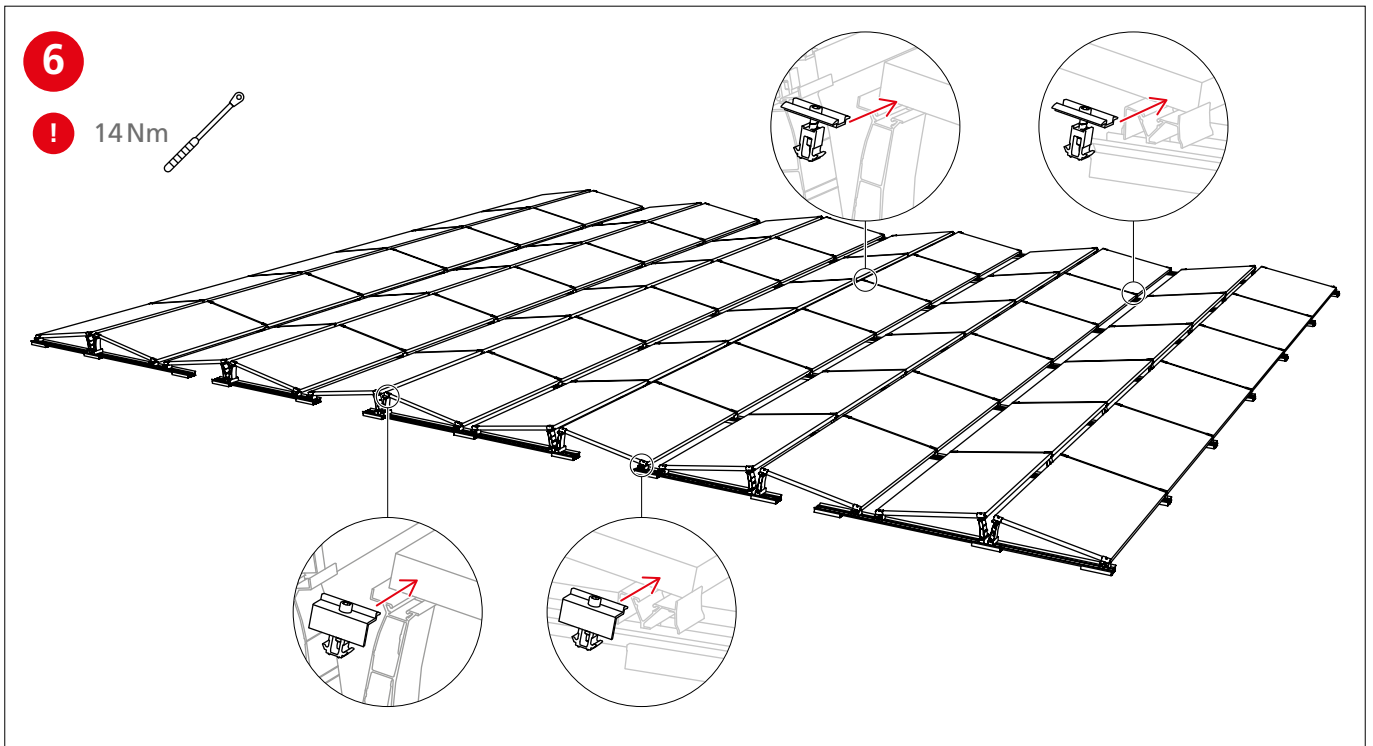
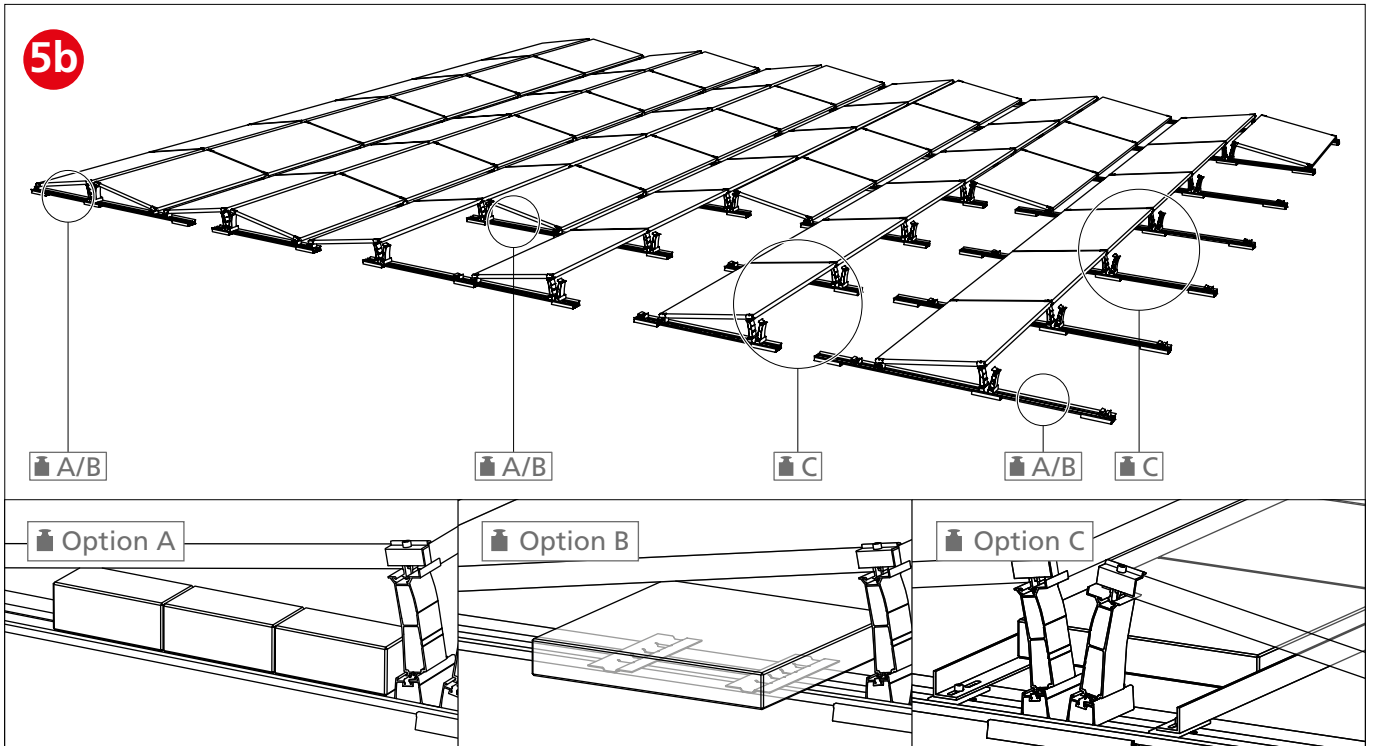

Ballast options

Ballast data: See Base ballast plan!

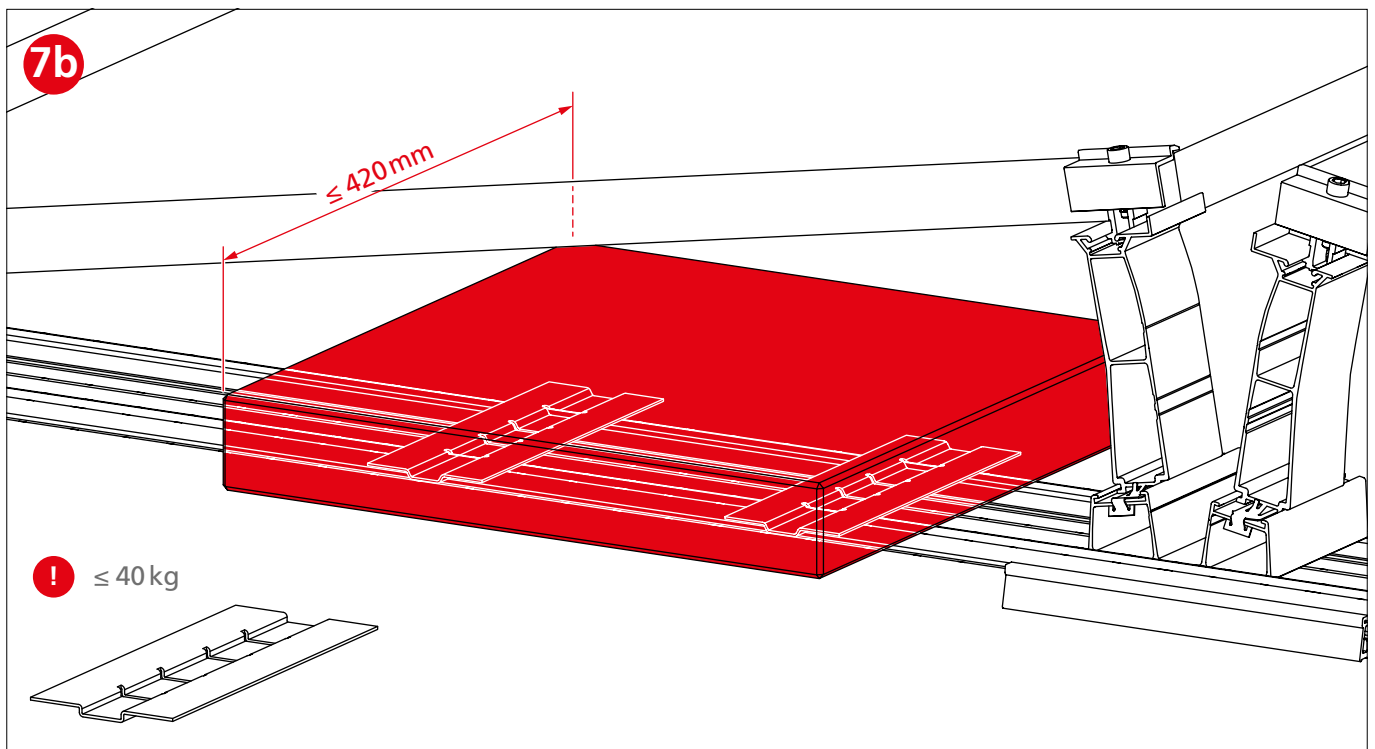
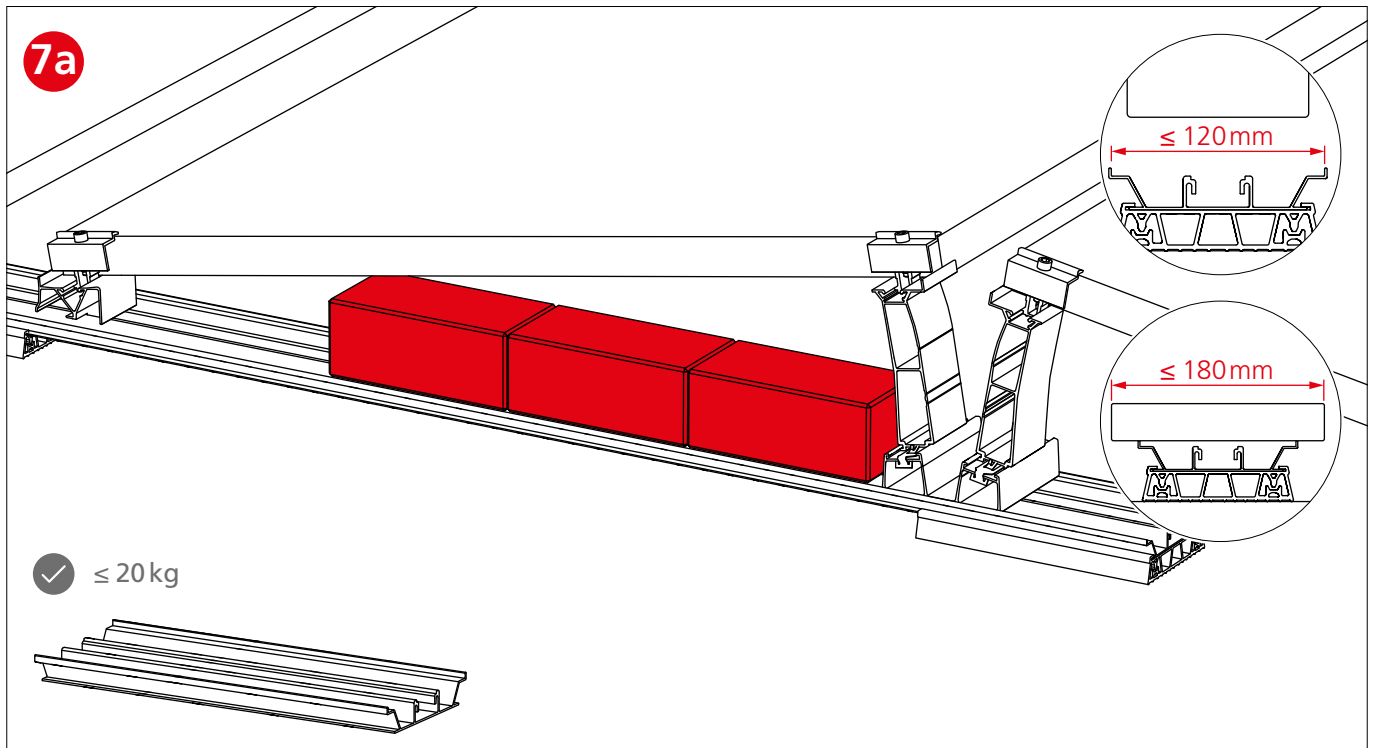

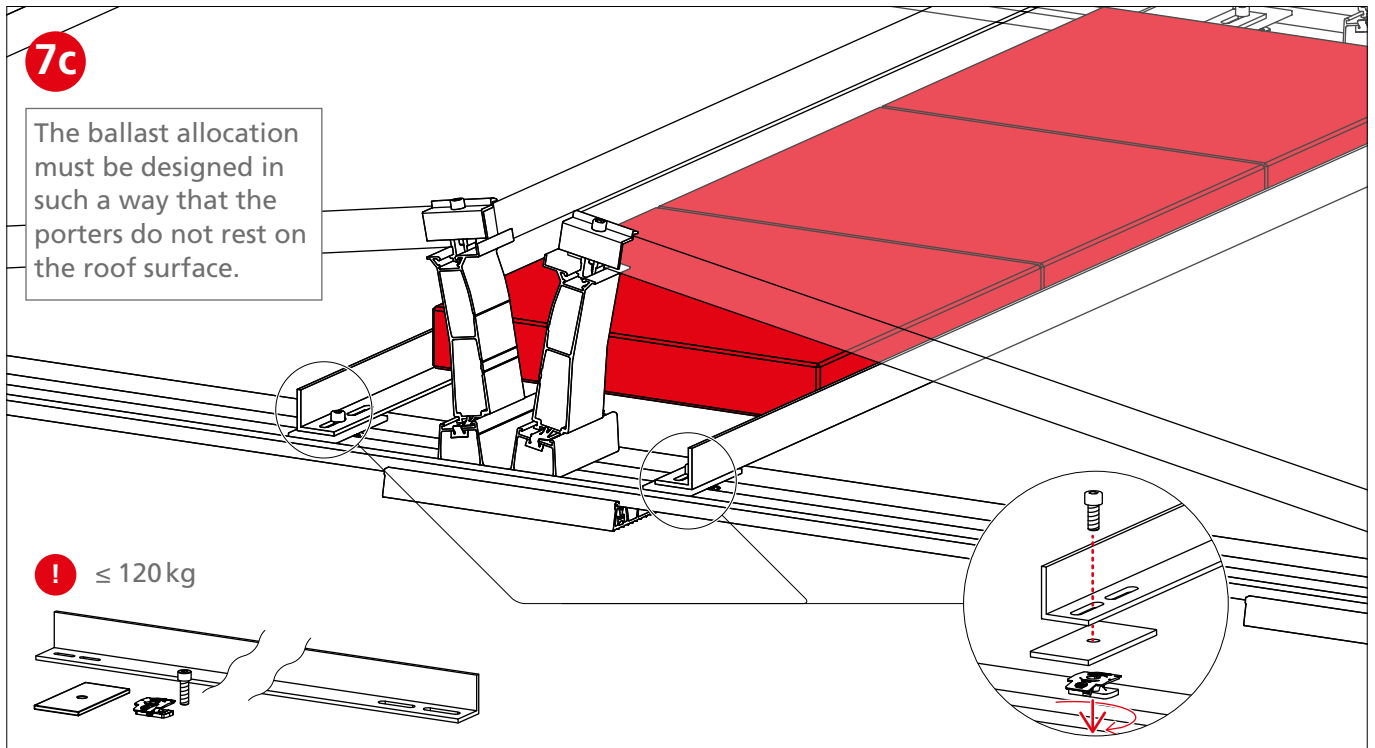

Edge bracing

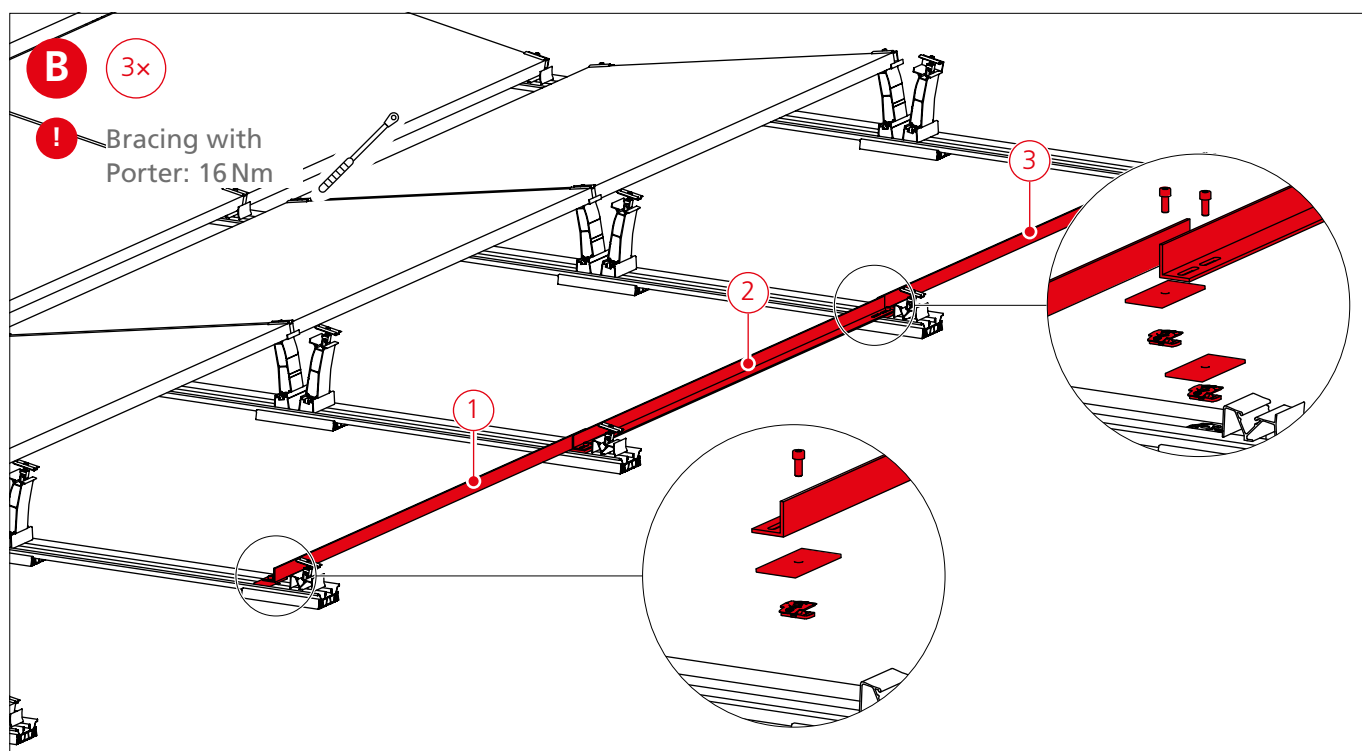
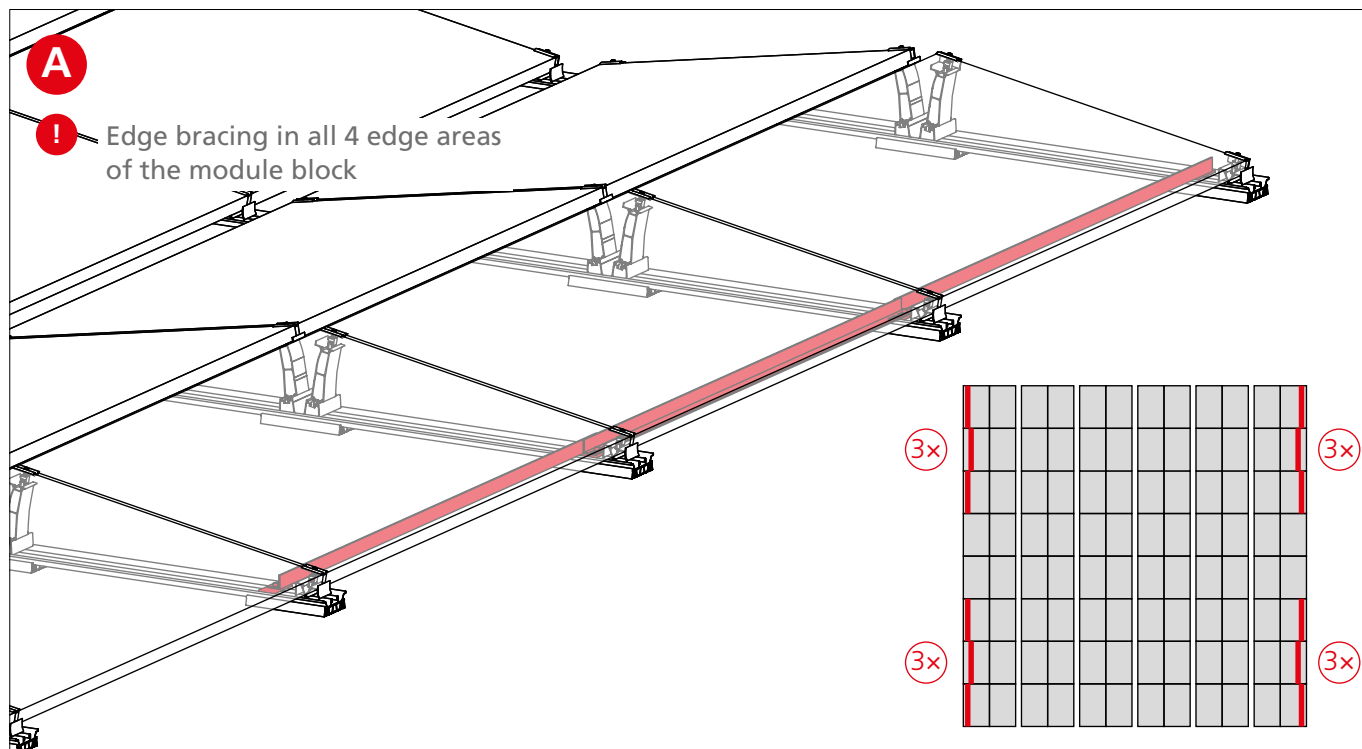

Cable management

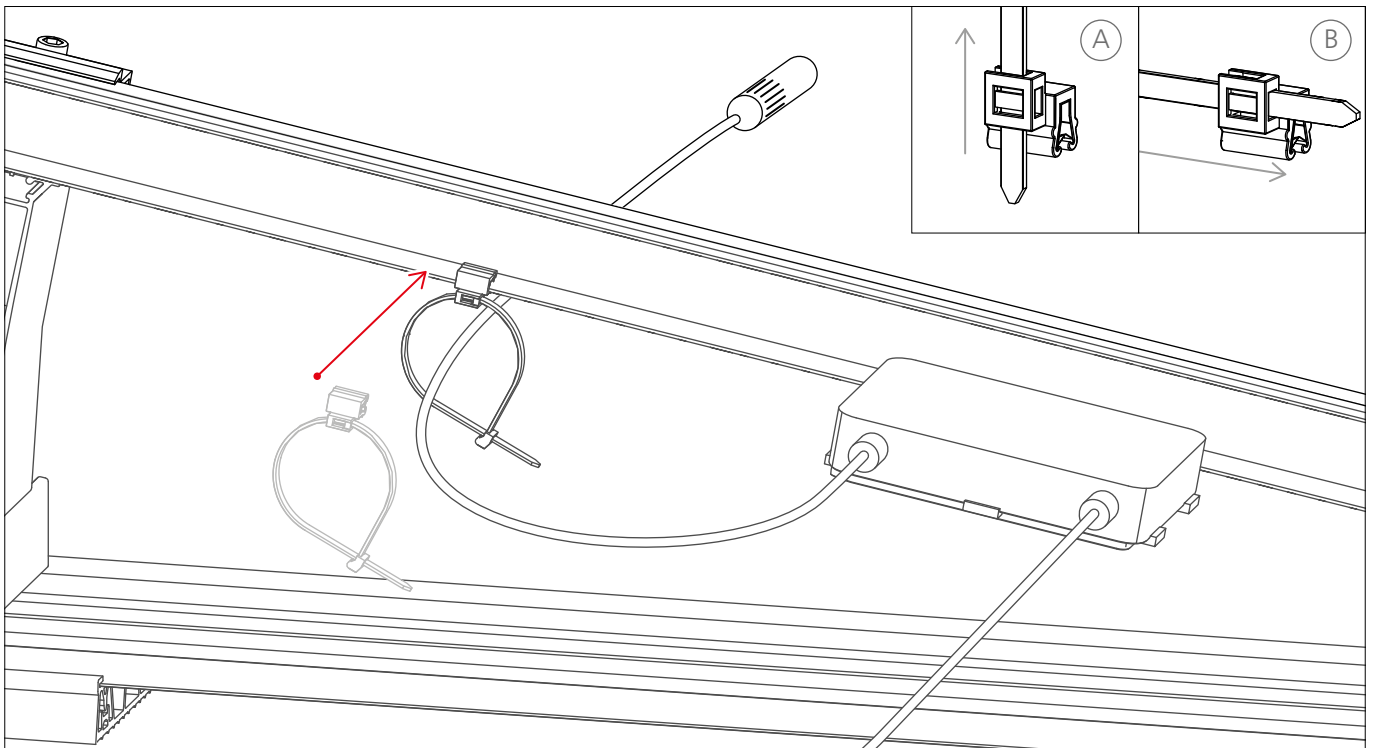

Equipotential bonding with TerraGrif

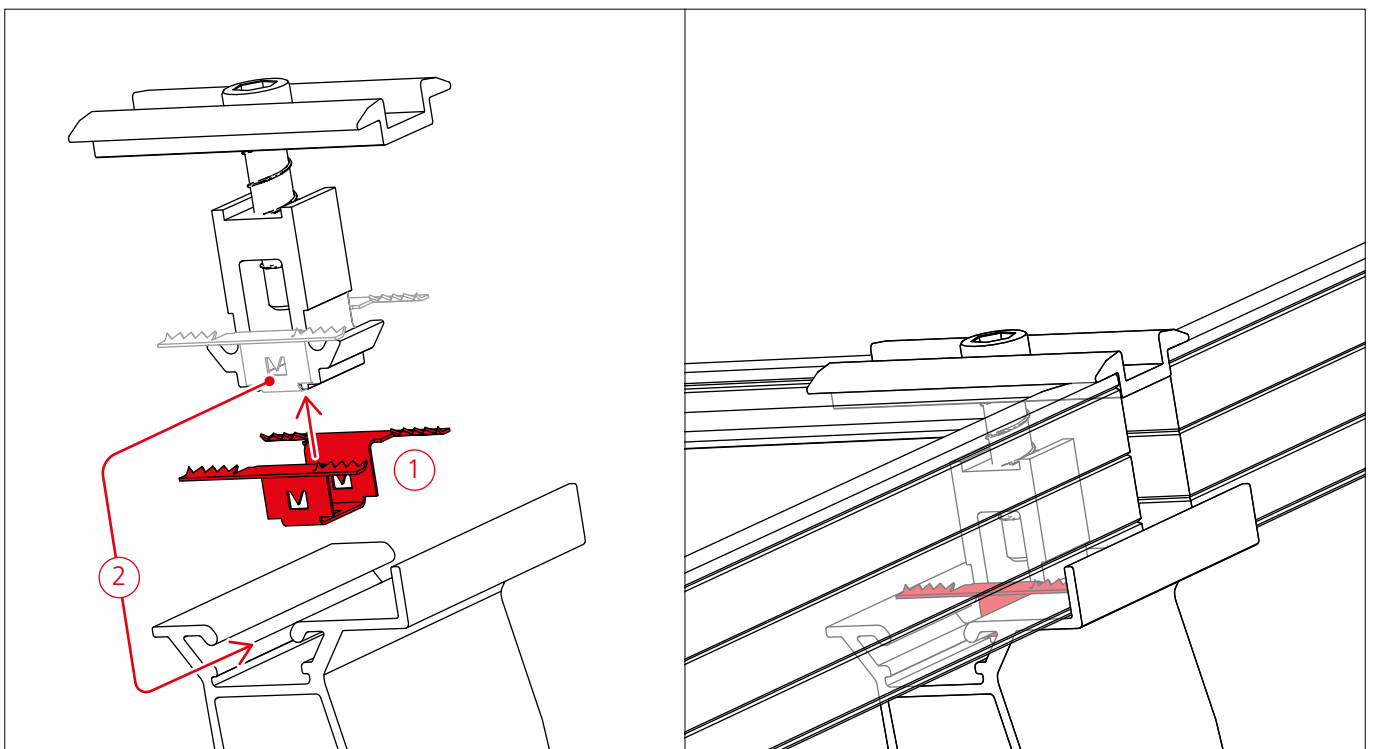

Notes

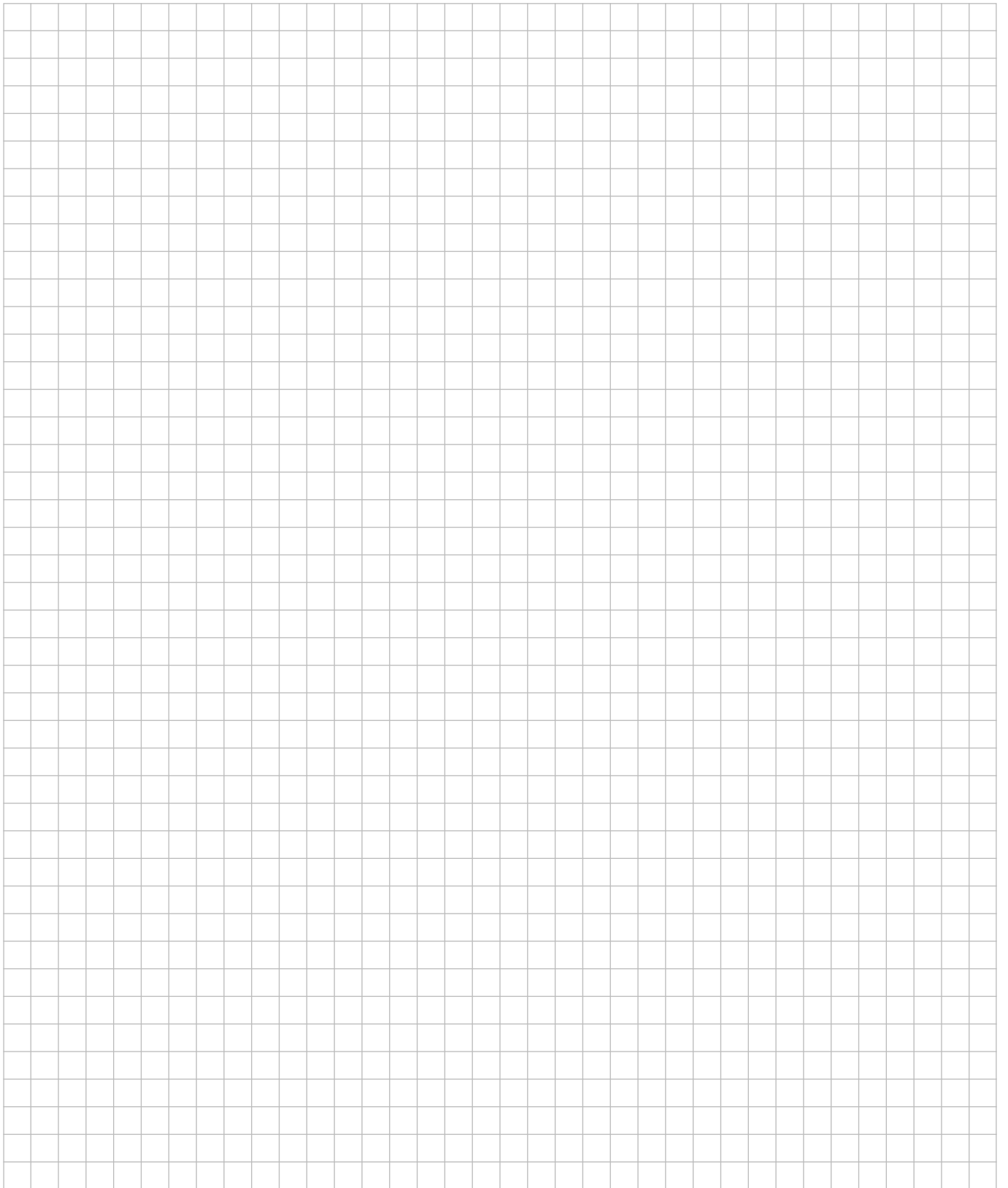

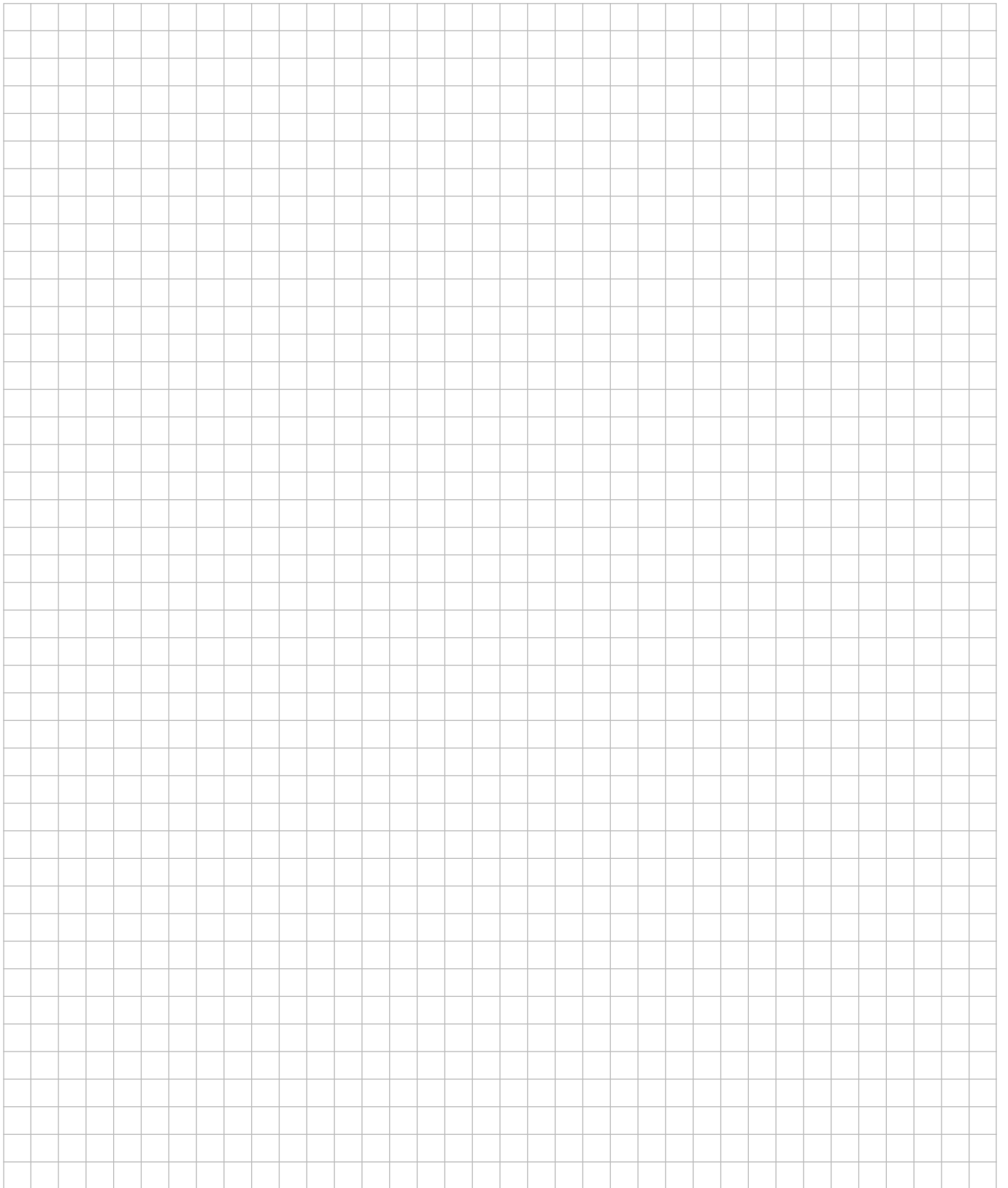

Thank you for choosing a K2 mounting system.

Systems from K2 Systems are quick and easy to install. We hope these instructions have helped. Please contact us with any questions or suggestions for improvement.

Our contact data:

- ▶ www.k2-systems.com/en/contact
- ▶ **Service Hotline: +49 (0)7159 42059-0**

German law shall apply excluding the UN Convention on CISG.
Place of venue is Stuttgart.

Our General Terms of Business apply. Please refer:
www.k2-systems.com

K2 Systems GmbH

Industriestraße 18
71272 Renningen
Germany

+49 (0) 7159 - 42059 - 0
info@k2-systems.com
www.k2-systems.com